

EDITION / VERSİYON
UPDATE / GÜNCELLEME

11/2019
10/2024

58T

WINDOW & DOOR SYSTEM
PENCERE & KAPI SİSTEMİ

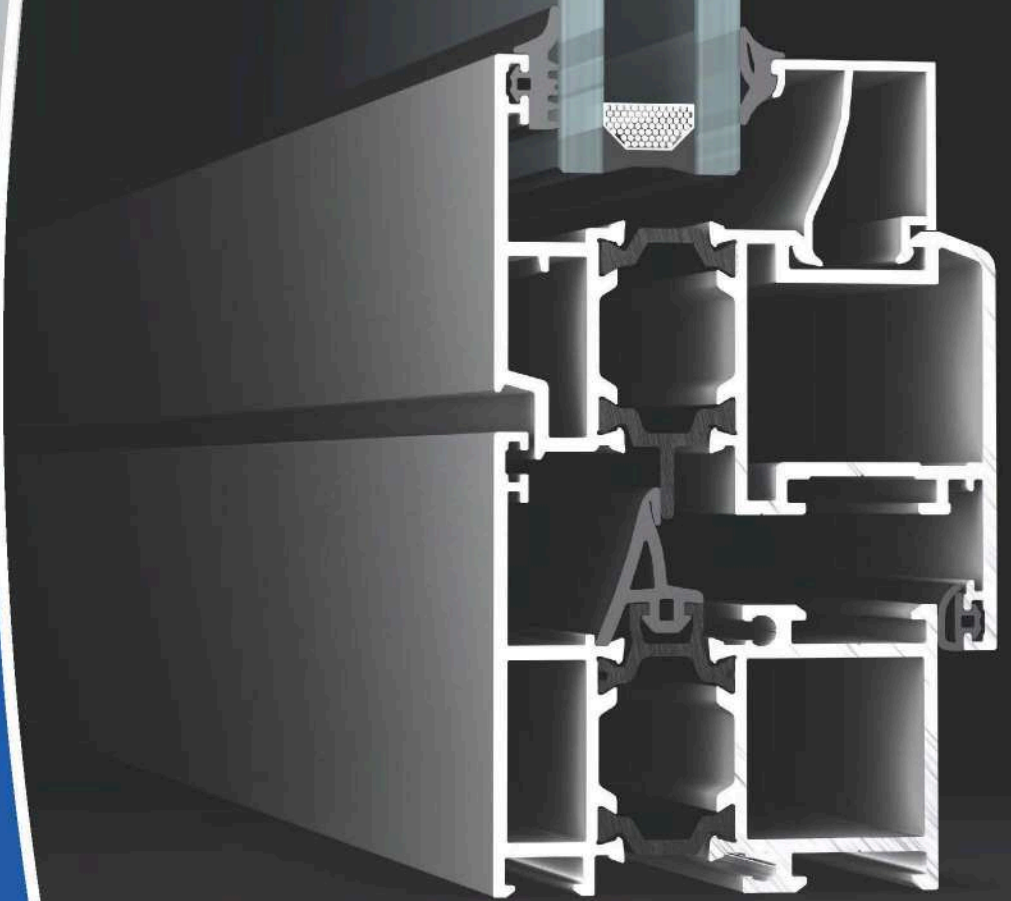

KURTOĞLU®
ALUMINIUM





MODERN HARMONY OF SAFETY AND AESTHETICS

INDEX / İÇİNDEKİLER

Company Information / Hakkımızda	1 - 11
Technical Information / Teknik Bilgiler	13 - 18
Profile Index / Profil İndeks	
Profiles / Profiller	
<i>Profiles (1.8 mm) / Profiller (1.8 mm)</i>	19-38
<i>Profiles (1.5 mm) / Profiller (1.5 mm)</i>	39-45
<i>Profiles (2 mm) / Profiller (2 mm)</i>	47-50
<i>Perimetric Profiles / Perimetrik Profiller</i>	51 - 53
<i>Hidden Sash Profiles / Gizli Kanat Profilleri</i>	55-61
Details / Detaylar	63 - 111
Glazing Tables / Cam Tabloları	113 - 116
Accessories / Aksesuarlar	117 - 128
Cutting Size / Kesim Ölçüleri	129 - 135
Assembly Details / Montaj Detayları	137 - 157



www.kurtoglu.com



'KURTOĞLU ALÜMİNYUM SİSTEMLERİ,
MİMARİ PROJELERİNİZE ESTETİK ÇÖZÜMLER SUNAR.'

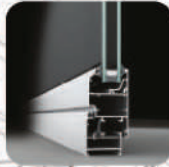



COMPANY INFORMATION

FİRMAMIZ HAKKINDA

Our company started its operations with copper and lead casting in the 1960s, and in 1980, we started to serve in the Aluminium Sector with aluminium extrusion press that has 1200 ton capacity. KURTOĞLU Aluminium is located in Corlu, approximately 100 km away from Istanbul and operates in 31.000 m2 indoor area. With our latest investments, our company has become a modern integrated facility.

- Annual production capacity ~ 34.000 tons,
- Approximately ~ 500 qualified employees,
- ISO 9001:2015 Quality System.
- Qualicoat Seaside Certificate,
- Qualanod Certificate,
- CE Certificate

The main production features of our Company are described as follows:

- Molding Room (Wire Erosion, Treatment Center),
- Aluminium Extrusion Presses, (800 tons, 1460 tons, 1880 tons, 1460/1880 tons, 2100 tons and 2600 tons),
- Anodic Oxidation Facility (75.000 amps - 412.500 m2 / month)
- Electrostatic Powder Paint Facility (750.000 m2 / month)
- Mechanical Processing Section (CNC Treatment Center)

Kurtoğlu Alüminyum exports its products to; U.S. America, New York, Los Angeles, San Francisco, Switzerland, Germany, Austria, Belgium, Sweden, Albania, England, Greece, Bulgaria, Cyprus, Serbia, Montenegro, Hungary, Georgia, Croatia, Turkmenistan, Kyrgyzstan, Azerbaijan, Moldova, Ukraine, Macedonia, Kosovo, Romania, Belarus, Czech Republic, Libya, Iraq, Algeria, Tunisia, Qatar, Nigeria, Israel, Ghana, Gabon, France, India, Saudi Arabia, Burkina Faso, Ethiopia, Egypt, Ivory Coast, Morocco, Poland, The Netherlands, Russia, Madagascar, Niger, Tanzania, Mozambique, Norway, Lebanon, Mayotte, Palestine, Senegal, Somali, Benin, Canada, Panama.

KURTOĞLU ALUMINIUM continues to operate based on the principle of providing services to its customers with zero fault.

Şirketimiz 1960' lı yıllarda Bakır ve Kurşun ile üretim hayatına başlamıştır. 1980 yılında 1200 tonluk Alüminyum Ekstrüzyon presi ile üretim sektörüne girmiştir.

KURTOĞLU Alüminyum; İstanbul'a yaklaşık 100 km mesafede Çorlu'da bulunmaktadır. 31.000 m² kapalı alanda faaliyetini sürdürmektedir. Son yapılan yatırımlarla şirketimiz modern bir entegre tesis haline ulaşmıştır.

- Yıllık kapasite ~ 34.000 ton,
- Yaklaşık ~ 500 kalifiye eleman,
- ISO 9001:2015 kalite sistemi,
- Qualicoat Seaside Belgesi,
- Qualanod Belgesi,
- CE Belgesi,

Şirketimizin ana özellikleri aşağıda da belirtilmiştir:

- Kalıphane Bölümü (Tel erozyon, İşleme Merkezi)
- Alüminyum Ekstrüzyon Presleri; (800 ton, 1460 ton, 1880 ton, 1460/1880 ton, 2100 ton ve 2600 ton),
- Elokso Tesisi (75.000 Amper - 412.500 m² / Ay)
- Elektrostatik Toz Boya Tesisi (750.000 m² / Ay)
- Mekanik İşlem Bölümü (CNC İşleme Merkezi)

KURTOĞLU Alüminyum Ürünleri; Amerika, New York, Los Angeles, San Francisco, İsviçre, Almanya, Avusturya, Belçika, İsveç, Arnavutluk, İngiltere , Yunanistan, Bulgaristan, Kıbrıs, Sırbistan, Karadağ, Macaristan, Gürcistan, Hırvatistan, Türkmenistan, Kırgızistan, Azerbaycan, Moldova, Ukrayna, Makedonya, Kosova, Romanya, Beyaz Rusya, Çek Cumhuriyeti, Libya, Irak, Cezayir, Tunus, Katar, Nijerya, İsrail, Gana, Gabon, Fransa, Hindistan, Suudi Arabistan, Burkina Faso, Etiyopya, Mısır, Fil Dişi Sahili, Fas, Polonya, Hollanda, Rusya Federasyonu, Madagaskar, Nijer, Tanzania, Mozambik, Norveç, Lübnan, Mayotte, Filistin, Senegal, Somali, Benin, Kanada, Panama' ya ihraç edilmektedir.

KURTOĞLU ALÜMİNYUM müşterilerine sıfır hata ile hizmet vermeyi temel alarak çalışmalarını sürdürmektedir.

'The countries of export; İhracat yapılan ülkeler'



Kurtoğlu Aluminium countries of export / İhracat yapılan ülkeler.

- U.S. America / Amerika
- New York
- Los Angeles
- San Francisco
- Switzerland / İsviçre
- Germany / Almanya
- Austria / Avusturya
- Belgium / Belçika
- Sweden / İsveç
- Albania / Arnavutluk
- England / İngiltere
- Greece / Yunanistan
- Bulgaria / Bulgaristan
- Cyprus / Kıbrıs
- Serbia / Sırbistan
- Montenegro / Karadağ
- Hungary / Macaristan
- Georgia / Gürcistan
- Croatia / Hırvatistan
- Turkmenistan / Türkmenistan
- Kyrgyzstan / Kırgızistan
- Azerbaijan / Azerbaycan
- Moldova / Moldova
- Ukraine / Ukrayna
- Macedonia / Makedonya
- Kosova
- Romania / Romanya
- Belarus / Beyaz Rusya
- Czech Republic / Çek Cumhuriyeti
- Libya / Libya
- Iraq / Irak
- Algeria / Cezair
- Tunisia / Tunus
- Qatar / Katar
- Nigeria / Nijerya
- Israel / İsrail
- Ghana / Gana
- Gabon / Gabon
- France / Fransa
- India / Hindistan
- Saudi Arabia / Suudi Arabistan
- Burkina Faso / Burkina Faso
- Ethiopia / Etiyopya
- Egypt / Mısır
- Ivory Coast / Fil Dişi Sahili
- Morocco / Fas
- Poland / Polonya
- The Netherlands / Hollanda
- Russia / Rusya
- Madagascar / Madagaskar
- Niger / Nijer
- Tanzania / Tanzanya
- Mozambique / Mozambik
- Benin
- Palestine / Filistin
- Canada / Kanada
- Lebanon / Lübnan
- Mayotte / Mayotte
- Norway / Norveç
- Panama
- Senegal / Senegal
- Somali



KURTOĞLU
ALUMINIUM





QUALITY POLICY

KALİTE POLİTİKASI

The company's quality policy is based upon the pillars of product quality, state of the art technology, customer satisfaction, training, environmental awareness, and continuous development. Kurtoğlu always implements this policy in all of its operations and units.

Şirketin kalite politikası ürün kalitesine, yeni teknolojilere, müşteri memnuniyetine, eğitime, çevre duyarlılığına ve sürekli gelişime dayanır. Kurtoğlu, her zaman tüm faaliyet ve birimlerinde bu politikayı uygular.

ORGADATA SOFTWARE & SOLUTION PARTNER

The conversational software Ksoft® matches perfectly with the requirements of all aluminum windows, door and curtain wall systems configuration, functionality and menu navigation. Ksoft® is a complete service package for architectural profile applications, and features all you need in the metal-processing operations with tremendous speed and perfection.

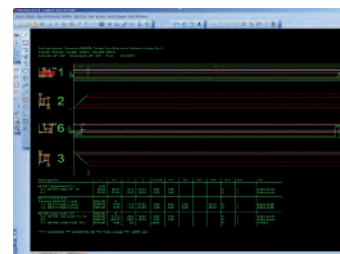
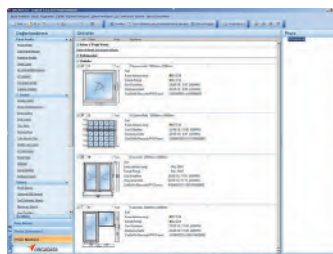
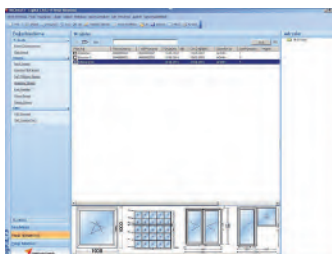
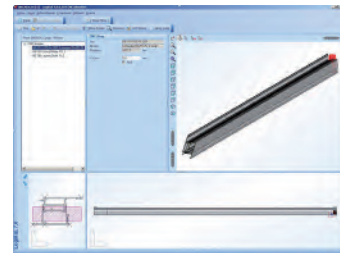
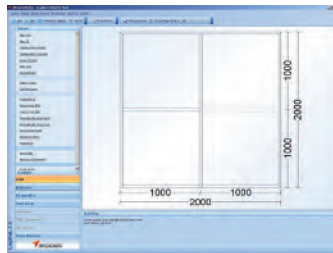
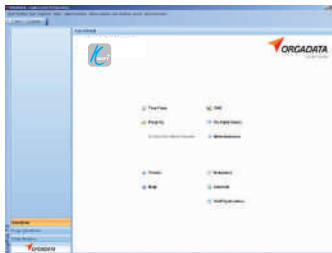

ORGADATA YAZILIM VE ÇÖZÜM ORTAĞI

İletişimli Ksoft® yazılımı tüm alüminyum pencereler, kapı ve cephe sistemleri konfigürasyon, fonksiyonel ve menü navigasyonu ile ilgili ihtiyaçları karşılar. Ksoft® yazılım programı mimari profil uygulaması ve metal işinde gerekli özellikleri optimum hız ve olağanüstü sunan tam bir program paketidir.

58T

TECHNICAL INFORMATION / TEKNİK BİLGİLER

OPENING OPPORTUNITIES / AÇILIM SEÇENEKLERİ

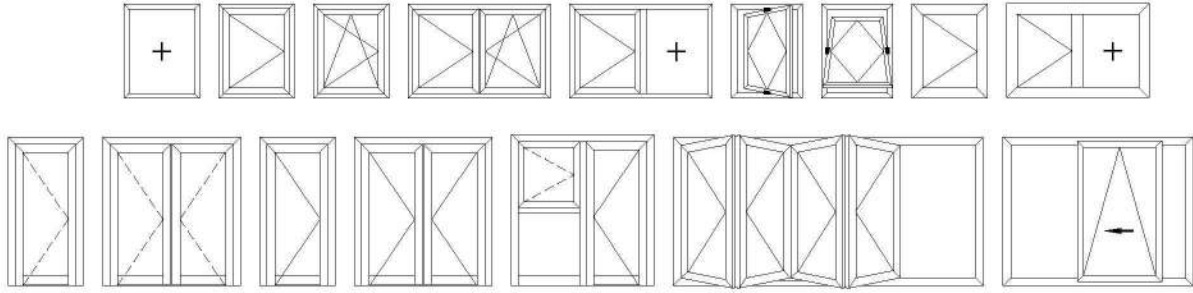

- Fixed / Sabit
- Top Hung / Vasıtas
- Side Hung Window / Tek Açılım
- Tilt & Turn Window / Çift Açılım

- Double Sash / Çift Kanat Açılım
- Angular / Açılı Dönüş
- Inside Opening Door / İçe Açılır Kapı
- Inside Opening Double Sash Door / İçe Açılır Çift Kanat Kapı

- Outside Opening Door / Dışa Açılır Kapı
- Outside Opening Double Sash Door / Dışa Açılır Çift Kanat Kapı
- Pivot Opening / Pivot Açılım
- Tilt & Slide Opening Door / Paralel Sürme
- Folding Door / Katlanır Kapı

58T WINDOW & DOOR SYSTEM

- Various opening options in doors and windows ,
- Use of PVC accessories,
- Safe air and water drainage system,
- Decorative door threshold solutions,
- Providing visual integrity with the systems 58C non thermal,
- 58T, 64T and 74T Thermals and these systems are preferred in the projects due to structural chamfered sash.
- Economic pivot solution by structuring frame and sash with mullion.
- Joint options for mullions with extruded joints and screw methods.
- Constructing doors and windows suitable for 50F facade system.
- Different shapes and with different static values, aesthetic and stable solutions with mullion profiles,
- Hidden sash solution,

58T KAPI & PENCERE SİSTEMİ

- Kapı ve pencerelerde farklı açılım seçenekleri,
- Pvc aksesuar kullanılabilme imkanı,
- Güvenli hava ve su tahliyesi,
- Hemyüz dekoratif kapı eşik çözümleri,
- Pahlı kanat yapısından dolayı tercih edildiği projelerde 58C yalıtımsız sistem,
- 58T, 64T ve 74T yalıtımlı sistemler ile görsel bütünlük sağlaması,
- Orta kayıt profili ile kasa ve kanat oluşturabileceğimiz ekonomik pivot çözümü,
- Orta kayıt profillerini çektirme bağlantı ve vida yoluyla bağlantı seçenekleri,
- 50F Cephe sistemine uygun kapı ve pencere yapma imkanı,
- Farklı statik değerlere sahip ve farklı formlara sahip orta kayıt profilleri ile estetik ve stabil çözümler,
- Gizli kanat çözümü,

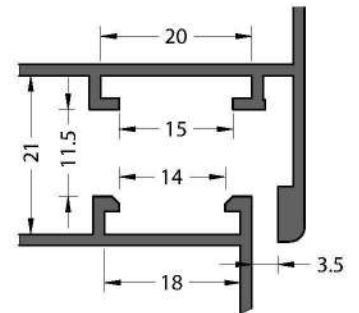
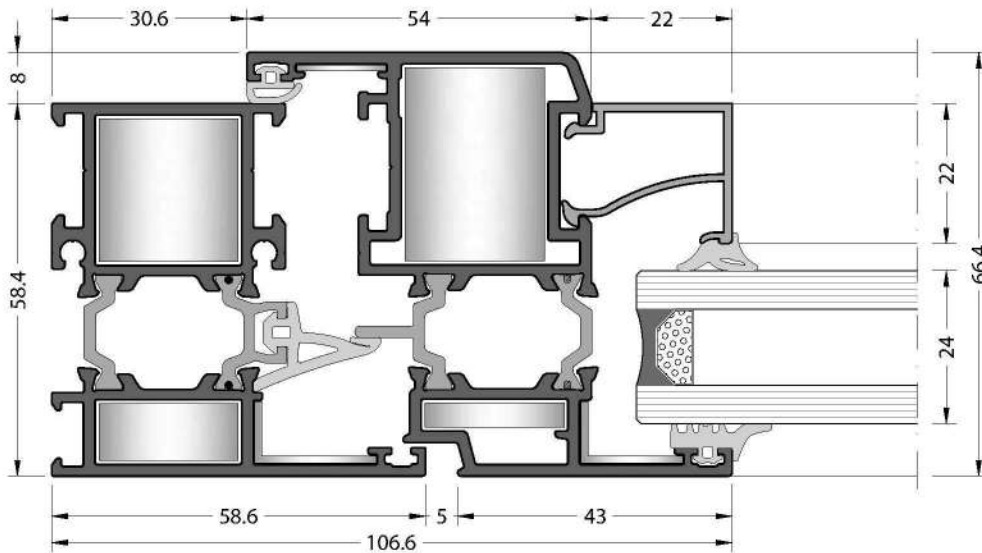

Euro Grove Section 1
Avrupa Kanal 1

systemproperties / sistembilgisi

Construction Depth	*Window : Frame : 58 mm - Vent : 66 mm *Door : Frame : 58 mm - Vent : 66 mm	Derinlik	*Pencere : Kasa : 58 mm - Kanat : 66 mm *Kapı : Kasa : 58 mm - Kanat : 66 mm
Glazing	Glazing from 4 mm up to 37 mm with dry EPDM gaskets. The choice of joints and glazing beads depend on the thickness of the glass. According to the tolerances of the glazing either a smaller or bigger joint and or glazing bead is used.	Cam Kalınlığı	Cam kalınlığı EPDM fitil ile birlikte 4 mm - 37 mm aralığındadır. Bağlantı ve çita cam kalınlığına göre seçilmelidir. Cam toleransına göre küçük yada büyük bağlantı veya cam çitası kullanılır.
Insulation Bar Thermal Permability	18 mm (Uf) 2,96 W / m2K	Isı Bariyeri Isı Geçirgenliği	18 mm (Uf) 2,96 W / m2K
Opening Opportunities	<ul style="list-style-type: none"> • Fixed • Top Hung • Side Hung Window • Tilt & Turn Window • Double Sash • Angular • Inside Opening Door • Inside Opening Double Sash Door • Outside Opening Door • Outside Opening Double Sash Door • Pivot Opening • Tilt & Slide Opening Door • Folding Door • Hidden Sash 	Açılım Seçenekleri	<ul style="list-style-type: none"> • Sabit • Vasistas • Tek Açılım • Çift Açılım • Çift Kanat Açılım • Açılı Dönüş • İçe Açılır Kapı • İçe Açılır Çift Kanat Kapı • Dışa Açılır Kapı • Dışa Açılır Çift Kanat Kapı • Pivot Açılım • Paralel Sürme • Katlanır Kapı • Gizli Kanat
Connections	Press corner joints can apply for fixing corners. The transoms are fixed with screw and junction.	Bağlantılar	Köşeyi birleştirmek için pres köşe bağlantıları uygulanabilir. Orta kayıtlar vida kullanılarak yada çekirtme bağlantılar ile montaj yapılabilir.
Gaskets	The opening windows have a central gasket an acoustical gasket and glazing gaskets in EPDM The central gasket ensures the window is wind and watertight over the complete surface. The acoustic gasket is uninterrupted.	Fitil	Açılır pencerede EPDM olan akustik orta fitil ve cam fitili kullanılır. Orta fitil tüm yüzey üzerinde hava ve su geçirmezliği, akustik fitil ise süreklilik sağlar.
Drainage	All window types must be equipped with a drainage system.	Su Tahliye	Tüm pencere sistemleri su tahliye donanımına sahip olmalıdır.

productionproperties / üretimbilgisi

The aluminium profiles have been extruded from the alloy EN-AW 6063 according to the EN-AW 6060.		Alüminyum profiller EN-AW 6063 alaşımından ve EN-AW 6060 standardına göre üretilir.	
Alloy	Physical Properties	Fiziksel Özellikler	
	1. Density : 2.70 Kg / dm3	1. Yoğunluk : 2.70 Kg / dm3	
	2. Modules of Elasticity : 69 kN / mm2	2. Elastisite Modülü : 69 kN / mm2	
	3. Resistivity : 20° 33 n Ω .m	3. Direnç : 20° 33 n Ω .m	
	4. Melting point : 600 - 655 °C	4. Erime Noktası : 600 - 655 °C	
	5. Linear expeansion coefficient : 20 - 100°C μ °C ⁻¹	5. Genişleme Katsayısı : 20 - 100°C μ °C ⁻¹	
Surface Treatment	Mechanical Properties	Mekanik Özellikler	
	1. Tensile strength : Min 215 MPa	1. Kopma Dayanıklılığı : Min 215 MPa	
	2. Yield strength : 190 MPa	2. Elastisite Limiti : 190 MPa	
	3. Elongation : % 10	3. Uzama : % 10	
	4. Hardness : 67 Brinell	4. Sertlik : 67 Brinell	
	Anodising	Eloksal	
	In anodising process , microns of the profiles for the inside and outside use are different. The complete anodisation process takes place in accordance with the specifications of QUALANOD .	Eloksal projesinde profil mikronları iç ve dış kullanım için farklıdır. Bütün eloksal projesi QUALANOD spesifikasyonlarına göre uygulanır.	
	Electrostatic Powder Coating	Yüzey İşlem	
	The thermal break allows the profile to be painted when compounded. On average, the coating thickness is minimally 60 micron. The complete powder coating process takes place in accordance with the specifications of QUALICOAT .	Elektrostatik Toz Boya Isı bariyeri çakıldığında profil boyanabilir. Genel olarak kaplama kalınlığı minimum 60 mikrondur. Bütün toz boya projesi QUALICOAT spesifikasyonlarına göre uygulanır.	

Evidence of Performance

Air permeability, Watertightness, Resistance to wind load



Test Report

No. 12-001312-PR01
(PB-A01-02-en-01)

Client KURTOGLU ALUMINYUM
BAKIR KURSUN SAN. A.S.
Haciseremet Mevkii TEM
Corlu Cikisi Velimese
59860 Tekirdag
Turkey

Product Tilt and turn window with fixed sublight

Designation System designation: 58T

Performance-relevant product details Material: Aluminium profiles with thermal break

Overall dimensions (W x H) 792 mm x 2,000 mm

Special features

Basis

EN 14351-1:2006+A1:2010

Test standard/s:

EN 1026:2000-06
EN 1027:2000-06
EN 12046-1:2003-11
EN 12211:2000-06
EN 14609:2004-06
Correspond/s to the national standard/s (e.g. DIN EN)

Representation

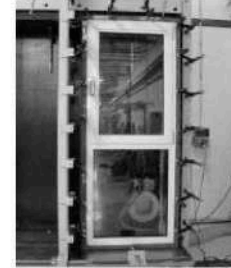

Results

Air permeability according to EN 12207:1999-11



Class 4

Watertightness according to EN 12208:1999-11



Class E1500

Resistance to wind load
according to EN 12210:1999-11/AC:2002-08



Class C4 / B4

ift Rosenheim

26.09.2012

Robert Kolacny, Dipl.-Ing. (FH)
Deputy Head of Testing Department
Building Components

Rolf Schnitzler, Dipl.-Ing. (FH)
Operating Product Officer
Building Components

Instructions for use

The results obtained can be used by the manufacturer as the basis for the manufacturer ITT test report summary. Observe the specifications set out by the applicable product standard.

Validity

The data and results refer solely to the tested and described specimen. Classification remains valid as long as the product and the above basis remain unchanged. The results can be extrapolated under the manufacturer's own liability subject to observance of the relevant specifications set out by the applicable product standard. This test/evaluation does not allow any statement to be made on any further characteristics regarding performance and quality of the construction presented; in particular the effects of weathering and ageing were not taken into account.

Notes on publication

The ift-Guidance Sheet "Advertising with ift test documents" applies. The cover sheet can be used as an abstract.

The report contains a total of 17 pages.



ift Rosenheim GmbH
Geschäftsführer:
Dipl.-Ing. (FH) Ulrich Sieberath
Dr. Jochen Peicht

Theodor-Gießl-Str. 7 - 9
D-83026 Rosenheim
Tel. +49 (0)8031/261-0
Fax +49 (0)8031/261-290
www.ift-rosenheim.de

Sitz: 83026 Rosenheim
AG Traunstein, HRB 14783
Sparkasse Rosenheim
Kto. 3622
BLZ 711 500 00

Notified Body Nr.: 0757
Anerkannte PUZ-Stelle: BAY 18
 DIN CERTIFIED
DIN EN ISO 9001
DIN EN ISO 14001
DIN EN ISO 19011
DIN EN ISO 45001

THERMAL ISOLATION / ISI GEÇİRGENLİK

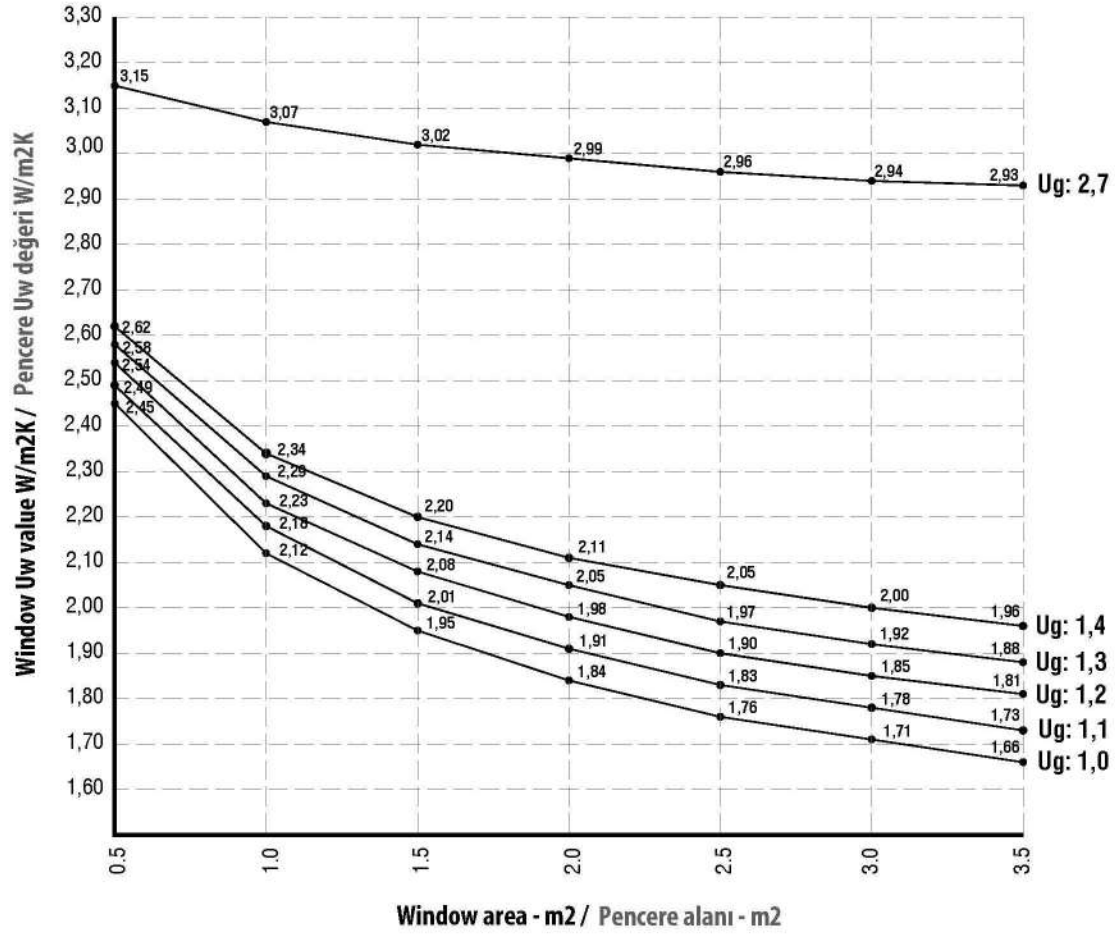

The graphic shows the Uw value of the window system 58T.
 The values are applied for six different glasses (Ug 1.0 - 2.7 W/m²K) and areas (m²).
 Bu grafik, 58T sistemine ait pencere Uw değerlerini göstermektedir.
 Değerler 6 farklı cam (Ug 1.0 - 2.7 W/m²K) ve alanlar (m²) için uygulanmıştır.

THERMAL PERFORMANCE / ISI PERFORMANSI

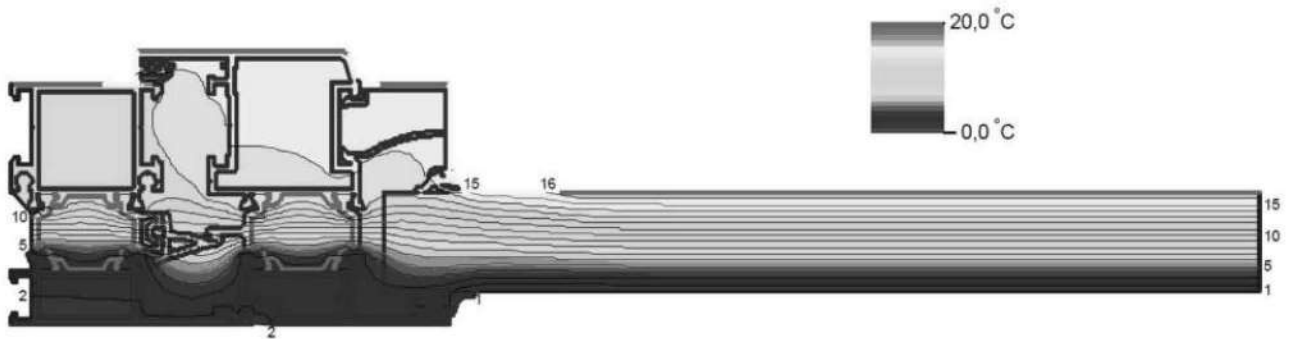

System section Uf value / Sistem kesit Uf değeri

Uf : 2,96 W/m²K

STATIC VALUES / STATİK DEĞERLER

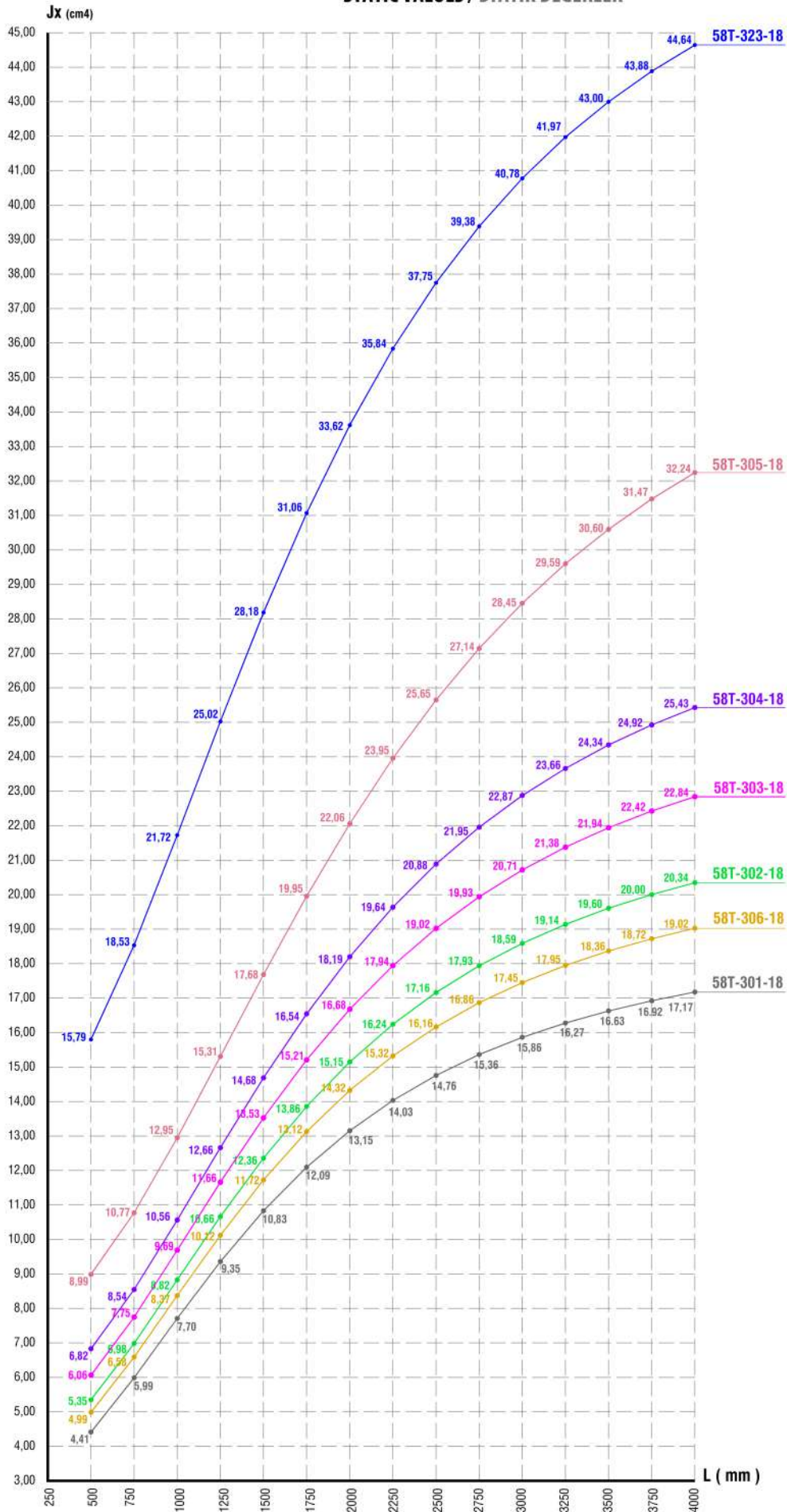

Jy Values / Jy Değerleri

Profile / Profil

Jy(cm4)

58T-301-18	8,03	58T-302-18	15,29
58T-306-18	11,77	58T-303-18	24,06
58T-304-18	36,67	58T-305-18	92,77
58T-323-18	18,88		

STATIC VALUES / STATİK DEĞERLER

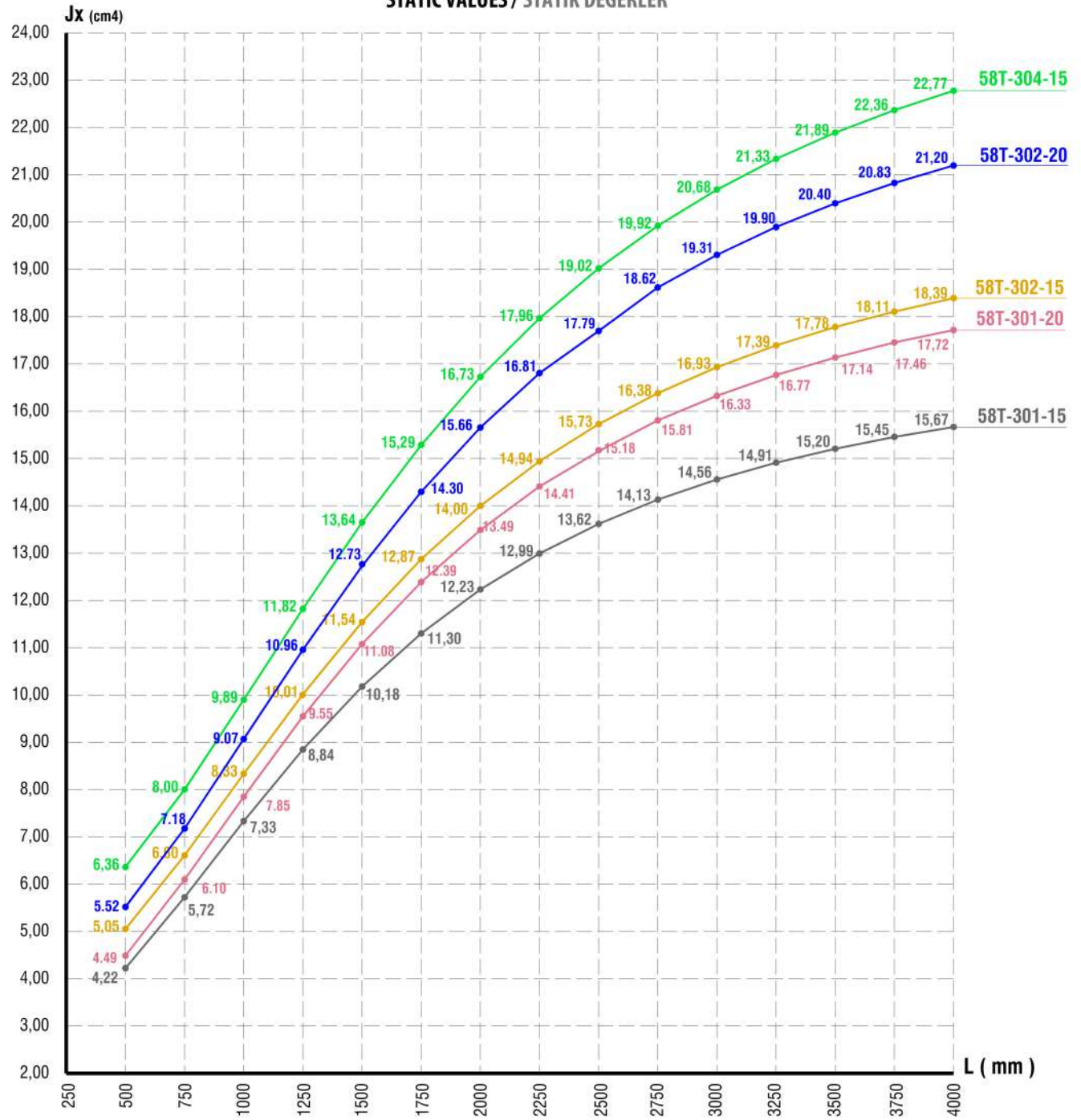

Jy Values / Jy Değerleri

Profile / Profil	58T-301-15	58T-302-15	58T-304-15	58T-301-20	58T-302-20
Jy(cm4)	7,52	14,19	33,68	8,25	15,71

STATIC VALUES / STATİK DEĞERLER

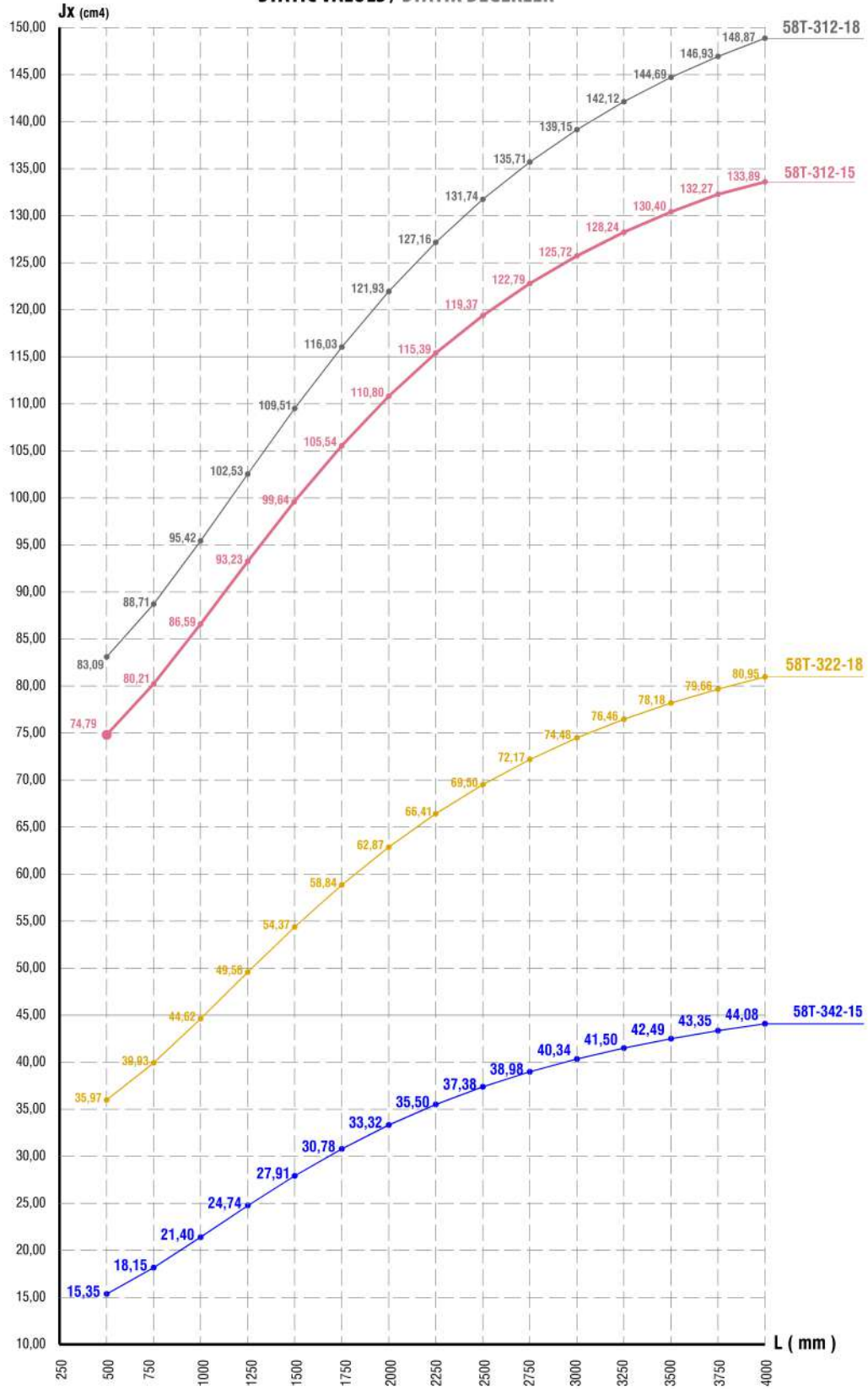

Jy Values / Jy Değerleri

Profile / Profil	58T-312-18	58T-322-18	58T-312-15	58T-342-15
Jy(cm ⁴)	27,34	27,09	24,40	20,65

STATIC VALUES / STATİK DEĞERLER

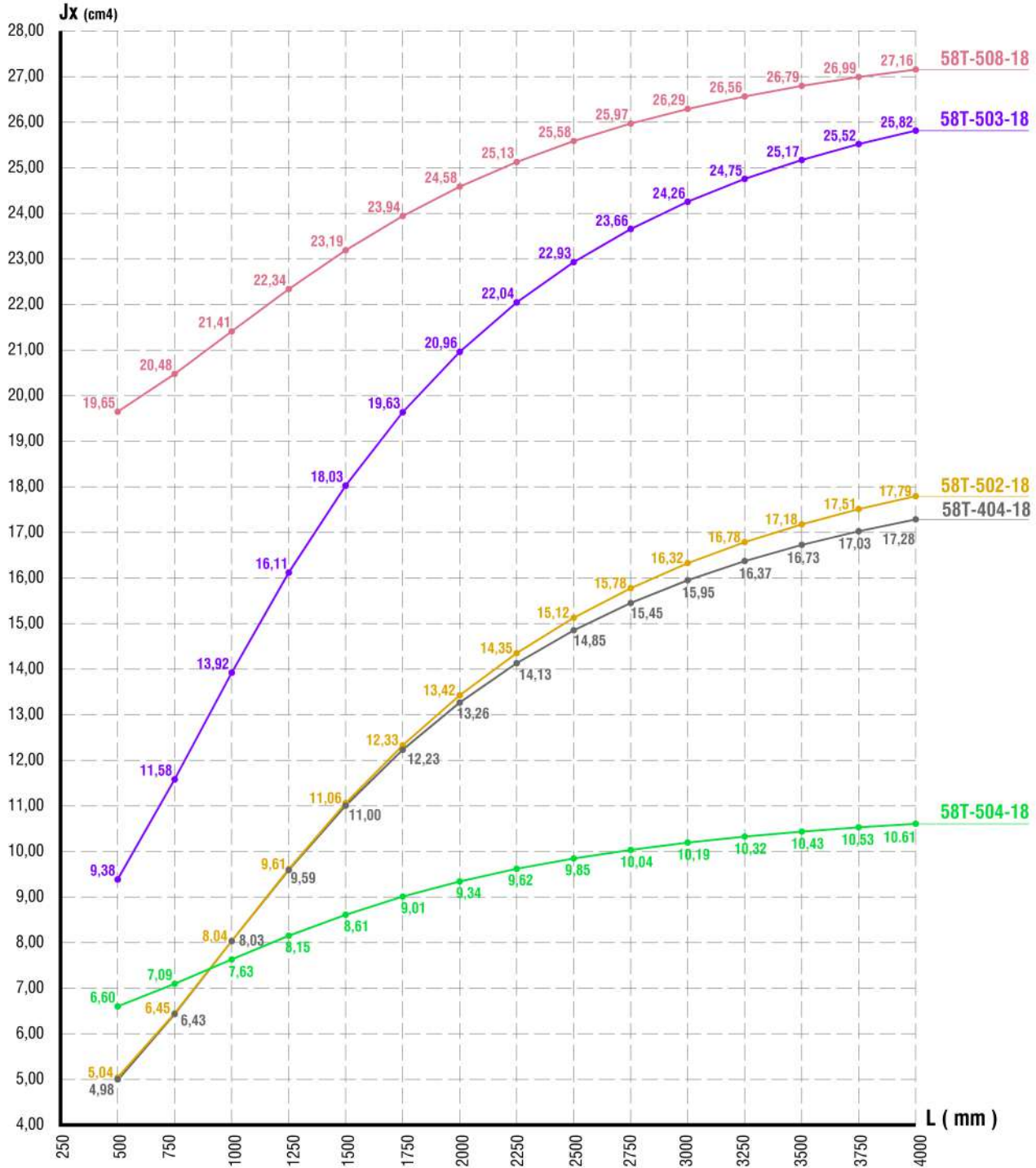

Jy Values / Jy Değerleri









Profile / Profil	58T-404-18	58T-502-18	58T-503-18	58T-504-18 *	58T-508-18
Jy(cm ⁴)	7,68	11,01	10,41	11,30	28,57

* The static value is according to 45° / Statik değer 45° göre alınmıştır.

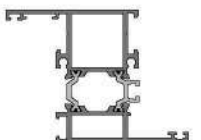
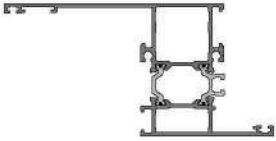

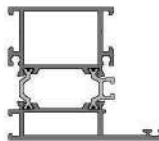

58T

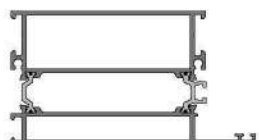
PROFILE INDEX / PROFİL İNDEKS





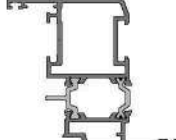
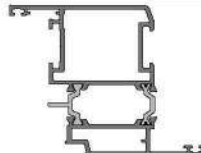
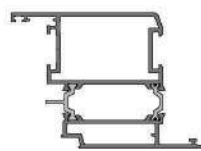
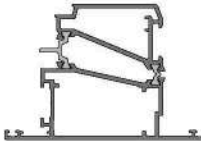
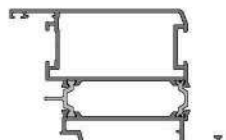
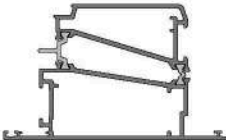

PROFILES / PROFİLLER

CODE KOD	DRAWING ÇİZİM	WEIGHT AĞIRLIK Kg/m
58T-102-18		1.471
58T-102-15		1.352
58T-112-15		1.557
58T-122-18		1.608
58T-132-15		1.661
58T-142-15		1.565
58T-103-18		1.663
58T-113-18		1.892
58T-133-18		1.957
58T-104-18		1.860
58T-105-18		2.441

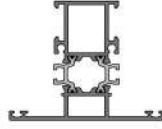
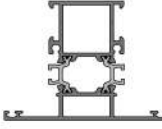

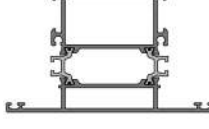



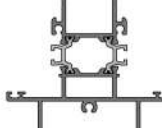

PROFILES / PROFİLLER

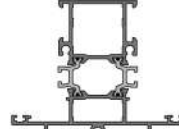
CODE KOD	DRAWING ÇİZİM	WEIGHT AĞIRLIK Kg/m
58T-123-18		1.530
58T-201-18		1.420
58T-201-15		1.285
58T-201-20		1.461
58T-202-18		1.657
58T-202-15		1.477
58T-202-20		1.722
58T-203-18		1.850
58T-204-18		2.037
58T-204-15		1.806
58T-204-20		2.138
58T-205-18		2.235
58T-205-15		1.963
58T-205-20		2.308
58T-206-18		2.311
58T-206-20		2.388
58T-207-18		2.495
58T-207-20		2.581
58T-215-18		2.103
58T-301-18		1.360
58T-301-15		1.262
58T-301-20		1.394

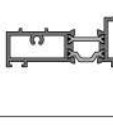

PROFILES / PROFİLLER

CODE KOD	DRAWING ÇİZİM	WEIGHT AĞIRLIK Kg/m
58T-306-18		1.510
58T-302-18		1.604
58T-302-15		1.470
58T-302-20		1.662
58T-303-18		1.791
58T-304-18		1.992
58T-304-15		1.800
58T-305-18		2.574
58T-312-18		2.650
58T-312-15		2.360
58T-322-18		2.438
58T-323-18		2.036





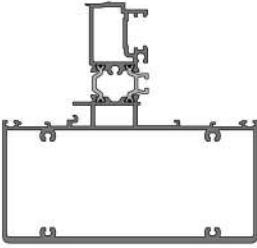
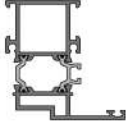
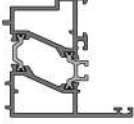
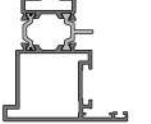
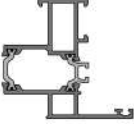

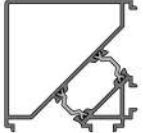





PROFILES / PROFİLLER

CODE KOD	DRAWING ÇİZİM	WEIGHT AĞIRLIK Kg/m
58T-342-15		2.017
58T-402-18		2.886
58T-412-00		6.044
58T-403-18		1.079
20-162-00		1.269
60T-406-00		0.932
58T-405-00		0.374
20-101-00		0.354
07-211-00		0.183

PROFILES / PROFİLLER

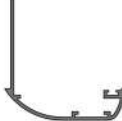
CODE KOD	DRAWING ÇİZİM	WEIGHT AĞIRLIK Kg/m
58T-501-18		1.484
58T-545-18		1.511
58T-404-18		1.439
58T-502-18		1.583
58T-503-18		1.461
58T-507-18		1.363
58T-509-25		2.304
18-351-00		1.124
58T-508-18		1.720





PROFILES / PROFİLLER

CODE KOD	DRAWING ÇİZİM	WEIGHT AĞIRLIK Kg/m
58T-504-18		1.332
58T-518-18		1.532
07-112-00		0.148
58T-511-00		0.183
07-111-00		0.233
07-506-013		0.186
07-510-013		0.201
07-512-013		0.210
07-102-00		0.324
07-103-00		0.488
07-105-00		0.875
07-131-011		0.568
07-131-012		0.618







PROFILES / PROFİLLER

CODE KOD	DRAWING ÇİZİM	WEIGHT AĞIRLIK Kg/m
07-131-018		0.902
07-133-011		1.064
07-132-011		0.802
08-103-00		0.237
08-104-00		0.256
08-105-00		0.260
08-107-00		0.262
08-108-00		0.269
08-109-00		0.280
08-110-00		0.266



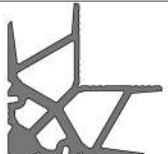
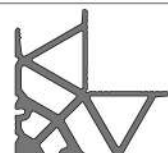
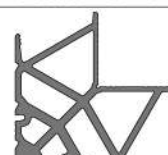

PROFILES / PROFİLLER

CODE KOD	DRAWING ÇİZİM	WEIGHT AĞIRLIK Kg/m
08-111-00		0.216
08-112-00		0.291
08-113-00		0.300
08-114-00		0.306
08-115-00		0.317
08-116-00		0.331
08-117-00		0.309
08-120-00		0.345
08-121-00		0.349
09-121-00		2.395

PROFILES / PROFİLLER

CODE KOD	DRAWING ÇİZİM	WEIGHT AĞIRLIK Kg/m
09-101-00		2.561
09-110-00		3.501
09-122-00		3.294
09-103-00		3.689
09-123-00		4.369
09-124-00		4.572
09-105-00		5.453
09-117-00		7.012
09-113-00		7.241



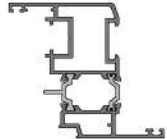
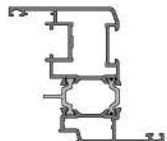
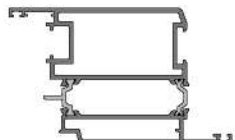
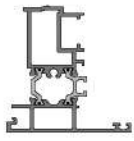

PROFILES / PROFİLLER

CODE KOD	DRAWING ÇİZİM	WEIGHT AĞIRLIK Kg/m
09-114-00		8.744
09-901-00		0.582
09-902-00		0.552
09-903-00		0.856

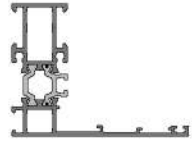

PERIMETRIC PROFILES / PERİMETRİK PROFİLLER

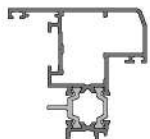
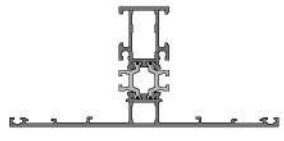
CODE KOD	DRAWING ÇİZİM	WEIGHT AĞIRLIK Kg/m
58T-252-18		1.713
58T-252-15		1.515
58T-256-18		2.548
58T-551-18		1.509

HIDDEN SASH PROFILES / GİZLİ KANAT PROFİLLERİ

CODE KOD	DRAWING ÇİZİM	WEIGHT AĞIRLIK Kg/m
58T-131-15		1.333
58T-141-15		1.533
58T-231-15		1.283
58T-331-15		1.636
58T-332-15		1.843

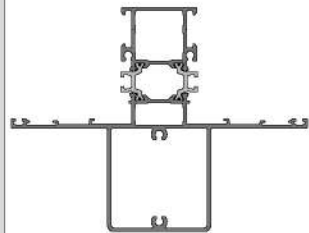
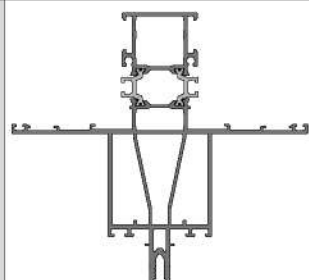
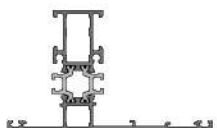
HIDDEN SASH PROFILES / GİZLİ KANAT PROFİLLERİ

CODE KOD	DRAWING ÇİZİM	WEIGHT AĞIRLIK Kg/m
58T-333-15		2.677
58T-334-15		3.430
58T-335-15		1.450
58T-531-15		1.044
58T-831-00		0.129

58T

PROFILES / PROFİLLER
1.8 mm

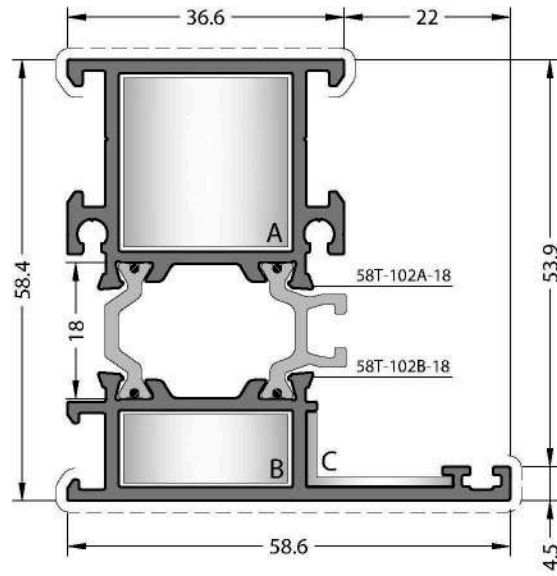

CODE / KOD

58T-102-18

THEORETICAL WEIGHT kg/m

TEORİK AĞIRLIK kg/m

1.471

CORNER JOINTS

KÖŞE BAĞLANTILAR



A CC-103-23.0



B CC-103-09.6



C EM58-21

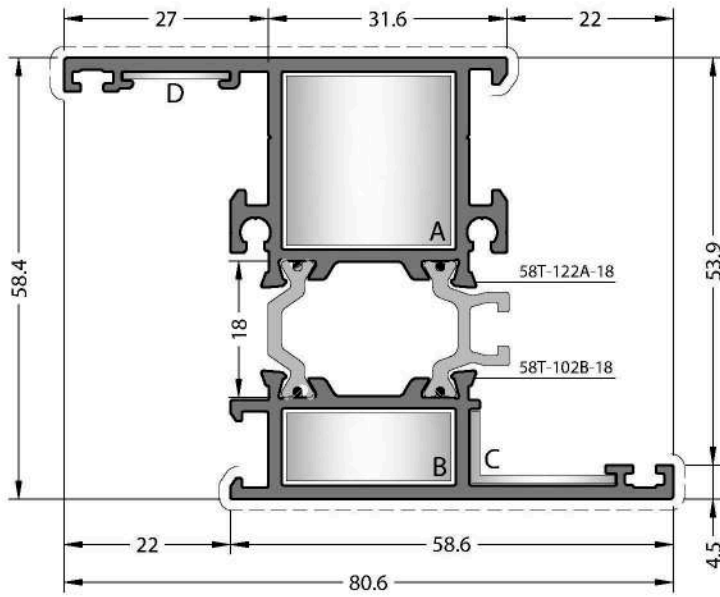

CODE / KOD

58T-122-18

THEORETICAL WEIGHT kg/m

TEORİK AĞIRLIK kg/m

1.608

CORNER JOINTS

KÖŞE BAĞLANTILAR



A CC-103-23.0



B CC-103-09.6



C EM58-21



D MK-20.1

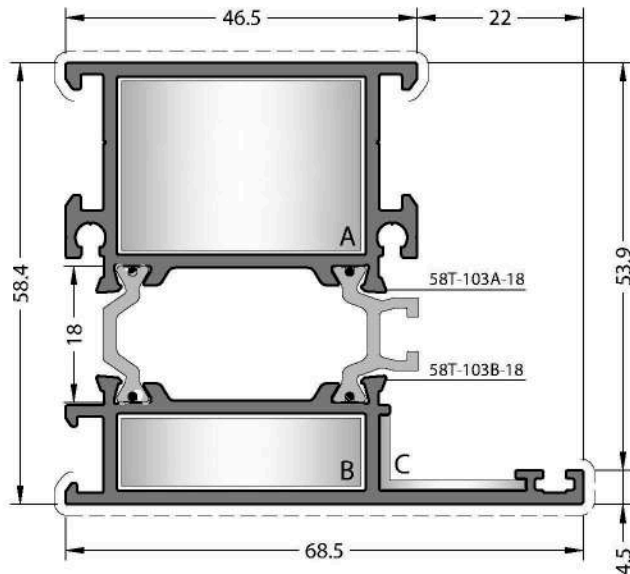

CODE / KOD

58T-103-18

THEORETICAL WEIGHT kg/m

TEORİK AĞIRLIK kg/m

1.663

CORNER JOINTS

KÖŞE BAĞLANTILAR



A CC-124-23.0



B CC-124-09.6





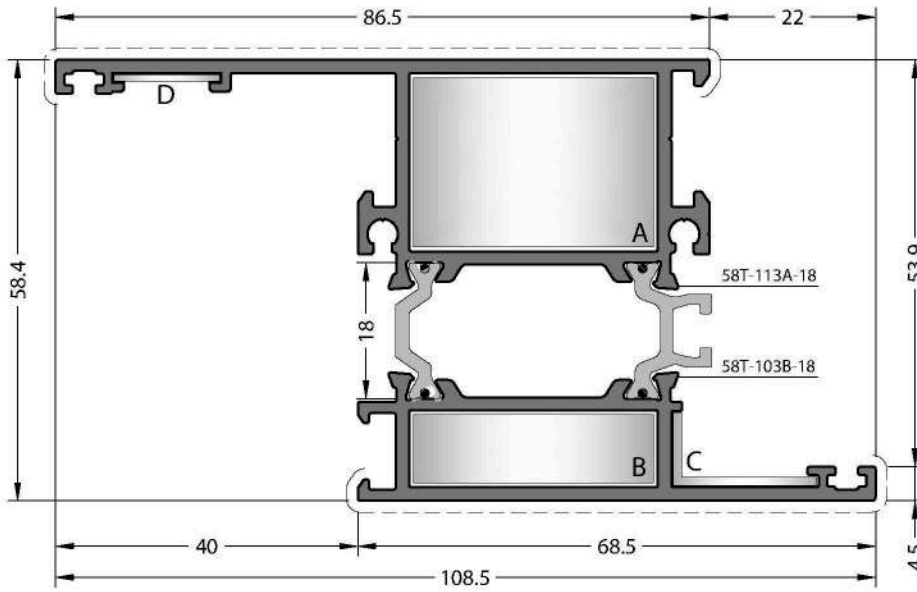

C EM58-21



CODE / KOD
58T-113-18

THEORETICAL WEIGHT kg/m
TEORİK AĞIRLIK kg/m
1.892

CORNER JOINTS
KÖŞE BAĞLANTILAR



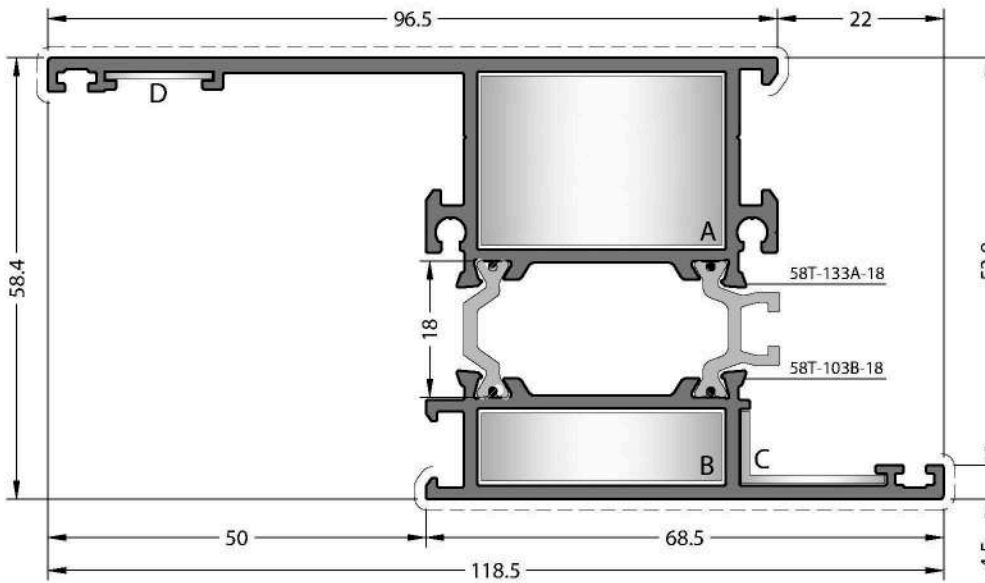

-  **A** CC-124-23.0
-  **B** CC-124-09.6
-  **C** EM58-21
-  **D** MK-20.1



CODE / KOD
58T-133-18

THEORETICAL WEIGHT kg/m
TEORİK AĞIRLIK kg/m
1.957

CORNER JOINTS
KÖŞE BAĞLANTILAR

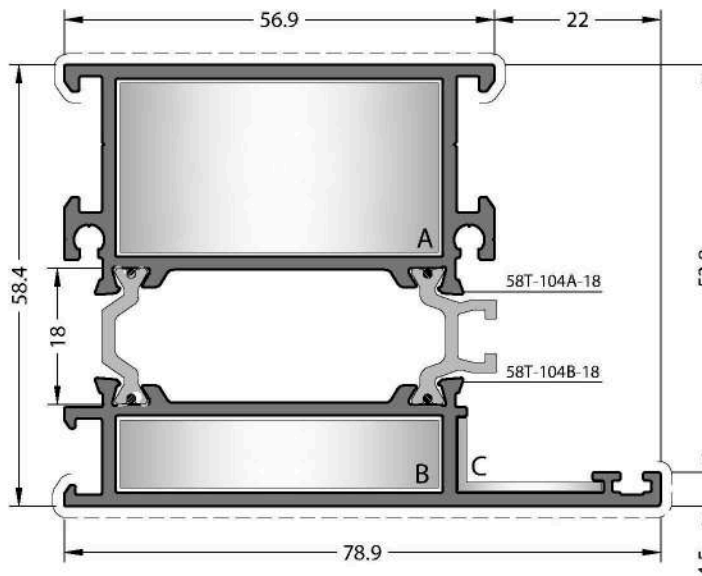

-  **A** CC-124-23.0
-  **B** CC-124-09.6
-  **C** EM58-21
-  **D** MK-20.1



CODE / KOD
58T-104-18

THEORETICAL WEIGHT kg/m
TEORİK AĞIRLIK kg/m
1.860

CORNER JOINTS
KÖŞE BAĞLANTILAR

-  **A** CC-105-23.0
-  **B** CC-105-09.6
-  **C** EM58-21

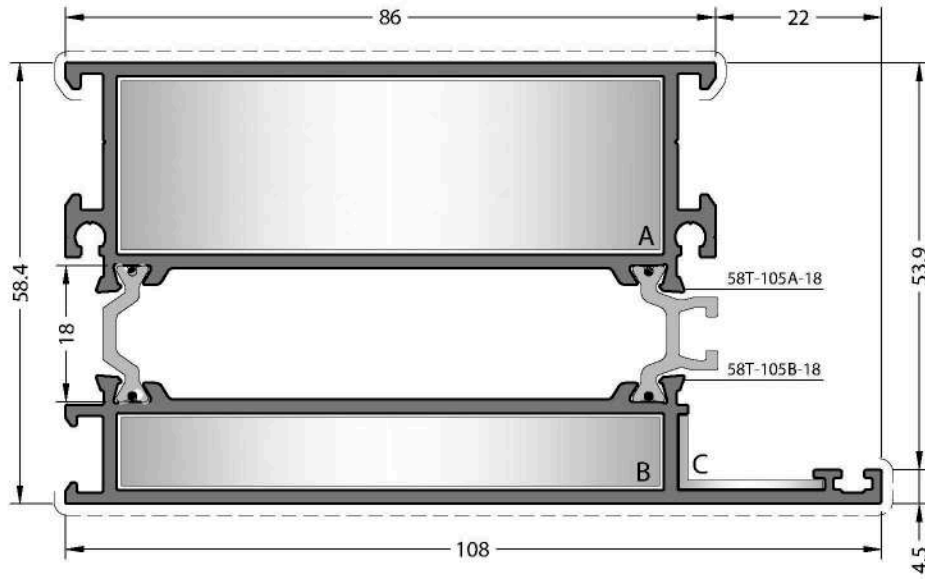

CODE / KOD
58T-105-18

THEORETICAL WEIGHT kg/m
TEORİK AĞIRLIK kg/m
2.441

CORNER JOINTS
KÖŞE BAĞLANTILAR



A CC-114-23.0



B CC-114-09.6



C EM58-21

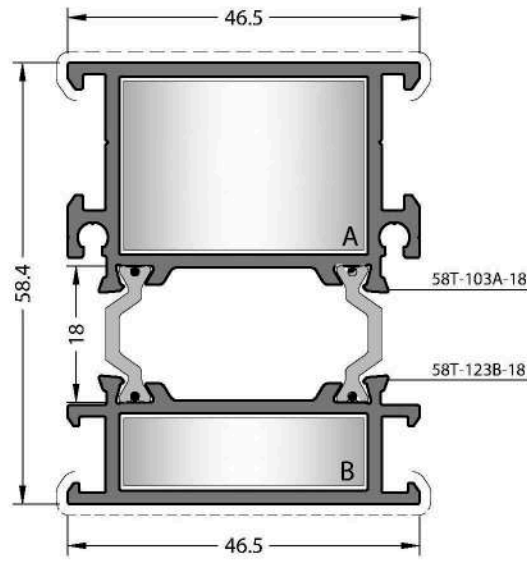

CODE / KOD
58T-123-18

THEORETICAL WEIGHT kg/m
TEORİK AĞIRLIK kg/m
1.530

CORNER JOINTS
KÖŞE BAĞLANTILAR



A CC-124-23.0



B CC-124-09.6

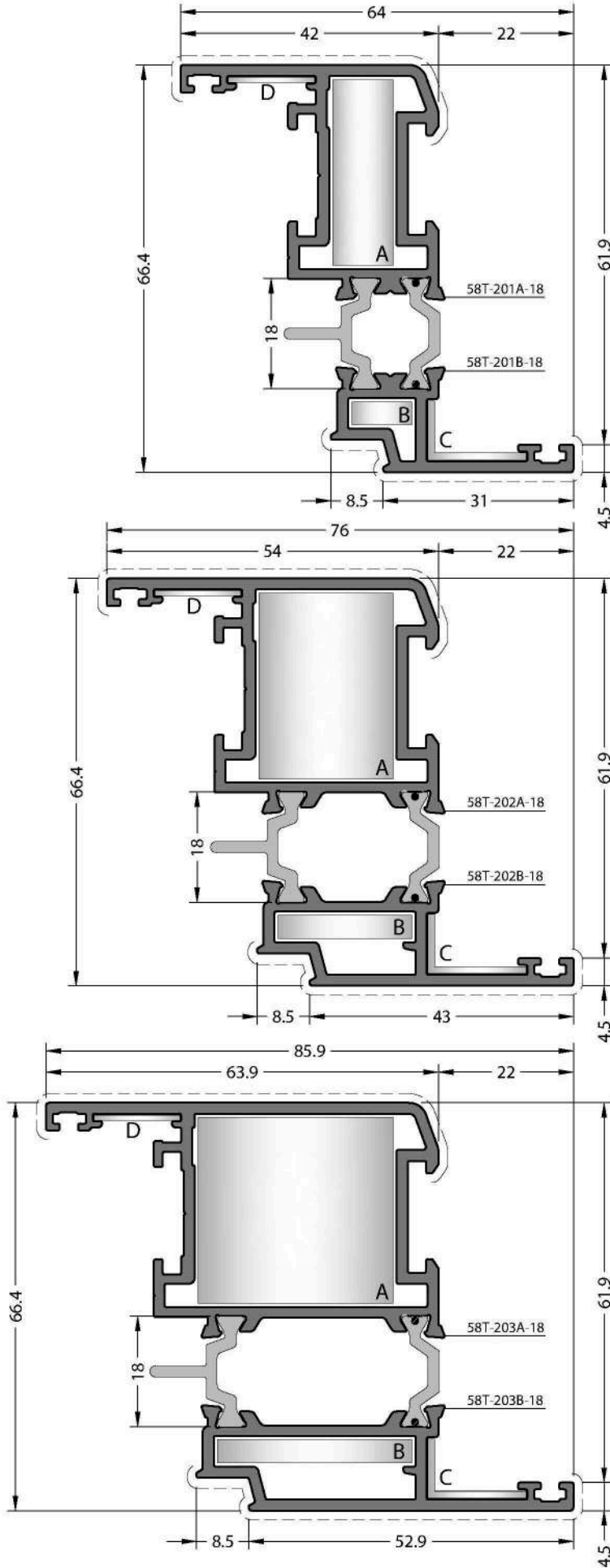

CODE / KOD

58T-201-18

THEORETICAL WEIGHT kg/m

TEORİK AĞIRLIK kg/m

1.420

CORNER JOINTS

KÖŞE BAĞLANTILAR



A CC-101-30.8



B CC-101-04.6



C EM58-22



D MK-20.1

CODE / KOD

58T-202-18

THEORETICAL WEIGHT kg/m

TEORİK AĞIRLIK kg/m

1.657

CORNER JOINTS

KÖŞE BAĞLANTILAR



A CC-103-30.8



B CC-103-04.6



C EM58-22



D MK-20.1

CODE / KOD

58T-203-18

THEORETICAL WEIGHT kg/m

TEORİK AĞIRLIK kg/m

1.850

CORNER JOINTS

KÖŞE BAĞLANTILAR



A CC-124-30.8



B CC-124-04.6



C EM58-22





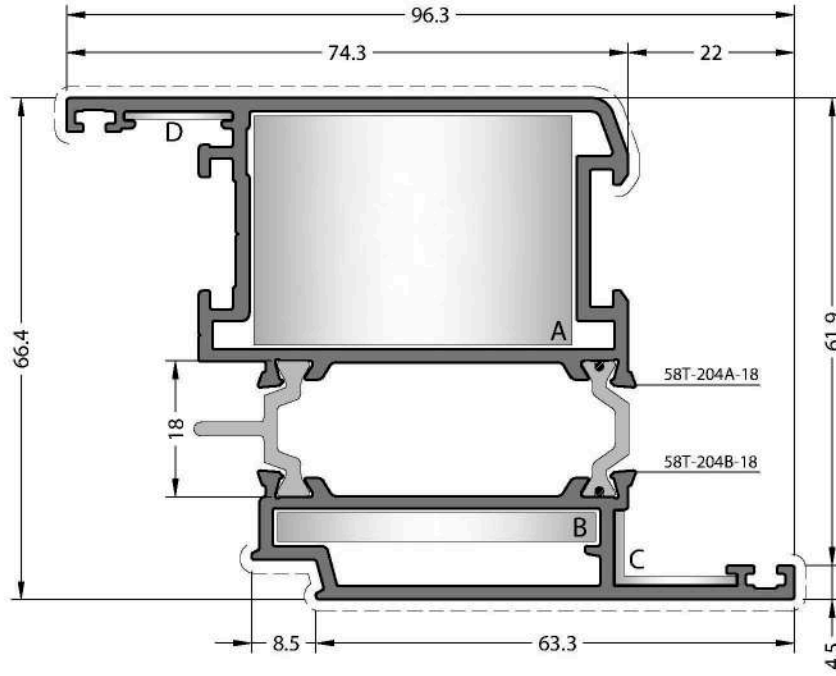

D MK-20.1



CODE / KOD
58T-204-18

THEORETICAL WEIGHT kg/m
TEORİK AĞIRLIK kg/m
2.037

CORNER JOINTS
KÖŞE BAĞLANTILAR



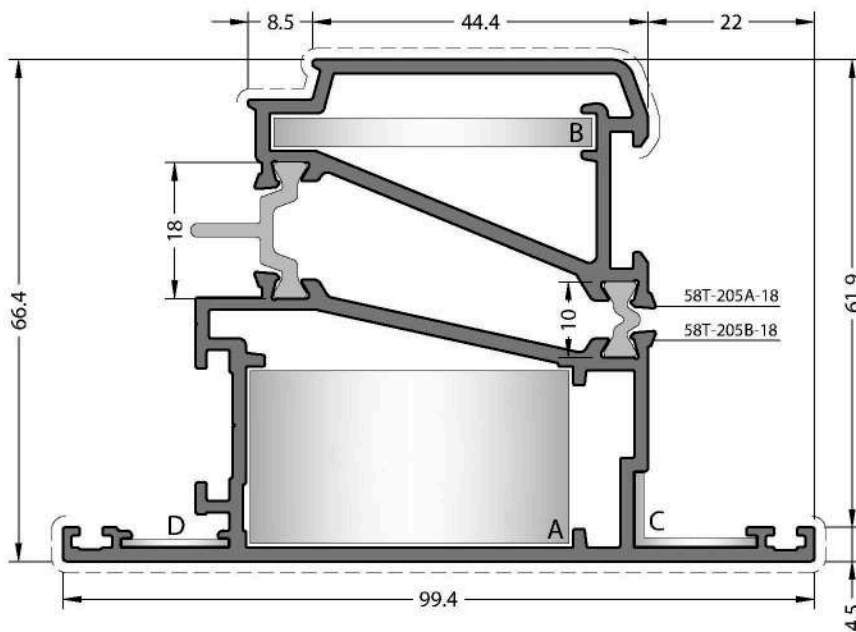

-  **A** CC-105-30.8
-  **B** CC-105-04.6
-  **C** EM58-22
-  **D** MK-20.1



CODE / KOD
58T-205-18

THEORETICAL WEIGHT kg/m
TEORİK AĞIRLIK kg/m
2.235

CORNER JOINTS
KÖŞE BAĞLANTILAR

-  **A** CC-105-23.6
-  **B** CC-105-04.6
-  **C** EM58-22
-  **D** MK-20.1

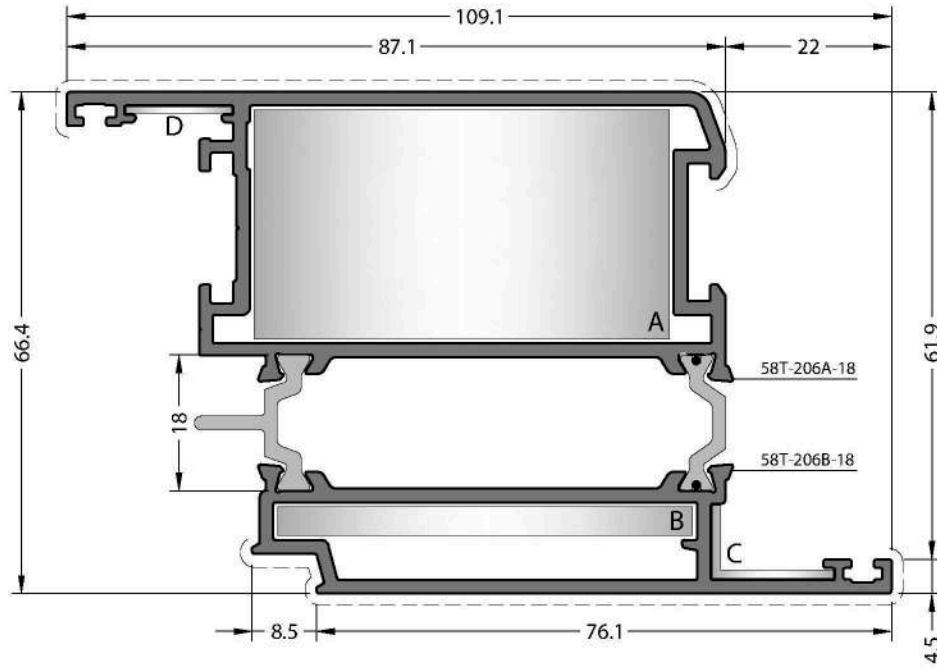

CODE / KOD

58T-206-18

THEORETICAL WEIGHT kg/m

TEORİK AĞIRLIK kg/m

2.311

CORNER JOINTS

KÖŞE BAĞLANTILAR



A CC-113-31.0



B CC-113-04.5



C EM58-22



D MK-20.1

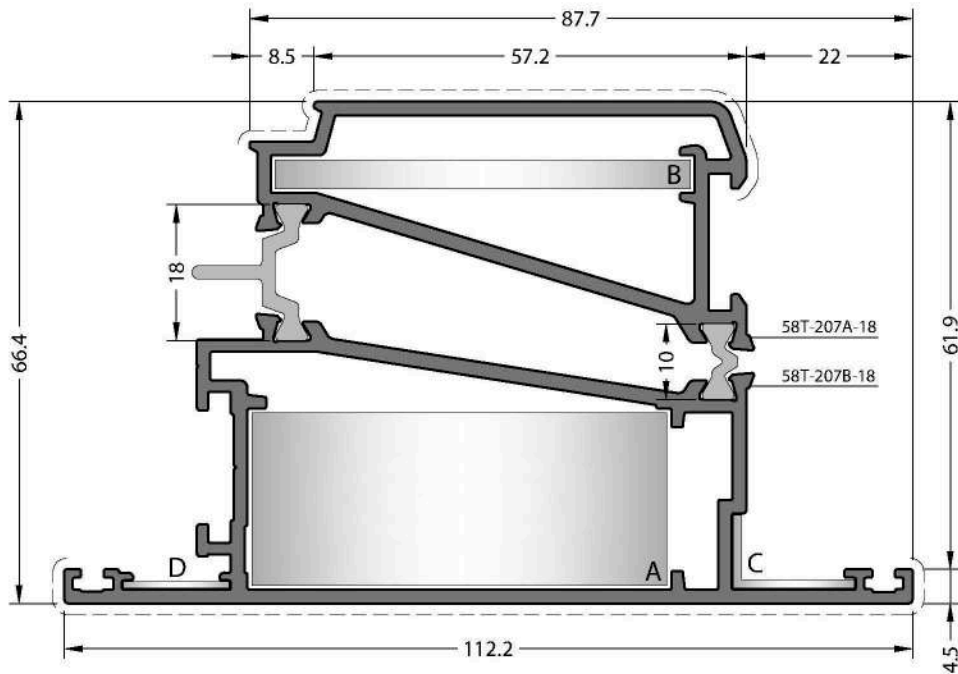

CODE / KOD

58T-207-18

THEORETICAL WEIGHT kg/m

TEORİK AĞIRLIK kg/m

2.495

CORNER JOINTS

KÖŞE BAĞLANTILAR



A CC-113-23.5



B CC-113-04.5



C EM58-22



D MK-20.1

Exterior Window Sash Profile / Dışa Açılır Pencere Kanat Profili

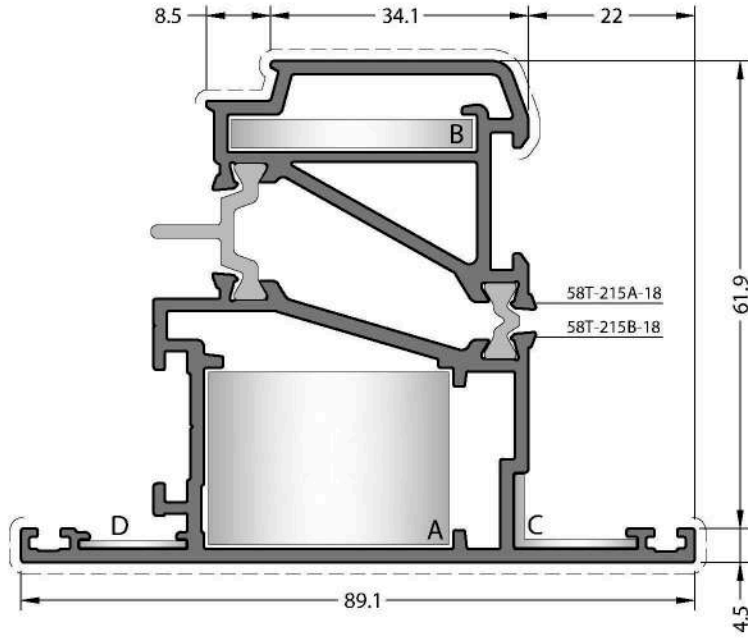

CODE / KOD

58T-215-18

THEORETICAL WEIGHT kg/m

TEORİK AĞIRLIK kg/m

2.103

CORNER JOINTS

KÖŞE BAĞLANTILAR



A CC-124-23.5



B CC-124-04.6



C EM58-22



D MK-20.1

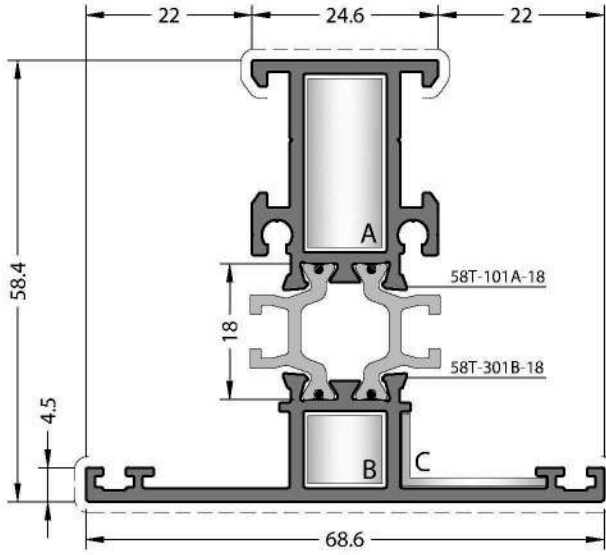

CODE / KOD

58T-301-18

THEORETICAL WEIGHT kg/m

TEORİK AĞIRLIK kg/m

1.360

T JUNCTION

ÇEKTİRME BAĞLANTI



A CC-903-10.5



FOR FRAME / KASA İÇİN

B CC-901-10.5



FOR SASH / KANAT İÇİN

B CC-902-10.5

CORNER JOINTS

KÖŞE BAĞLANTILAR



A CC-101-23.0



B CC-101-09.6



C EM58-21

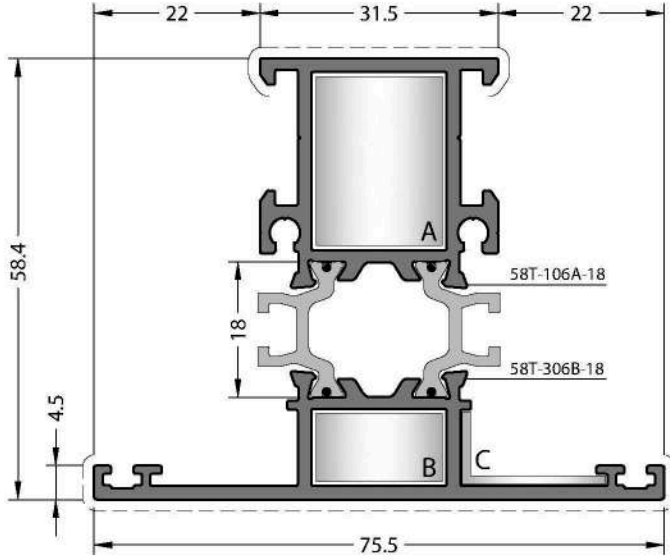

CODE / KOD

58T-306-18

THEORETICAL WEIGHT kg/m

TEORİK AĞIRLIK kg/m

1.510

T JUNCTION

ÇEKTİRME BAĞLANTI



A CC-903-17.4



FOR FRAME / KASA İÇİN

B CC-901-17.4



FOR SASH / KANAT İÇİN

B CC-902-17.4

CORNER JOINTS

KÖŞE BAĞLANTILAR



A CC-122-23.0



B CC-122-09.6



C EM58-21

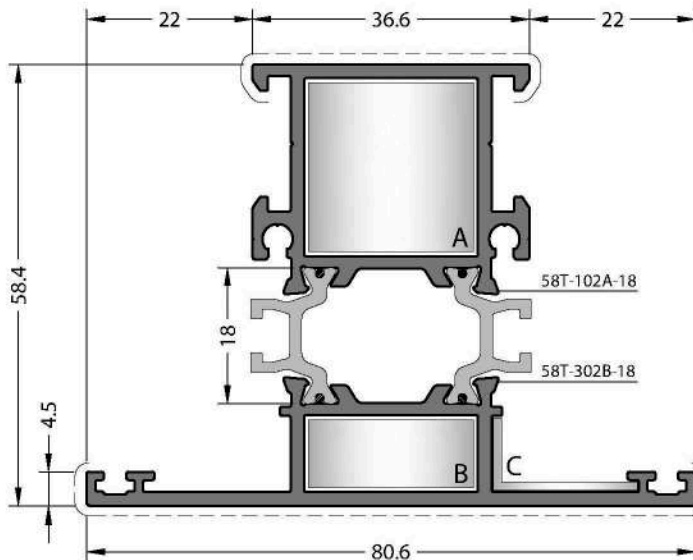

CODE / KOD

58T-302-18

THEORETICAL WEIGHT kg/m

TEORİK AĞIRLIK kg/m

1.604

T JUNCTION

ÇEKTİRME BAĞLANTI



A CC-903-22.5



FOR FRAME / KASA İÇİN

B CC-901-22.5



FOR SASH / KANAT İÇİN

B CC-902-22.5

CORNER JOINTS

KÖŞE BAĞLANTILAR



A CC-103-23.0



B CC-103-09.6



C EM58-21

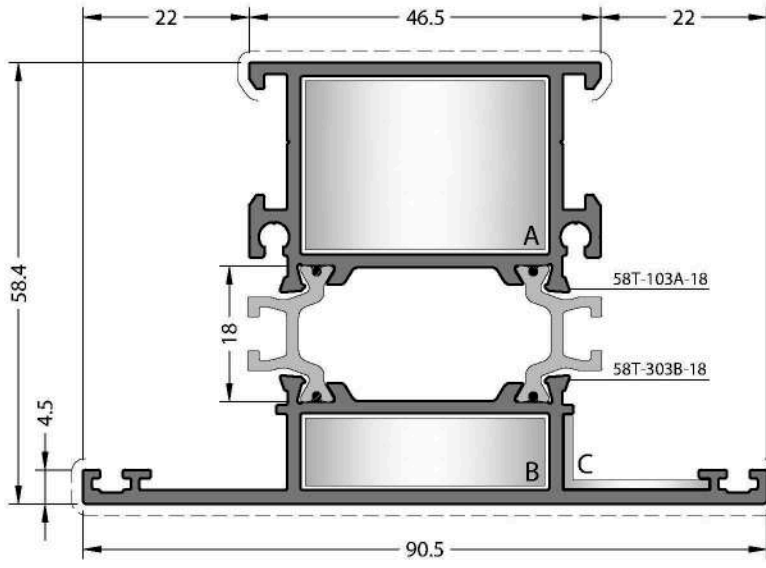

CODE / KOD

58T-303-18

THEORETICAL WEIGHT kg/m

TEORİK AĞIRLIK kg/m

1.791

T JUNCTION

ÇEKTİRME BAĞLANTI



A CC-903-32.4



FOR FRAME / KASA İÇİN

B CC-901-32.4



FOR SASH / KANAT İÇİN

B CC-902-32.4

CORNER JOINTS

KÖŞE BAĞLANTILAR



A CC-124-23.0



B CC-124-09.6



C EM58-21

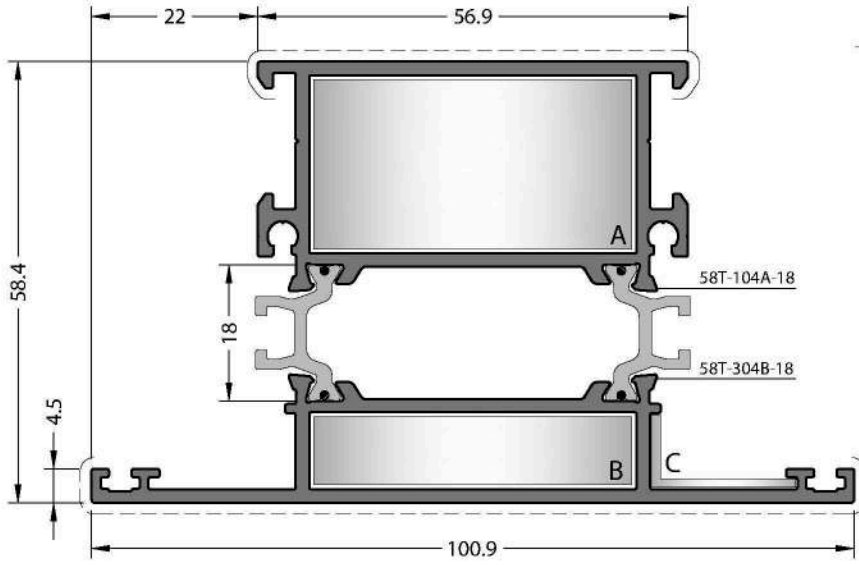

CODE / KOD

58T-304-18

THEORETICAL WEIGHT kg/m

TEORİK AĞIRLIK kg/m

1.992

T JUNCTION

ÇEKTİRME BAĞLANTI



A CC-903-42.8



FOR FRAME / KASA İÇİN

B CC-901-42.8



FOR SASH / KANAT İÇİN

B CC-902-42.8

CORNER JOINTS

KÖŞE BAĞLANTILAR



A CC-105-23.0



B CC-105-09.6



C EM58-21

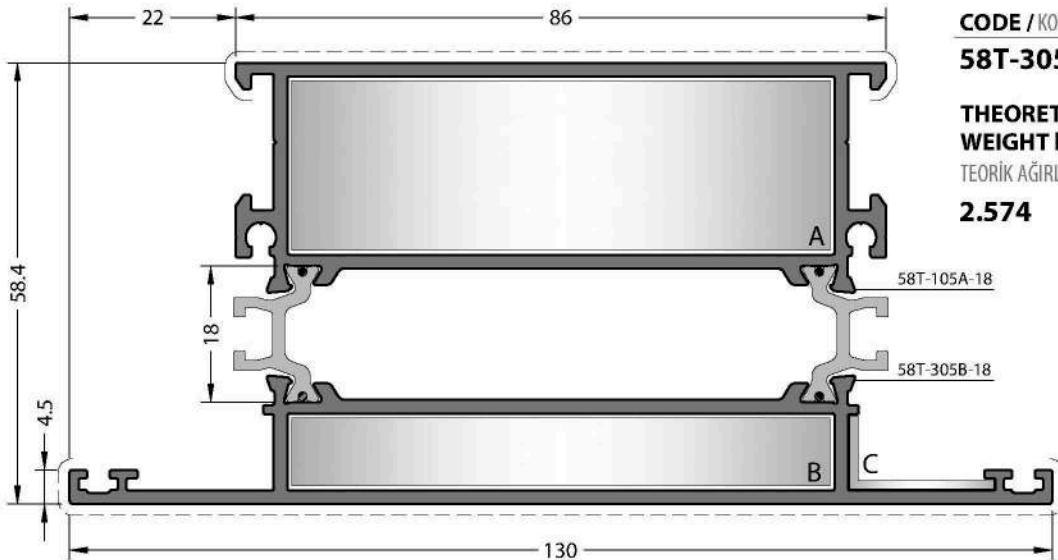

CODE / KOD

58T-305-18

THEORETICAL WEIGHT kg/m

TEORİK AĞIRLIK kg/m

2.574

T JUNCTION

ÇEKTİRME BAĞLANTI



A CC-903-71.9



FOR FRAME / KASA İÇİN

B CC-901-71.9



FOR SASH / KANAT İÇİN

B CC-902-71.9

CORNER JOINTS

KÖŞE BAĞLANTILAR



A CC-114-23.0



B CC-114-09.6



C EM58-21

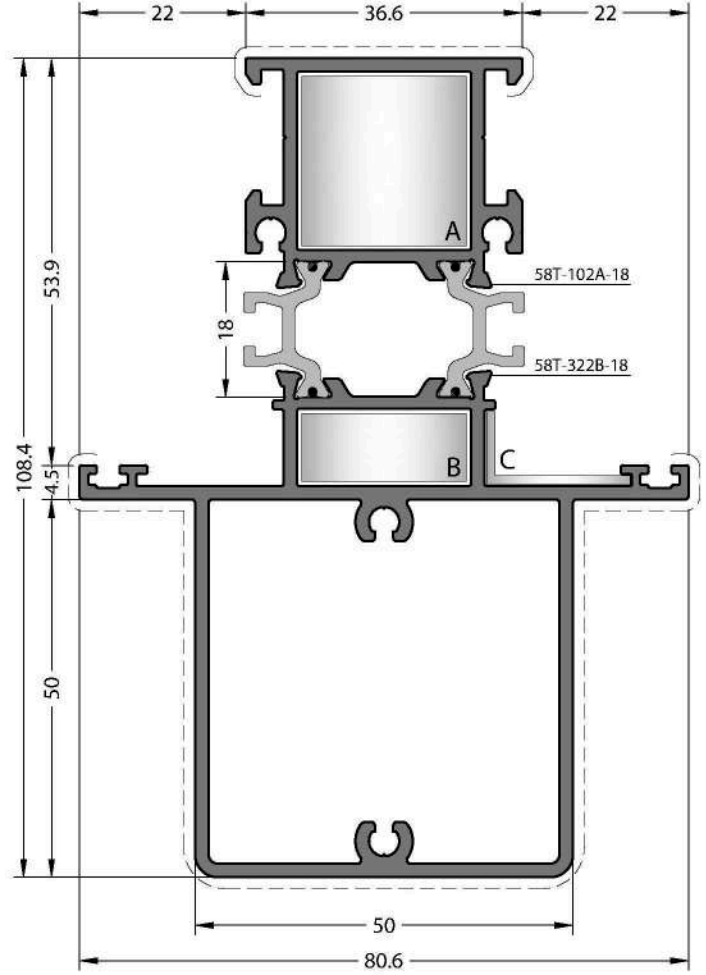
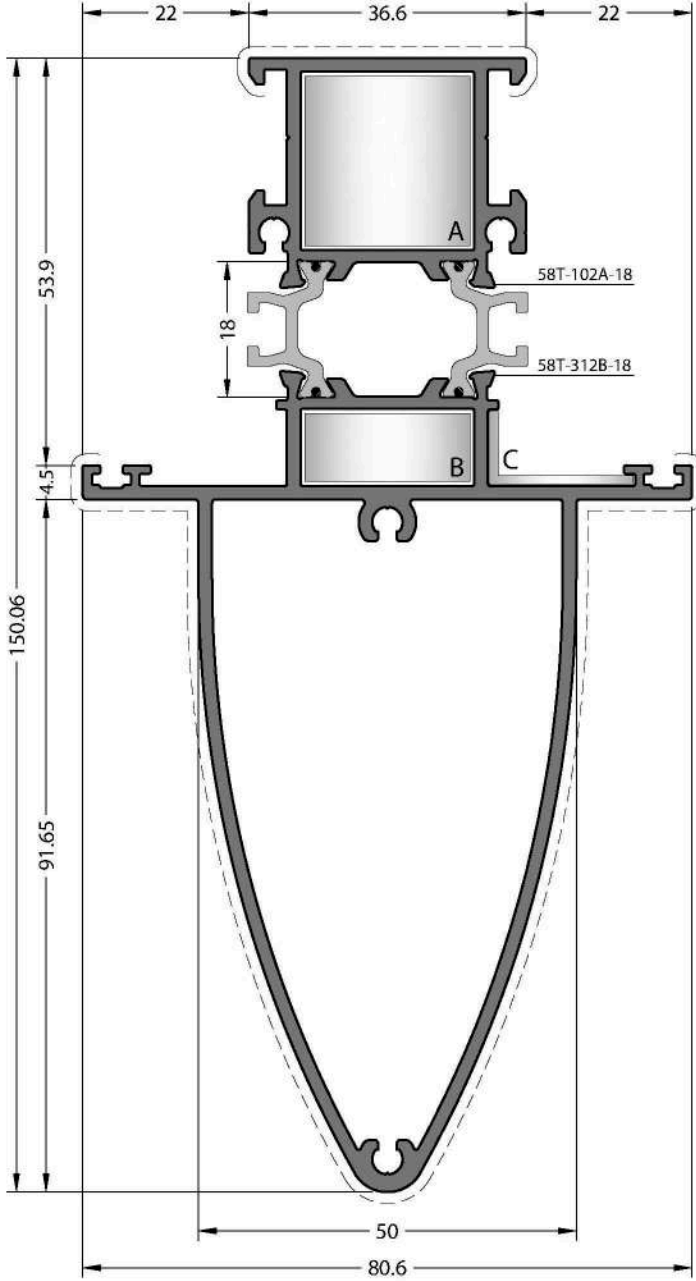



CODE / KOD
58T-322-18

THEORETICAL WEIGHT kg/m
TEORİK AĞIRLIK kg/m
2.438

T JUNCTION
ÇEKTİRME BAĞLANTI

-  **A** CC-903-22.5
- FOR FRAME / KASA İÇİN**
-  **B** CC-901-22.5
- FOR SASH / KANAT İÇİN**
-  **B** CC-902-22.5

CORNER JOINTS
KÖŞE BAĞLANTILAR

-  **A** CC-103-23.0
-  **B** CC-103-09.6
-  **C** EM58-21



CODE / KOD
58T-312-18

THEORETICAL WEIGHT kg/m
TEORİK AĞIRLIK kg/m
2.650

T JUNCTION
ÇEKTİRME BAĞLANTI

-  **A** CC-903-22.5
- FOR FRAME / KASA İÇİN**
-  **B** CC-901-22.5
- FOR SASH / KANAT İÇİN**
-  **B** CC-902-22.5

CORNER JOINTS
KÖŞE BAĞLANTILAR

-  **A** CC-103-23.0
-  **B** CC-103-09.6
-  **C** EM58-21

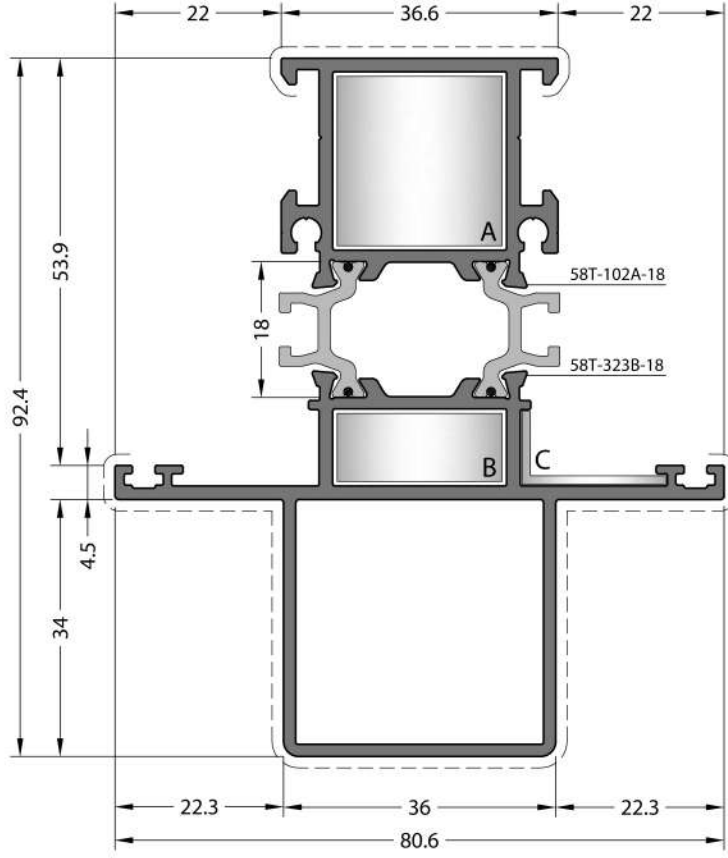

CODE / KOD
58T-323-18

THEORETICAL
WEIGHT kg/m
TEORİK AĞIRLIK kg/m
2.036

T JUNCTION
ÇEKTİRME BAĞLANTI



A CC-903-22.5



FOR FRAME / KASA İÇİN

B CC-901-22.5



FOR SASH / KANAT İÇİN

B CC-902-22.5

CORNER JOINTS
KÖŞE BAĞLANTILAR



A CC-103-23.0



B CC-103-09.6



C EM58-21

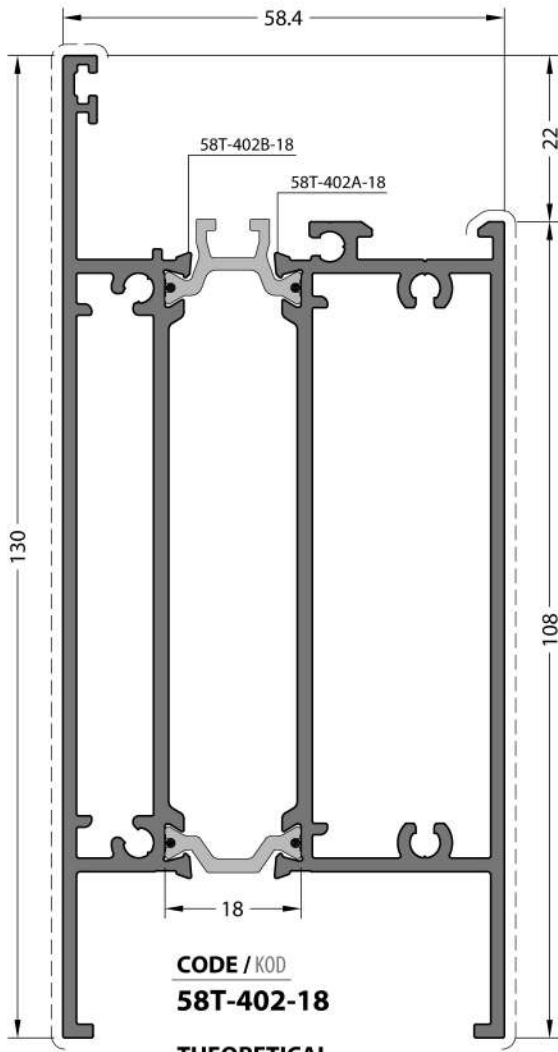

CODE / KOD
58T-402-18
THEORETICAL
WEIGHT kg/m
TEORİK AĞIRLIK kg/m
2.886

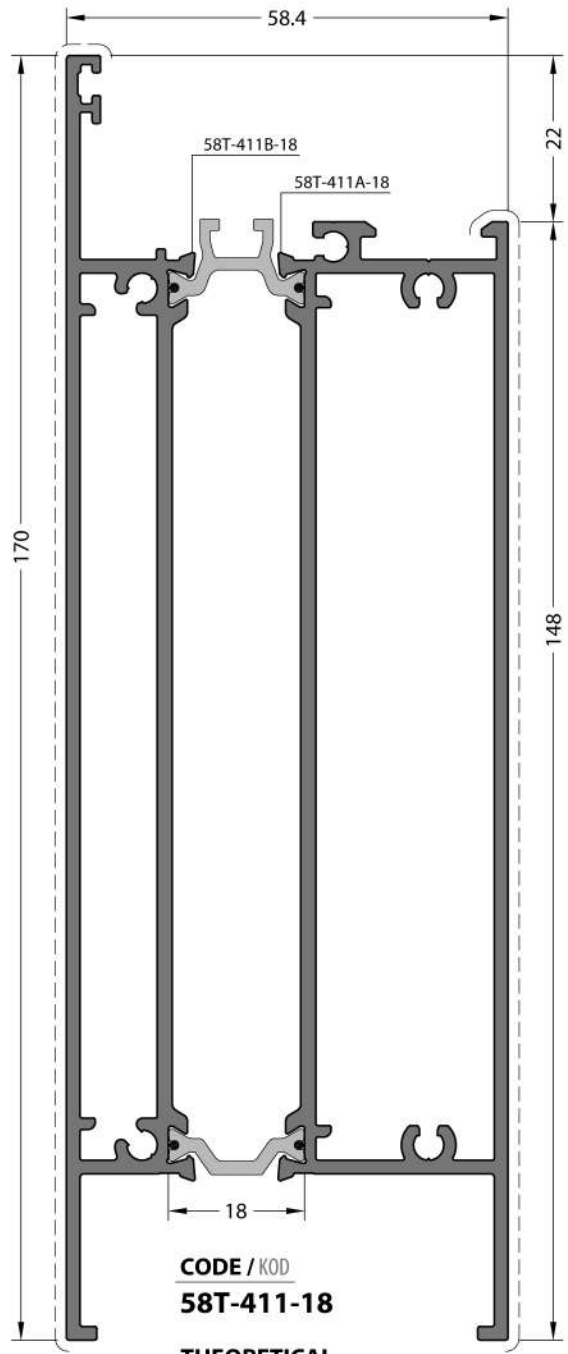

CODE / KOD
58T-411-18
THEORETICAL
WEIGHT kg/m
TEORİK AĞIRLIK kg/m
3.190

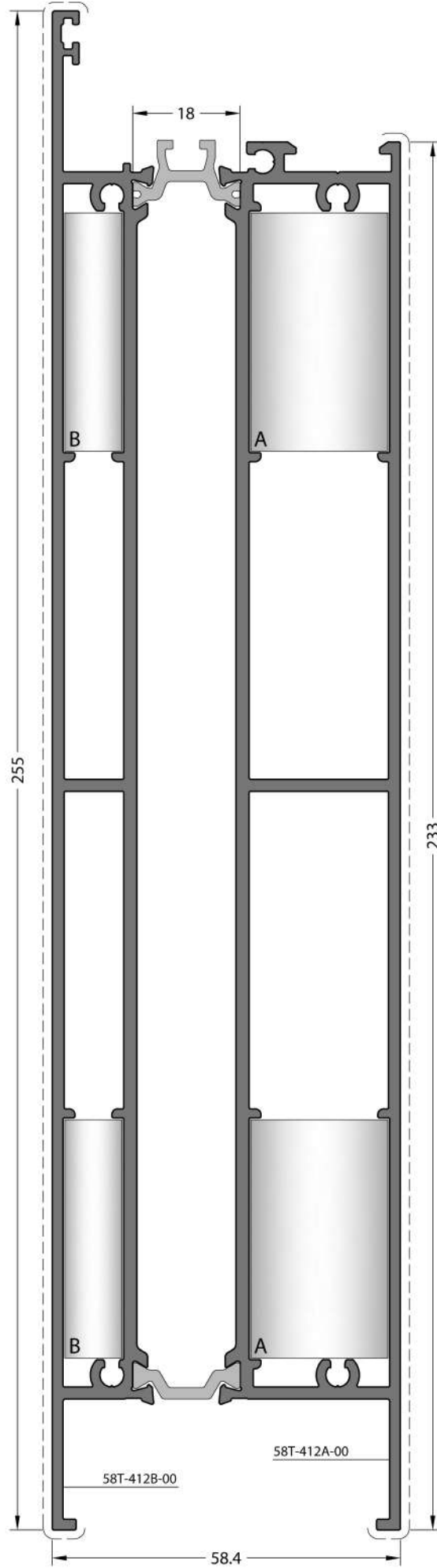

CODE / KOD

58T-412-00

**THEORETICAL
WEIGHT kg/m**

TEORİK AĞIRLIK kg/m

6.044

T JUNCTION

ÇEKTİRME BAĞLANTI



A CC-903-40.0



B CC-902-40.0

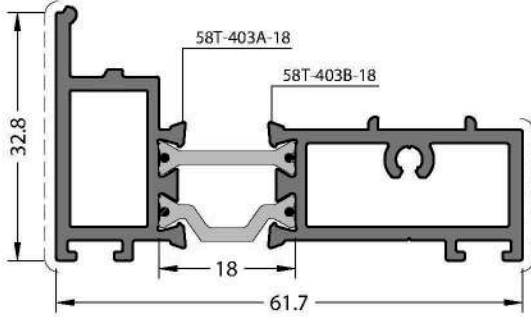

CODE / KOD
58T-403-18

THEORETICAL WEIGHT kg/m
TEORİK AĞIRLIK kg/m
1.079

ADAPTER CAP
ADAPTÖR KAPAĞI

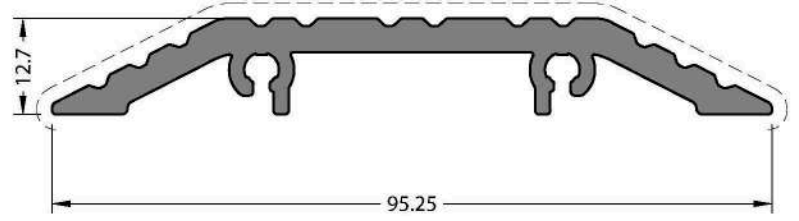

CODE / KOD
20-162-00

THEORETICAL WEIGHT kg/m
TEORİK AĞIRLIK kg/m
1.269

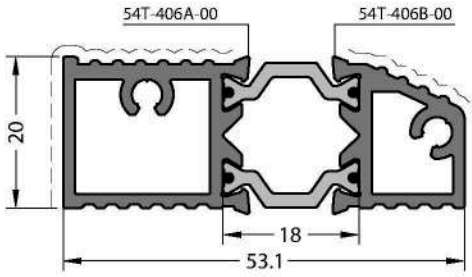

CODE / KOD
60T-406-00

THEORETICAL WEIGHT kg/m
TEORİK AĞIRLIK kg/m
0.932

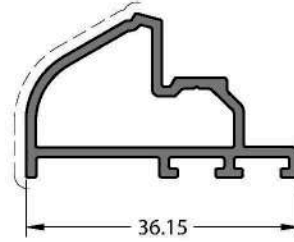

CODE / KOD
58T-405-00

THEORETICAL WEIGHT kg/m
TEORİK AĞIRLIK kg/m
0.374

DROPPER CAP
DAMLALIK KAPAĞI

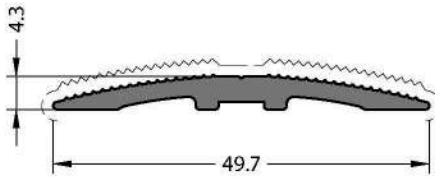

CODE / KOD
20-101-00

THEORETICAL WEIGHT kg/m
TEORİK AĞIRLIK kg/m
0.354

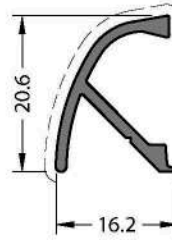

CODE / KOD
07-211-00

THEORETICAL WEIGHT kg/m
TEORİK AĞIRLIK kg/m
0.183

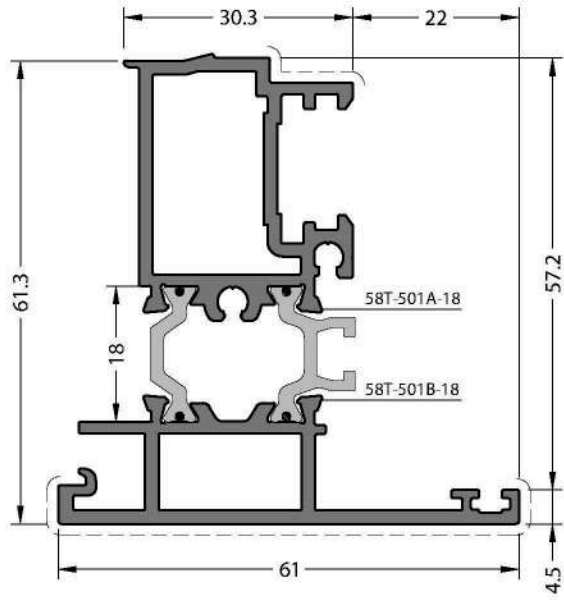

CODE / KOD
58T-501-18

THEORETICAL WEIGHT kg/m
TEORİK AĞIRLIK kg/m
1.511

ADAPTER CAP
ADAPTÖR KAPAĞI



EM58T-501

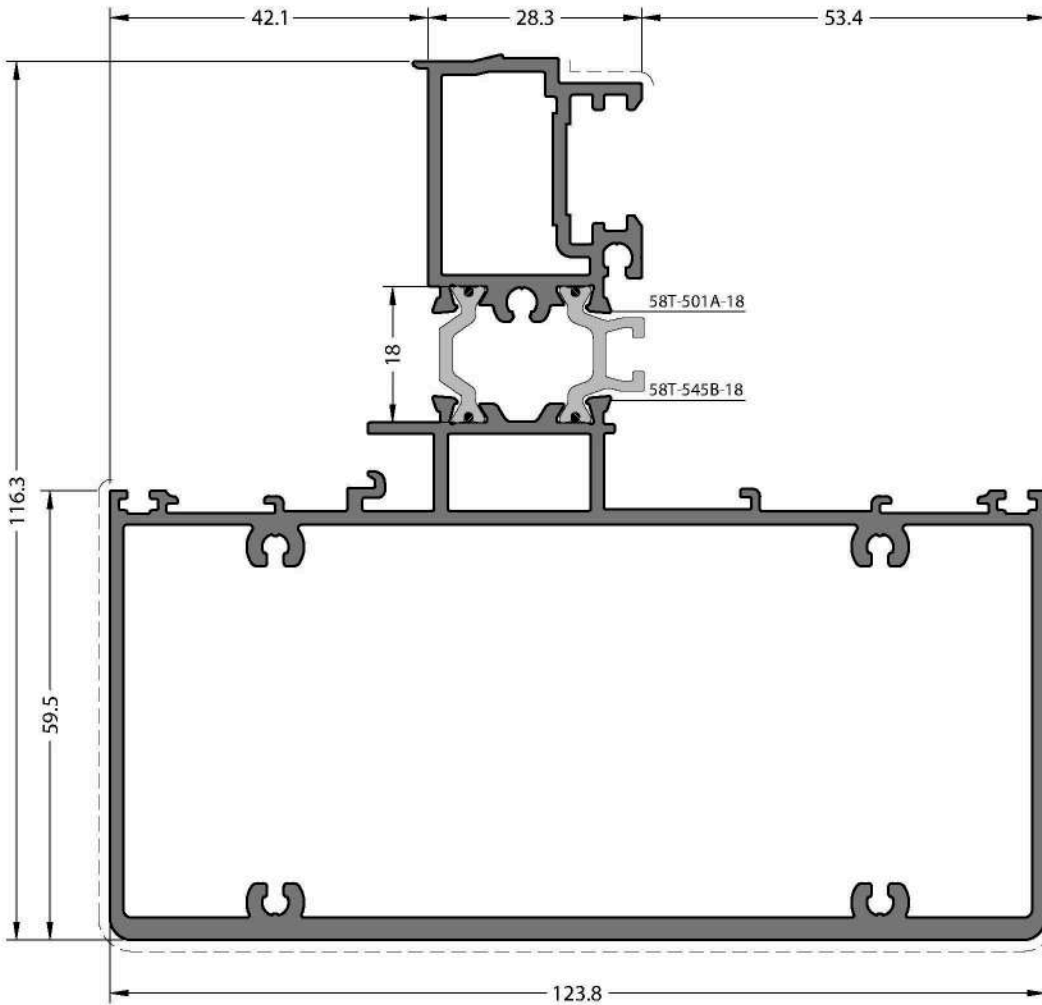

CODE / KOD
58T-545-18

THEORETICAL WEIGHT kg/m
TEORİK AĞIRLIK kg/m
1.511

ADAPTER CAP
ADAPTÖR KAPAĞI



EM58T-501



EM58T-545B

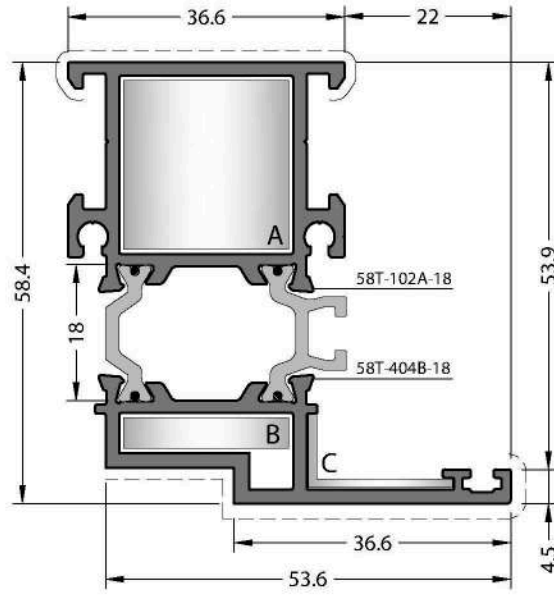

CODE / KOD

58T-404-18

THEORETICAL WEIGHT kg/m

TEORİK AĞIRLIK kg/m

1.439

CORNER JOINTS

KÖŞE BAĞLANTILAR



A CC-103-23.0



B CC-103-04.6



C EM58-21

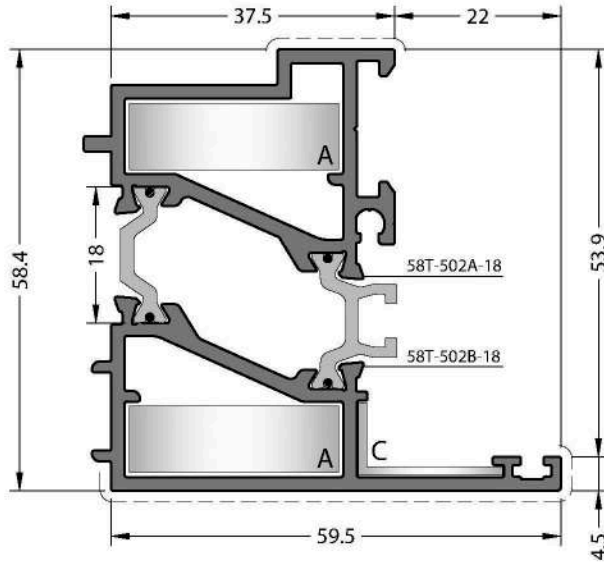

CODE / KOD

58T-502-18

THEORETICAL WEIGHT kg/m

TEORİK AĞIRLIK kg/m

1.583

CORNER JOINTS

KÖŞE BAĞLANTILAR



A CC-123-09.5



B CC-123-09.5



C EM58-21

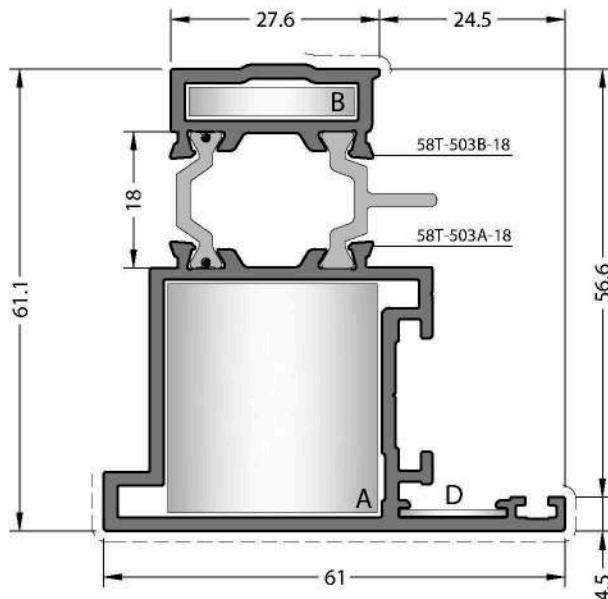

CODE / KOD

58T-503-18

THEORETICAL WEIGHT kg/m

TEORİK AĞIRLIK kg/m

1.461

CORNER JOINTS

KÖŞE BAĞLANTILAR



A CC-123-31.0



B CC-103-04.6



D MK-20.1

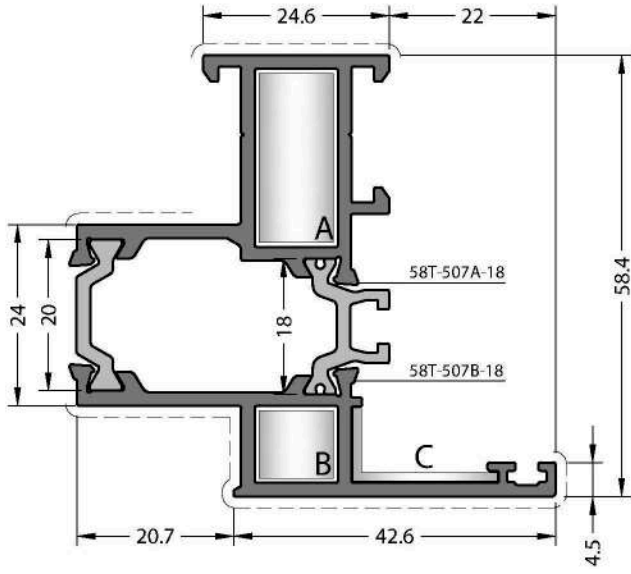

CODE / KOD
58T-507-18

THEORETICAL WEIGHT kg/m
TEORİK AĞIRLIK kg/m
1.363

CORNER JOINTS
KÖŞE BAĞLANTILAR

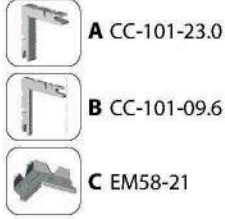

Application Details / Uygulama Detayı

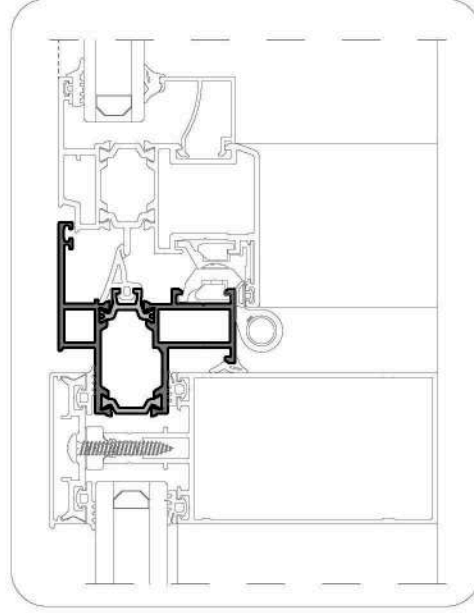

Applicable Profiles
Uygulanabilir Profiller

58T Sash Profiles
58T Kanat Profilleri

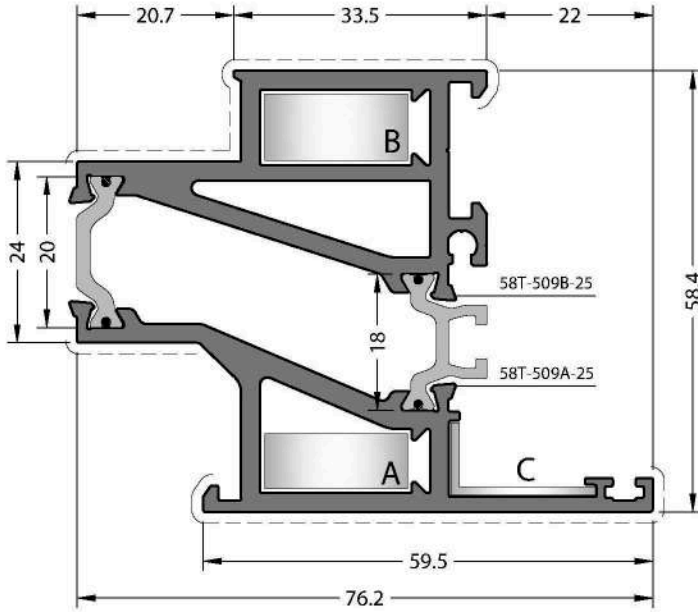

CODE / KOD
58T-509-25

THEORETICAL WEIGHT kg/m
TEORİK AĞIRLIK kg/m
2.304

CORNER JOINTS
KÖŞE BAĞLANTILAR

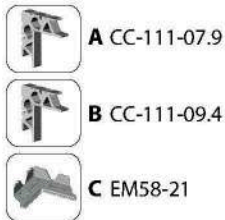

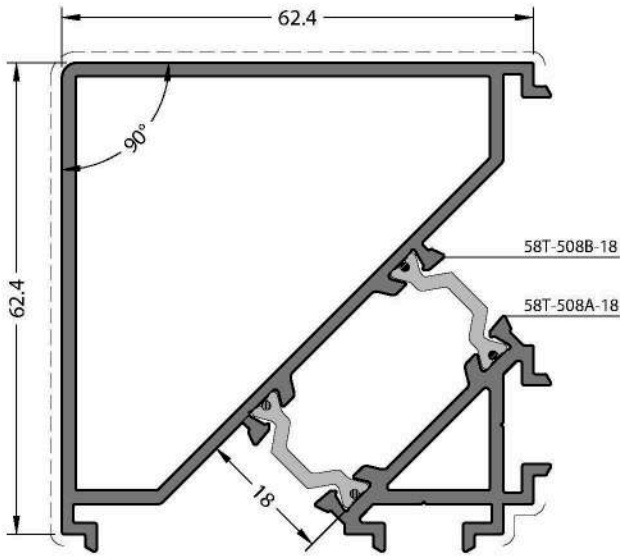

CODE / KOD
58T-508-18

THEORETICAL WEIGHT kg/m
TEORİK AĞIRLIK kg/m
1.720

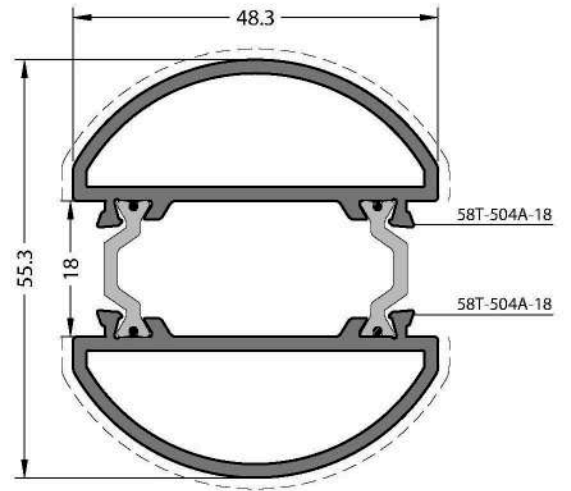

CODE / KOD
58T-504-18

THEORETICAL WEIGHT kg/m
TEORİK AĞIRLIK kg/m
1.332

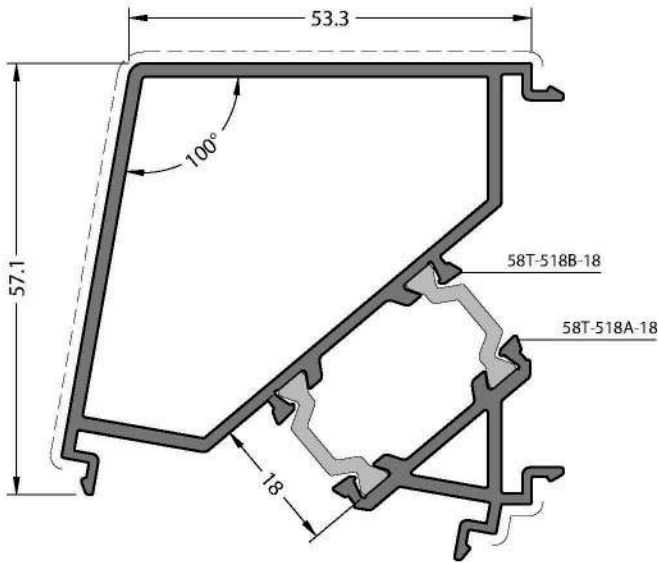

CODE / KOD
58T-518-18

THEORETICAL WEIGHT kg/m
TEORİK AĞIRLIK kg/m
1.532

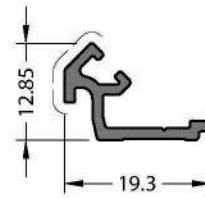

CODE / KOD
07-112-00

THEORETICAL WEIGHT kg/m
TEORİK AĞIRLIK kg/m
0.148

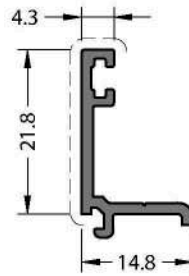

CODE / KOD
58T-511-00

THEORETICAL WEIGHT kg/m
TEORİK AĞIRLIK kg/m
0.183

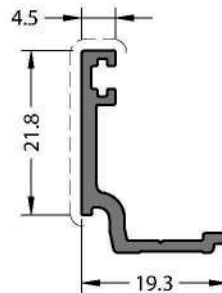

CODE / KOD
07-111-00

THEORETICAL WEIGHT kg/m
TEORİK AĞIRLIK kg/m
0.233

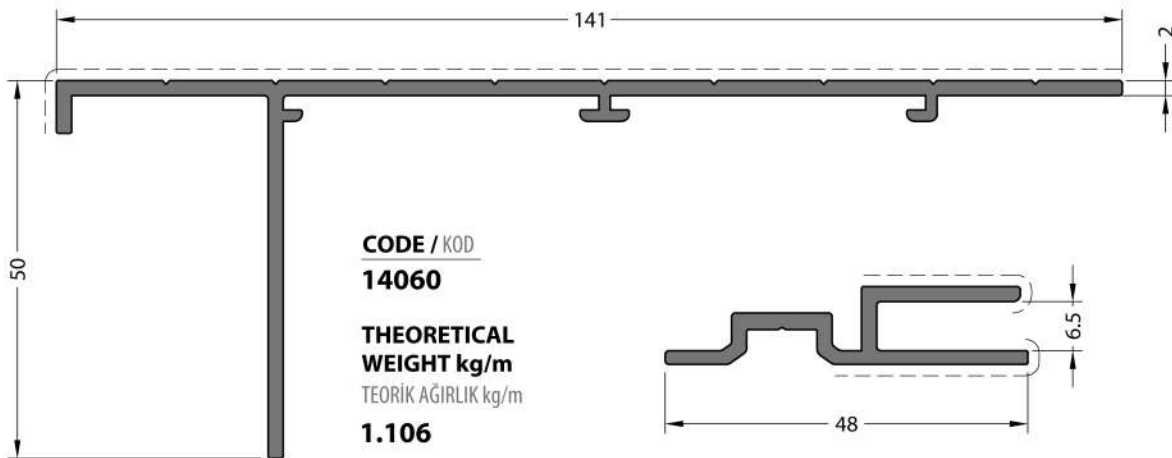
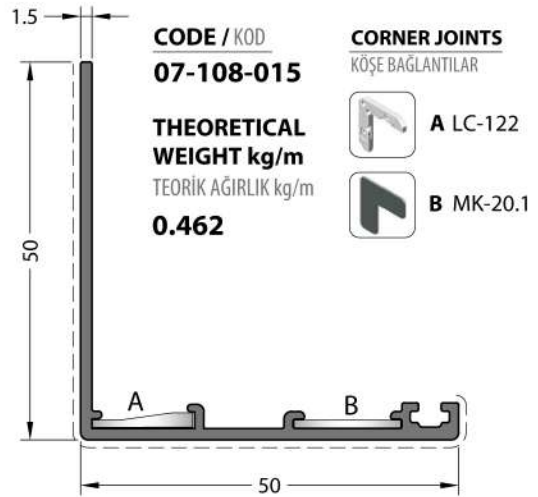
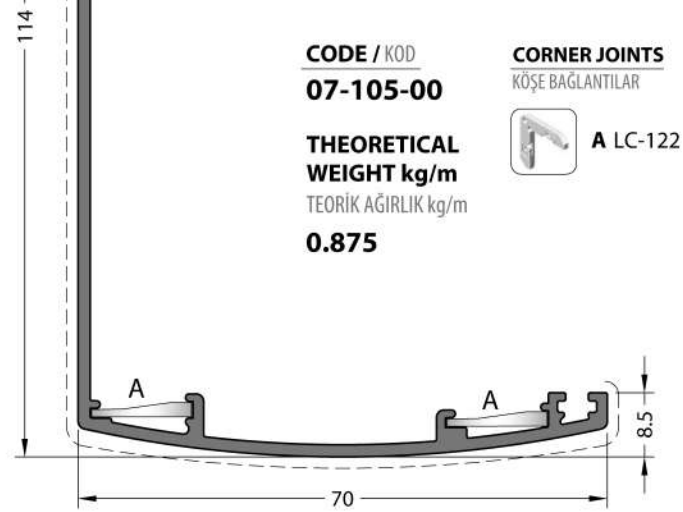
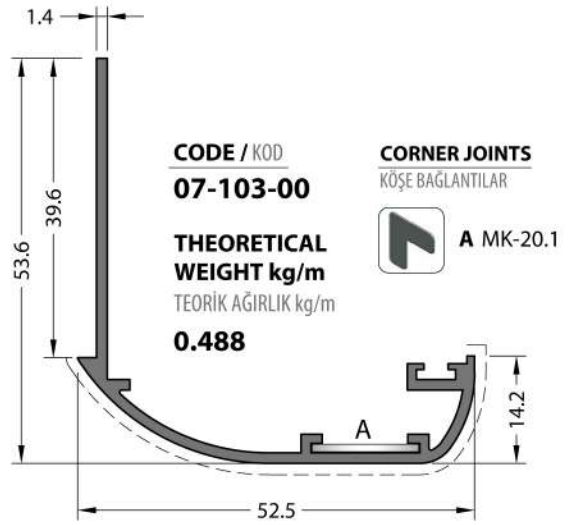
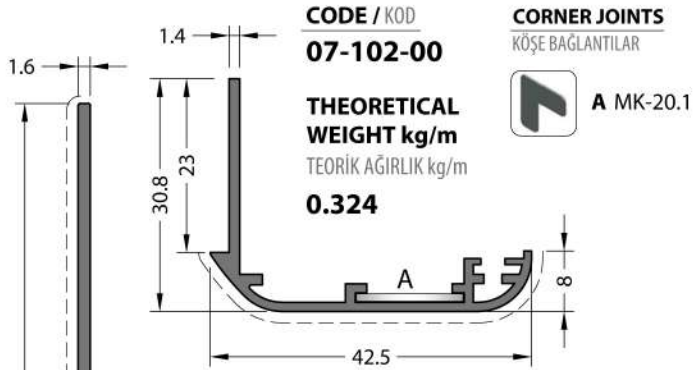

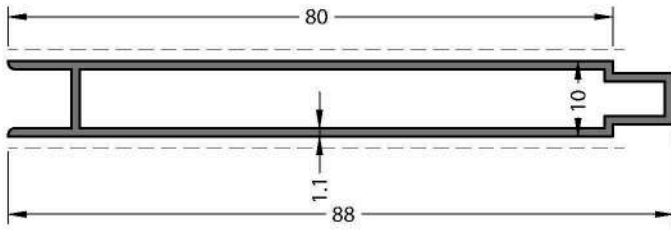

CODE / KOD
07-131-011

THEORETICAL WEIGHT kg/m
TEORİK AĞIRLIK kg/m
0.568

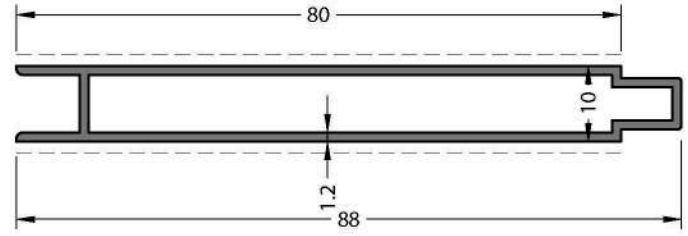

CODE / KOD
07-131-012

THEORETICAL WEIGHT kg/m
TEORİK AĞIRLIK kg/m
0.618

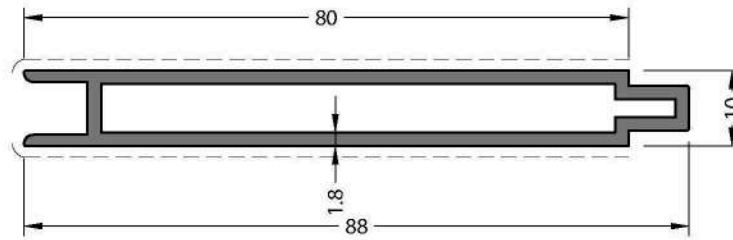

CODE / KOD
07-131-018

THEORETICAL WEIGHT kg/m
TEORİK AĞIRLIK kg/m
0.902

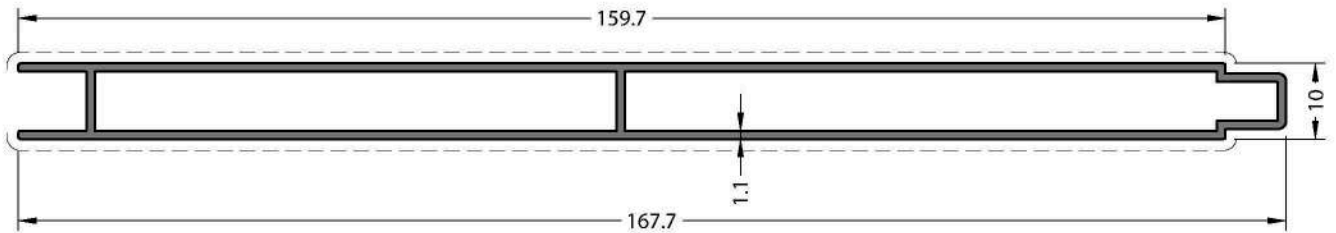

CODE / KOD
07-133-011

THEORETICAL WEIGHT kg/m
TEORİK AĞIRLIK kg/m
1.064

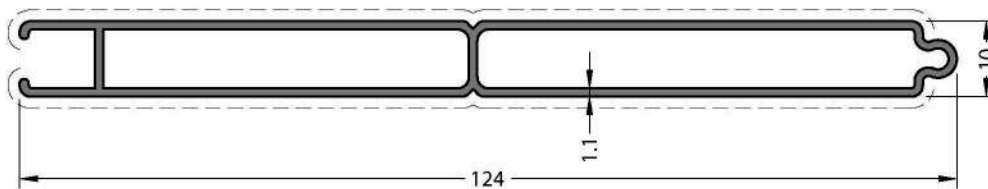

CODE / KOD
07-132-011

THEORETICAL WEIGHT kg/m
TEORİK AĞIRLIK kg/m
0.802

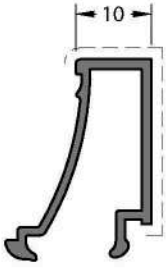

CODE / KOD
08-103-00

THEORETICAL WEIGHT kg/m
TEORİK AĞIRLIK kg/m
0.237

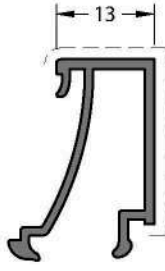

CODE / KOD
08-104-00

THEORETICAL WEIGHT kg/m
TEORİK AĞIRLIK kg/m
0.256

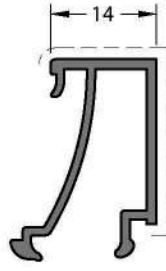

CODE / KOD
08-105-00

THEORETICAL WEIGHT kg/m
TEORİK AĞIRLIK kg/m
0.260

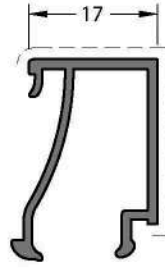

CODE / KOD
08-107-00

THEORETICAL WEIGHT kg/m
TEORİK AĞIRLIK kg/m
0.262



CODE / KOD
08-108-00

THEORETICAL WEIGHT kg/m
TEORİK AĞIRLIK kg/m
0.269

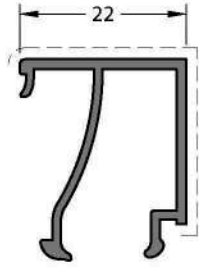

CODE / KOD
08-109-00

THEORETICAL WEIGHT kg/m
TEORİK AĞIRLIK kg/m
0.280

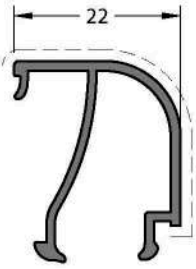

CODE / KOD
08-110-00

THEORETICAL WEIGHT kg/m
TEORİK AĞIRLIK kg/m
0.266



CODE / KOD
08-111-00

THEORETICAL WEIGHT kg/m
TEORİK AĞIRLIK kg/m
0.216

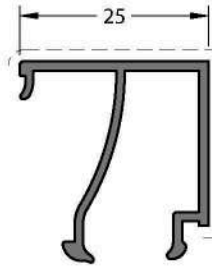

CODE / KOD
08-112-00

THEORETICAL WEIGHT kg/m
TEORİK AĞIRLIK kg/m
0.291

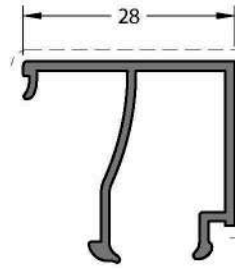

CODE / KOD
08-113-00

THEORETICAL WEIGHT kg/m
TEORİK AĞIRLIK kg/m
0.300

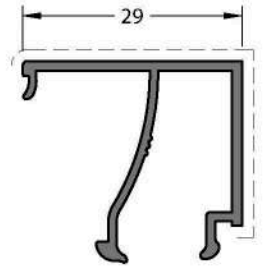

CODE / KOD
08-114-00

THEORETICAL WEIGHT kg/m
TEORİK AĞIRLIK kg/m
0.306

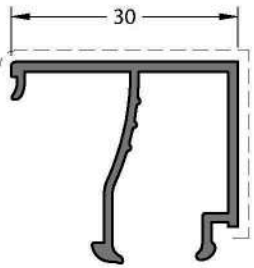

CODE / KOD
08-117-00

THEORETICAL WEIGHT kg/m
TEORİK AĞIRLIK kg/m
0.309

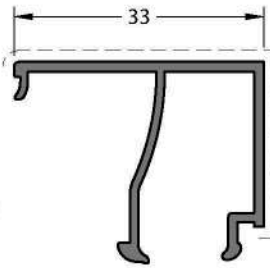

CODE / KOD
08-115-00

THEORETICAL WEIGHT kg/m
TEORİK AĞIRLIK kg/m
0.317

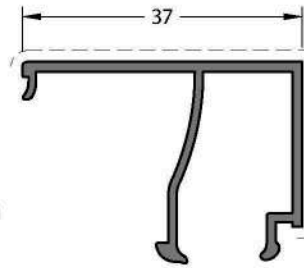

CODE / KOD
08-116-00

THEORETICAL WEIGHT kg/m
TEORİK AĞIRLIK kg/m
0.331

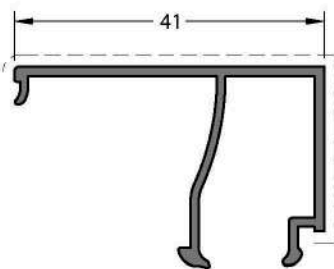

CODE / KOD
08-120-00

THEORETICAL WEIGHT kg/m
TEORİK AĞIRLIK kg/m
0.345

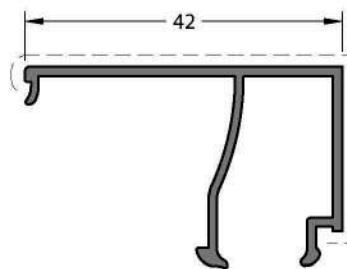

CODE / KOD
08-121-00

THEORETICAL WEIGHT kg/m
TEORİK AĞIRLIK kg/m
0.349

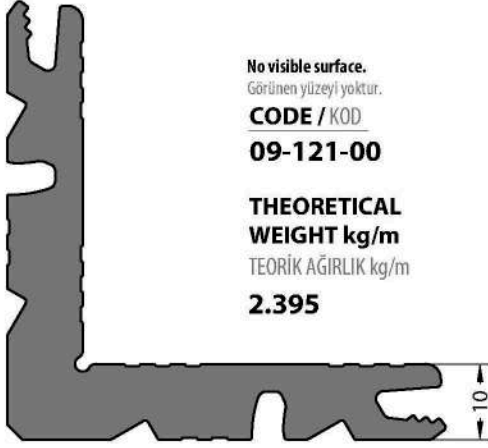

No visible surface.
Görünen yüzeyi yoktur.

CODE / KOD

09-121-00

**THEORETICAL
WEIGHT kg/m**

TEORİK AĞIRLIK kg/m

2.395

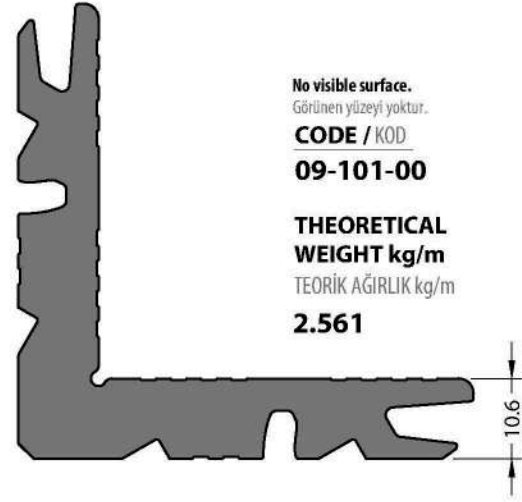

No visible surface.
Görünen yüzeyi yoktur.

CODE / KOD

09-101-00

**THEORETICAL
WEIGHT kg/m**

TEORİK AĞIRLIK kg/m

2.561

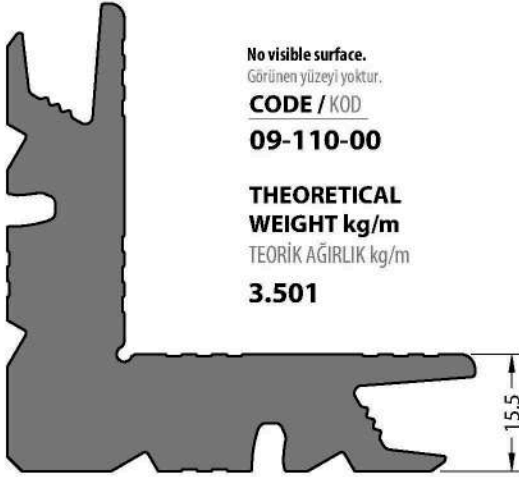

No visible surface.
Görünen yüzeyi yoktur.

CODE / KOD

09-110-00

**THEORETICAL
WEIGHT kg/m**

TEORİK AĞIRLIK kg/m

3.501

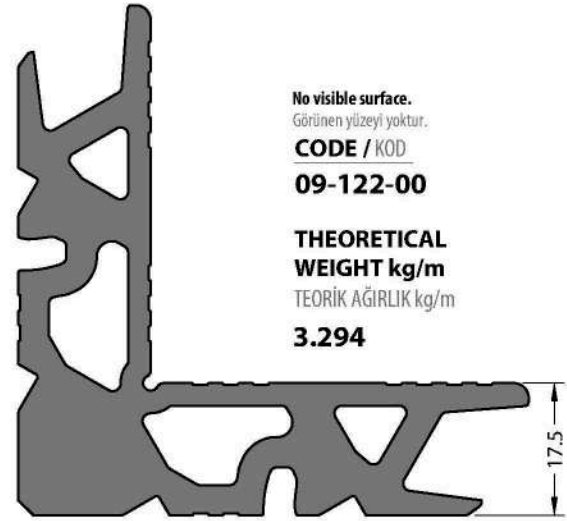

No visible surface.
Görünen yüzeyi yoktur.

CODE / KOD

09-122-00

**THEORETICAL
WEIGHT kg/m**

TEORİK AĞIRLIK kg/m

3.294

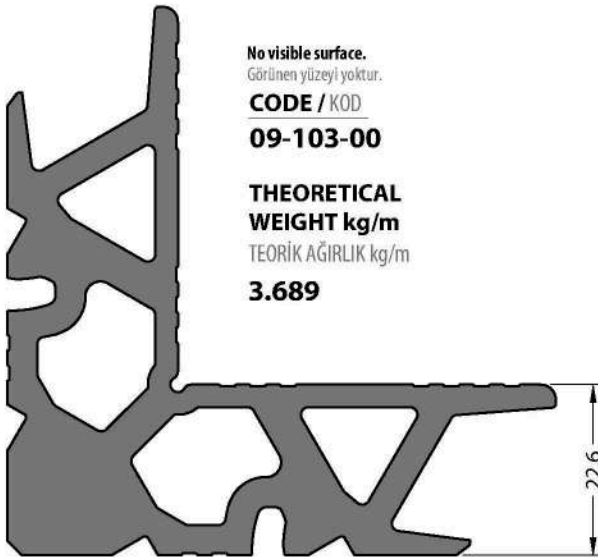

No visible surface.
Görünen yüzeyi yoktur.

CODE / KOD

09-103-00

**THEORETICAL
WEIGHT kg/m**

TEORİK AĞIRLIK kg/m

3.689

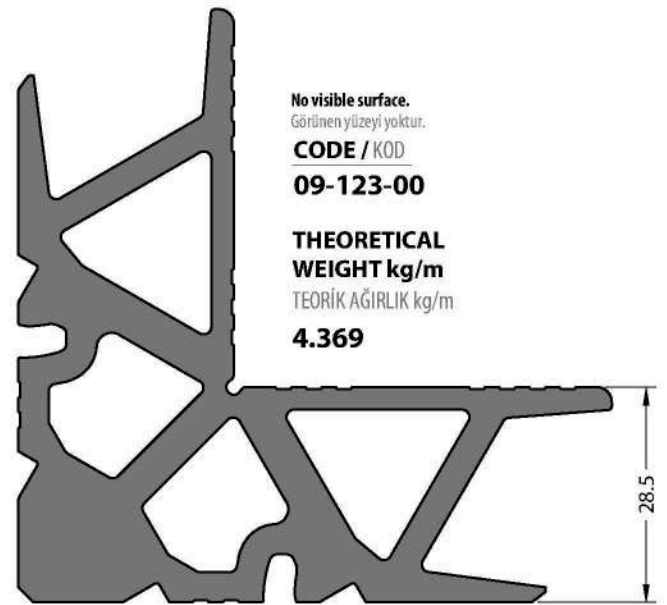

No visible surface.
Görünen yüzeyi yoktur.

CODE / KOD

09-123-00

**THEORETICAL
WEIGHT kg/m**

TEORİK AĞIRLIK kg/m

4.369

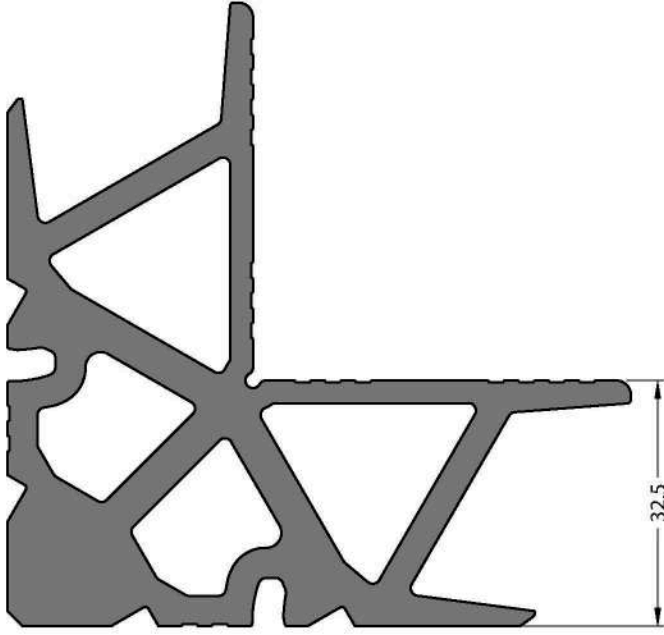

No visible surface.
Görünen yüzeyi yoktur.

CODE / KOD

09-124-00

**THEORETICAL
WEIGHT kg/m**

TEORİK AĞIRLIK kg/m

4.572

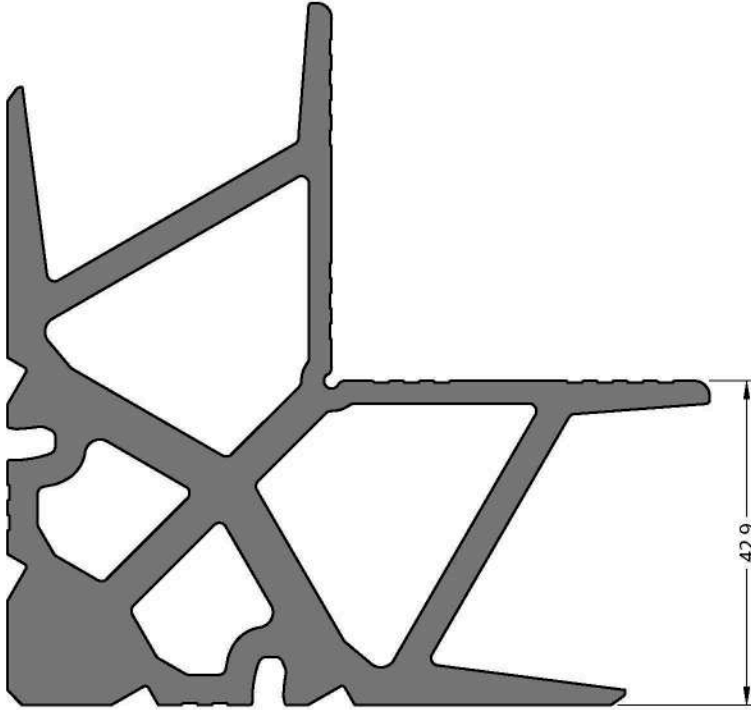

No visible surface.
Görünen yüzeyi yoktur.

CODE / KOD

09-105-00

**THEORETICAL
WEIGHT kg/m**

TEORİK AĞIRLIK kg/m

5.453

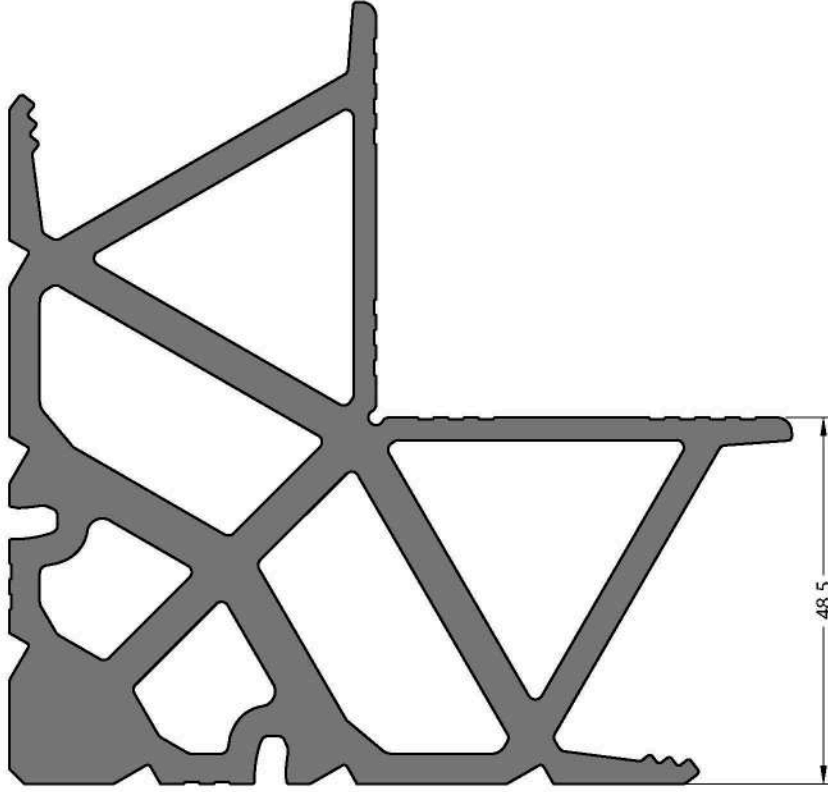

No visible surface.
Görünen yüzeyi yoktur.

CODE / KOD

09-117-00

**THEORETICAL
WEIGHT kg/m**

TEORİK AĞIRLIK kg/m

7.012

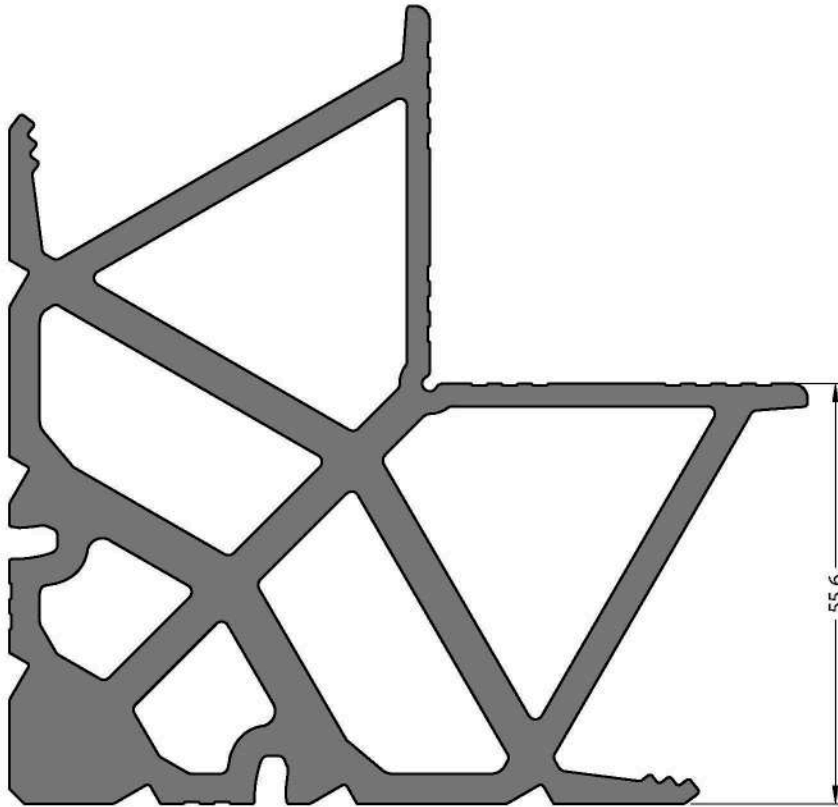

No visible surface.
Görünen yüzeyi yoktur.

CODE / KOD

09-113-00

**THEORETICAL
WEIGHT kg/m**

TEORİK AĞIRLIK kg/m

7.241

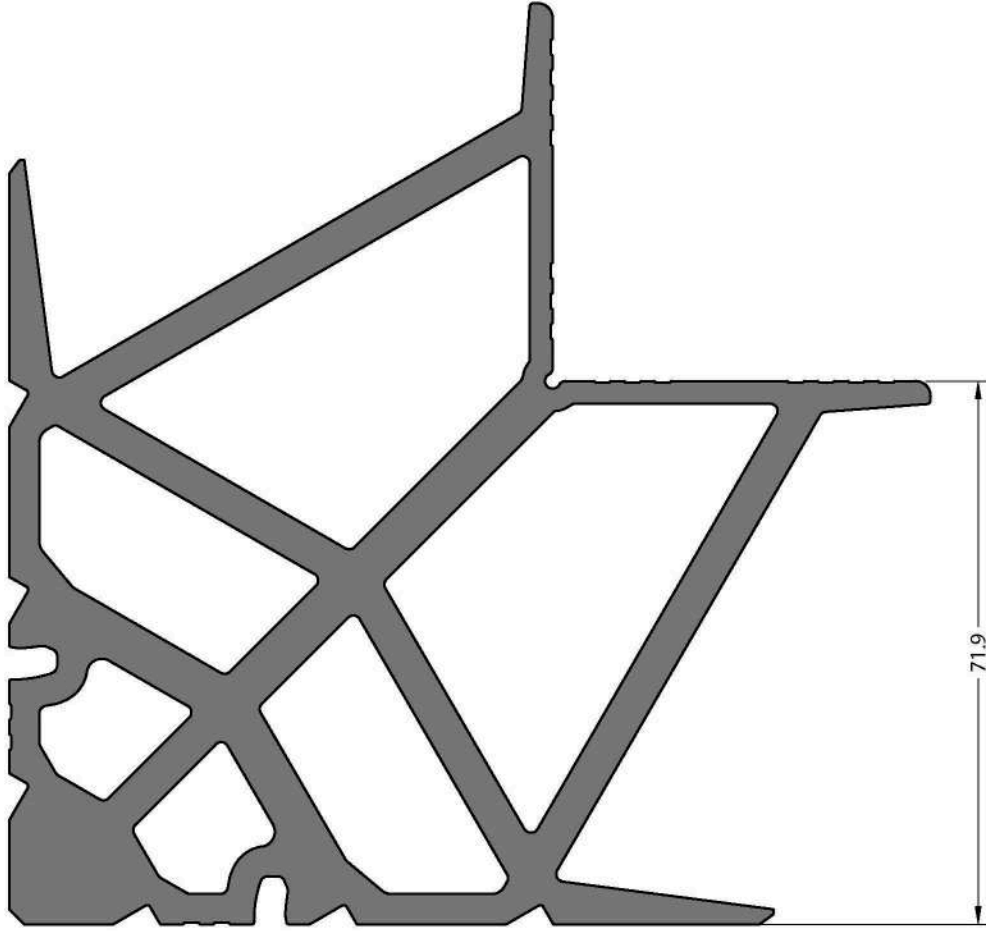

No visible surface.
Görünen yüzeyi yoktur.

CODE / KOD

09-114-00

**THEORETICAL
WEIGHT kg/m**

TEORİK AĞIRLIK kg/m

8.744

For frame and mullion profiles.
Kasa ve orta kayıt için.

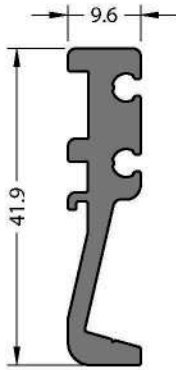

No visible surface.
Görünen yüzeyi yoktur.

CODE / KOD

09-901-00

**THEORETICAL
WEIGHT kg/m**

TEORİK AĞIRLIK kg/m

0.582

For sash profiles.
Kanat için.

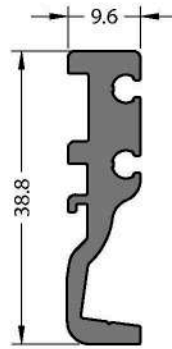

No visible surface.
Görünen yüzeyi yoktur.

CODE / KOD

09-902-00

**THEORETICAL
WEIGHT kg/m**

TEORİK AĞIRLIK kg/m

0.552

For all profiles.
Tümü için.

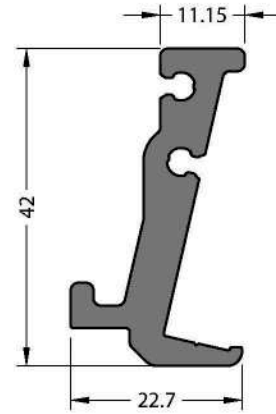

No visible surface.
Görünen yüzeyi yoktur.

CODE / KOD

09-903-00

**THEORETICAL
WEIGHT kg/m**

TEORİK AĞIRLIK kg/m

0.856

58T

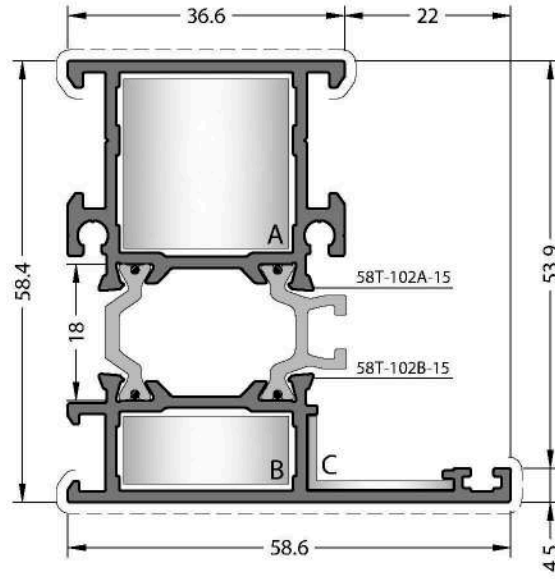

PROFILES / PROFİLLER
1.5 mm



CODE / KOD
58T-102-15

THEORETICAL WEIGHT kg/m
TEORİK AĞIRLIK kg/m
1.352

CORNER JOINTS
KÖŞE BAĞLANTILAR



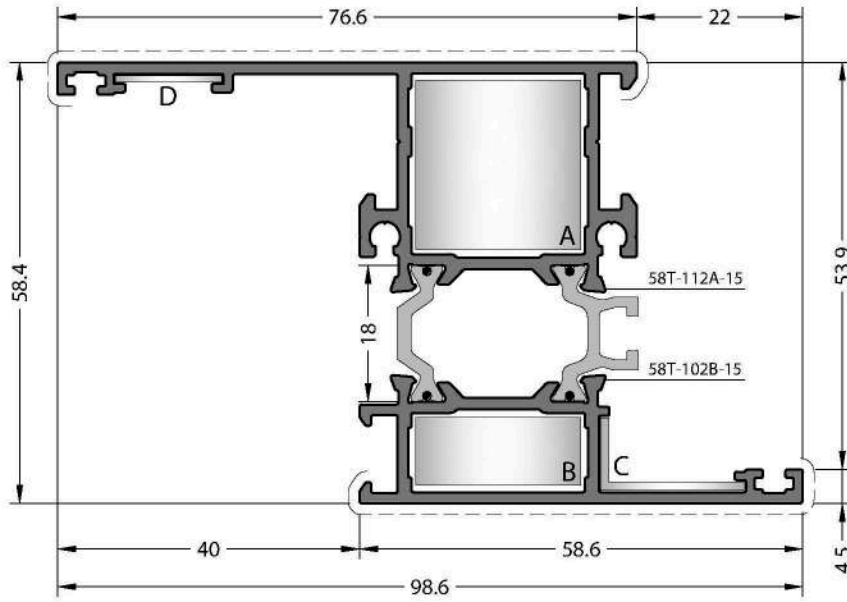

-  **A** CC-103-23.4
-  **B** CC-103-10.0
-  **C** EM58-21



CODE / KOD
58T-112-15

THEORETICAL WEIGHT kg/m
TEORİK AĞIRLIK kg/m
1.557

CORNER JOINTS
KÖŞE BAĞLANTILAR



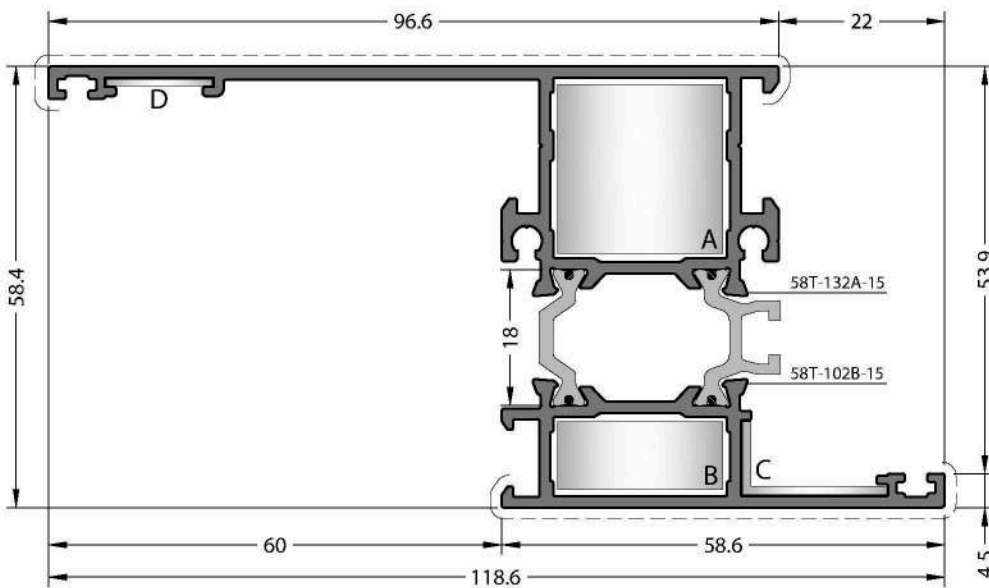

-  **A** CC-103-23.4
-  **B** CC-103-10.0
-  **C** EM58-21
-  **D** MK-20.1



CODE / KOD
58T-132-15

THEORETICAL WEIGHT kg/m
TEORİK AĞIRLIK kg/m
1.661

CORNER JOINTS
KÖŞE BAĞLANTILAR

-  **A** CC-103-23.4
-  **B** CC-103-10.0
-  **C** EM58-21
-  **D** MK-20.1

Just use for doors. / Sadece kapı için kullanılır.

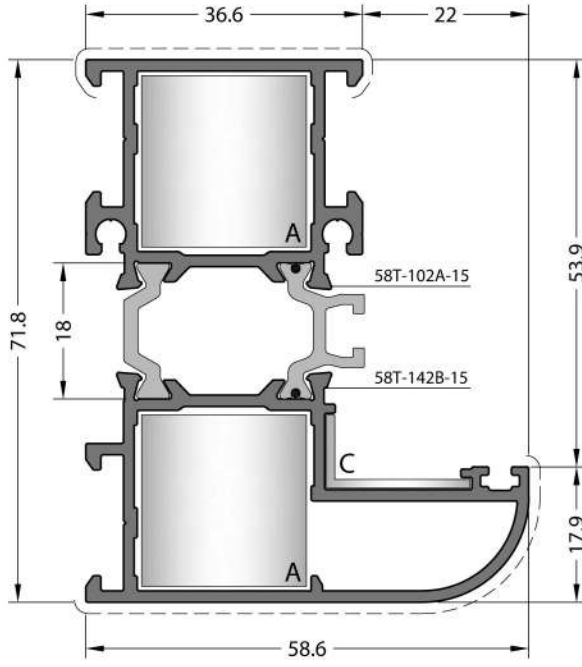

CODE / KOD

58T-142-15

THEORETICAL WEIGHT kg/m

TEORİK AĞIRLIK kg/m

1.565

CORNER JOINTS

KÖŞE BAĞLANTILAR



A CC-103-23.4



C EM58-21

JUST FOR FRAME USE ONLY!
SADECE KASA KULLANIMI İÇİNDİR!

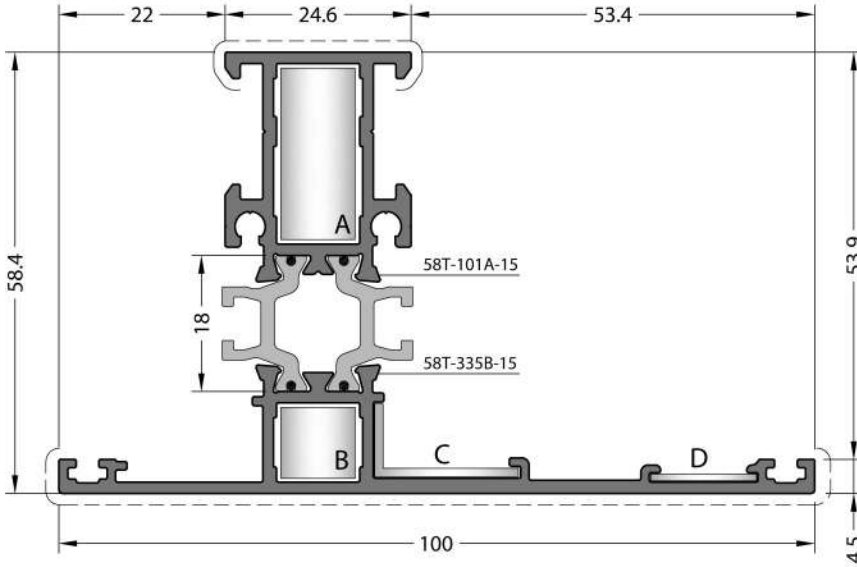

CODE / KOD

58T-335-15

THEORETICAL WEIGHT kg/m

TEORİK AĞIRLIK kg/m

1.450

CORNER JOINTS

KÖŞE BAĞLANTILAR



A CC-101-23.4



B CC-101-10.0



C EM58-21



D MK-20.1

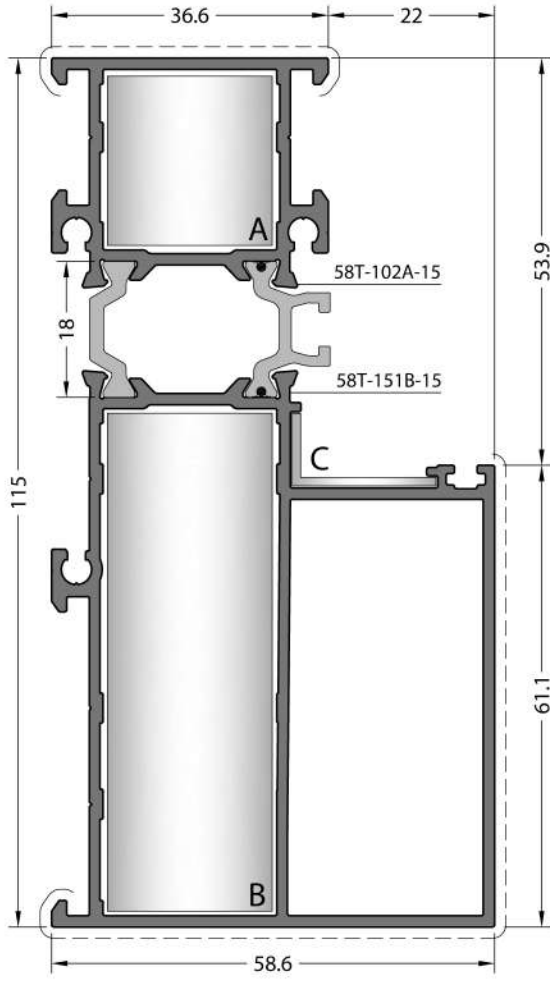

CODE / KOD
58T-151-15

THEORETICAL WEIGHT kg/m
TEORİK AĞIRLIK kg/m
2.168

CORNER JOINTS
KÖŞE BAĞLANTILAR

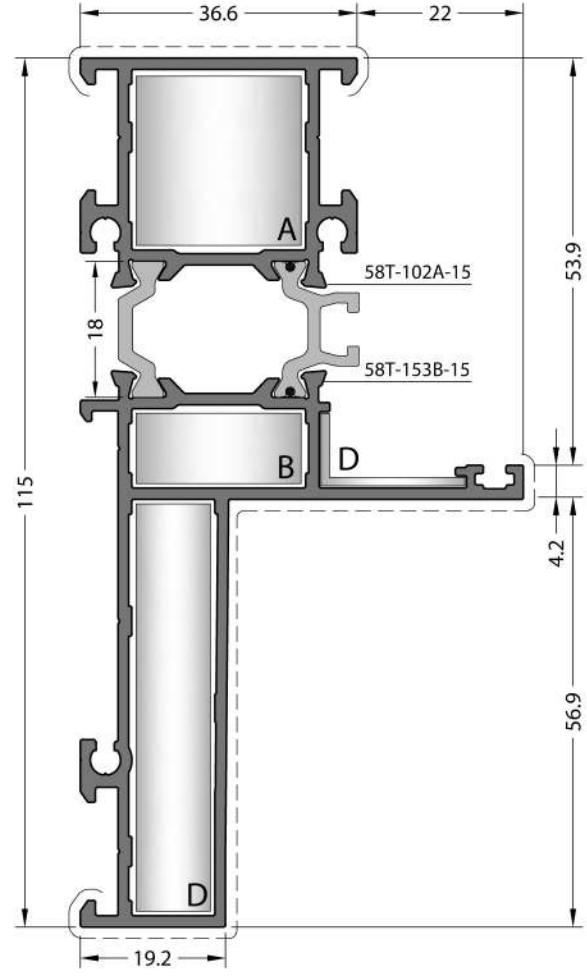
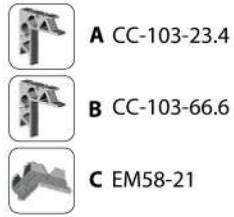

CODE / KOD
58T-153-15

THEORETICAL WEIGHT kg/m
TEORİK AĞIRLIK kg/m
1.905

CORNER JOINTS
KÖŞE BAĞLANTILAR

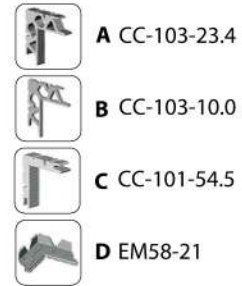

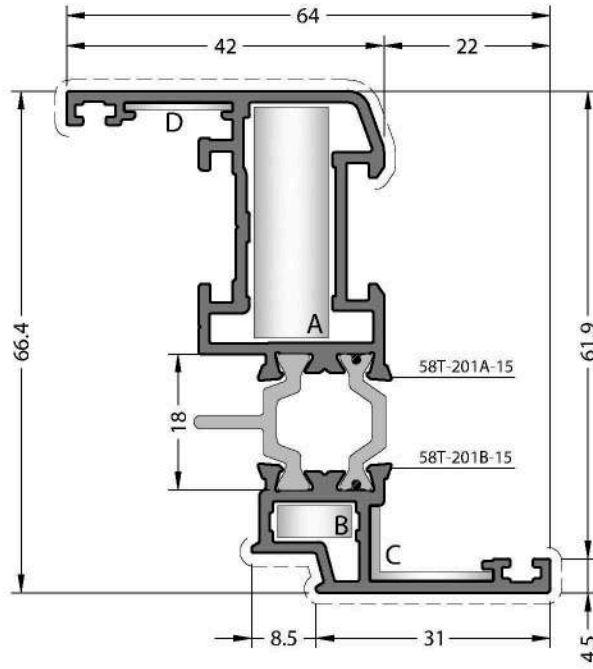

CODE / KOD

58T-201-15

THEORETICAL WEIGHT kg/m

TEORİK AĞIRLIK kg/m

1.285

CORNER JOINTS

KÖŞE BAĞLANTILAR



A CC-101-31.3



B CC-101-04.9



C EM58-22



D MK-20.1

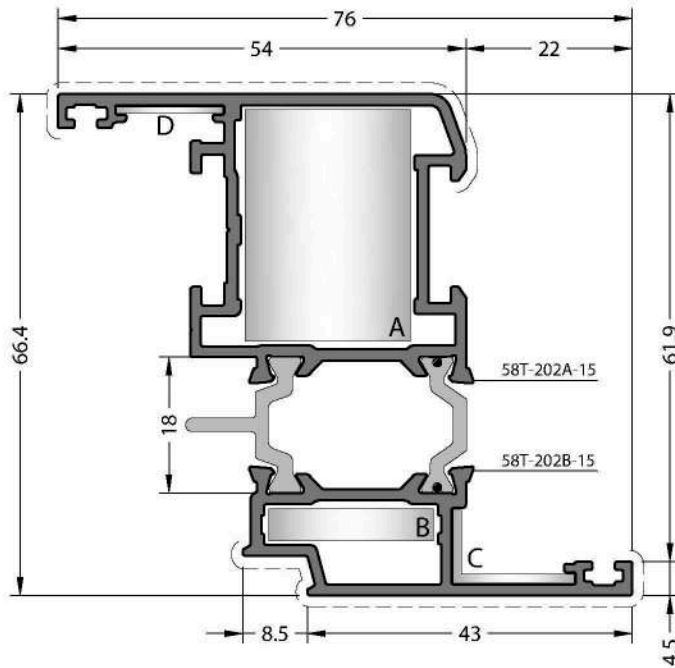

CODE / KOD

58T-202-15

THEORETICAL WEIGHT kg/m

TEORİK AĞIRLIK kg/m

1.477

CORNER JOINTS

KÖŞE BAĞLANTILAR



A CC-103-31.3



B CC-103-04.9



C EM58-22



D MK-20.1

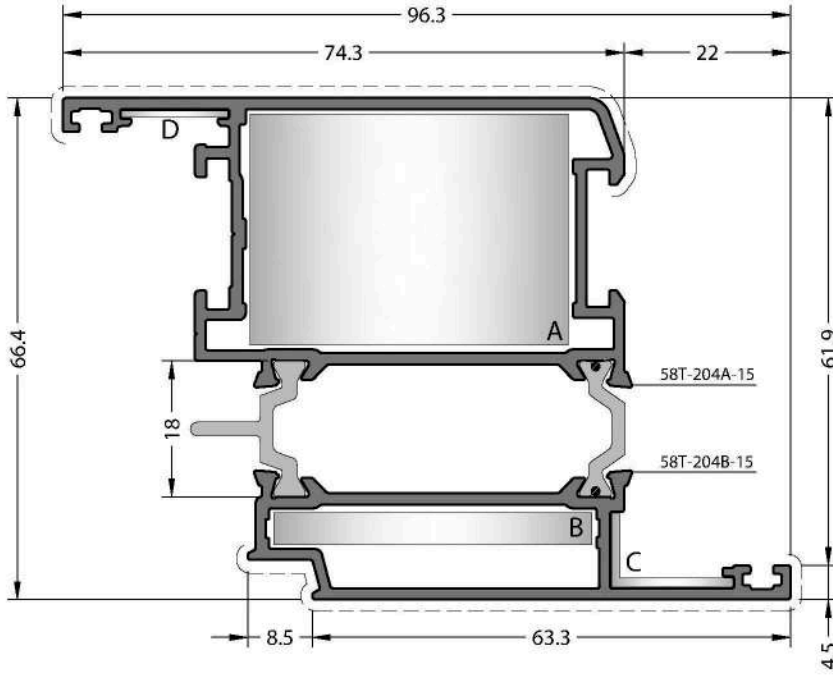

CODE / KOD

58T-204-15

THEORETICAL WEIGHT kg/m

TEORİK AĞIRLIK kg/m

1.806

CORNER JOINTS

KÖŞE BAĞLANTILAR



A CC-105-31.3



B CC-105-04.9



C EM58-22



D MK-20.1

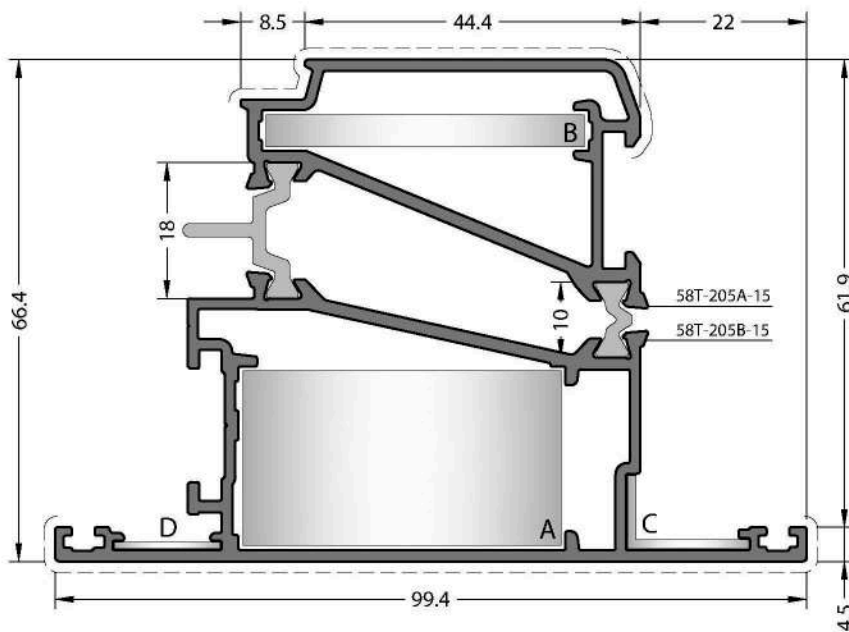

CODE / KOD

58T-205-15

THEORETICAL WEIGHT kg/m

TEORİK AĞIRLIK kg/m

1.963

CORNER JOINTS

KÖŞE BAĞLANTILAR



A CC-105-23.8



B CC-105-04.9



C EM58-22



D MK-20.1

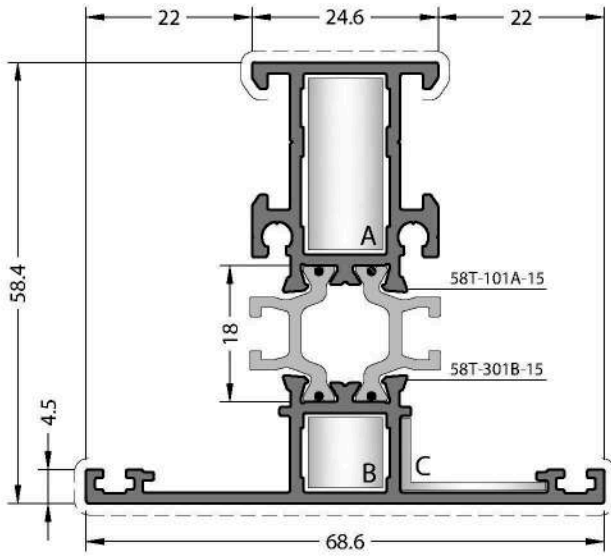

CODE / KOD

58T-301-15

THEORETICAL WEIGHT kg/m

TEORİK AĞIRLIK kg/m

1.262

T JUNCTION

ÇEKTİRME BAĞLANTI



A CC-903-10.5



FOR FRAME / KASA İÇİN

B CC-901-10.5



FOR SASH / KANAT İÇİN

B CC-902-10.5

CORNER JOINTS

KÖŞE BAĞLANTILAR



A CC-101-23.4



B CC-101-10.0



C EM58-21

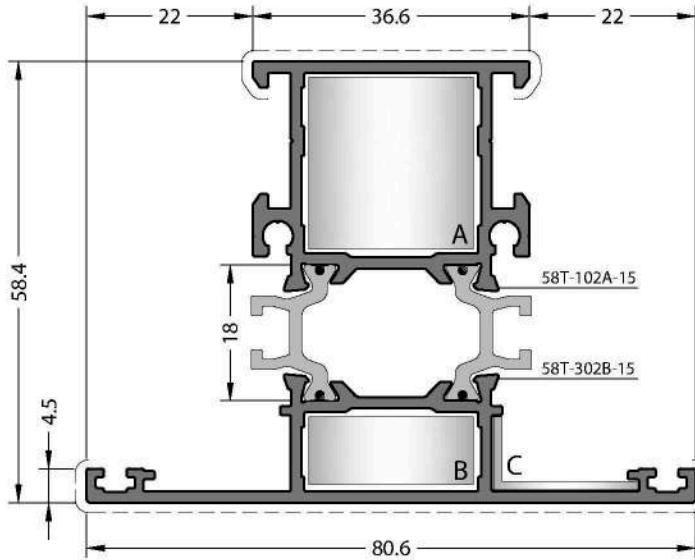

CODE / KOD

58T-302-15

THEORETICAL WEIGHT kg/m

TEORİK AĞIRLIK kg/m

1.470

T JUNCTION

ÇEKTİRME BAĞLANTI



A CC-903-22.5



FOR FRAME / KASA İÇİN

B CC-901-22.5



FOR SASH / KANAT İÇİN

B CC-902-22.5

CORNER JOINTS

KÖŞE BAĞLANTILAR



A CC-103-23.4



B CC-103-10.0



C EM58-21

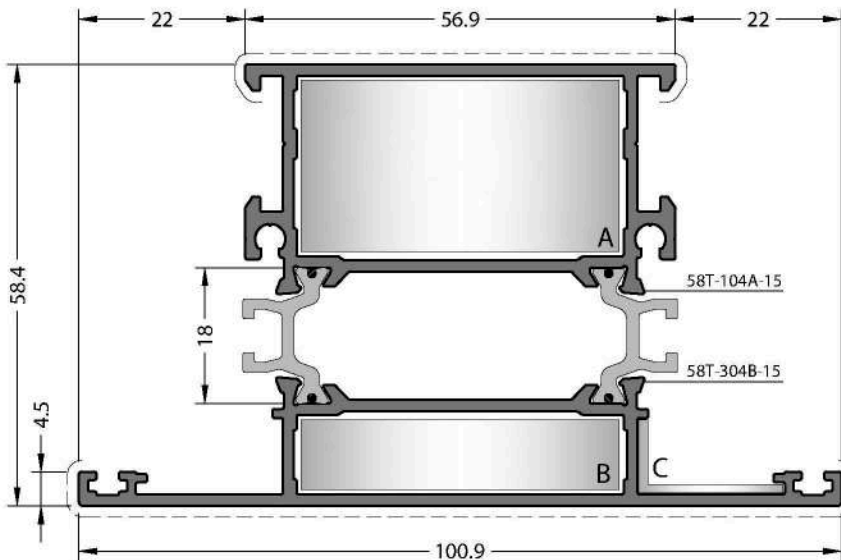

CODE / KOD

58T-304-15

THEORETICAL WEIGHT kg/m

TEORİK AĞIRLIK kg/m

1.800

T JUNCTION

ÇEKTİRME BAĞLANTI



A CC-903-42.8



FOR FRAME / KASA İÇİN

B CC-901-42.8



FOR SASH / KANAT İÇİN

B CC-902-42.8

CORNER JOINTS

KÖŞE BAĞLANTILAR



A CC-105-23.4



B CC-105-10.0



C EM58-21

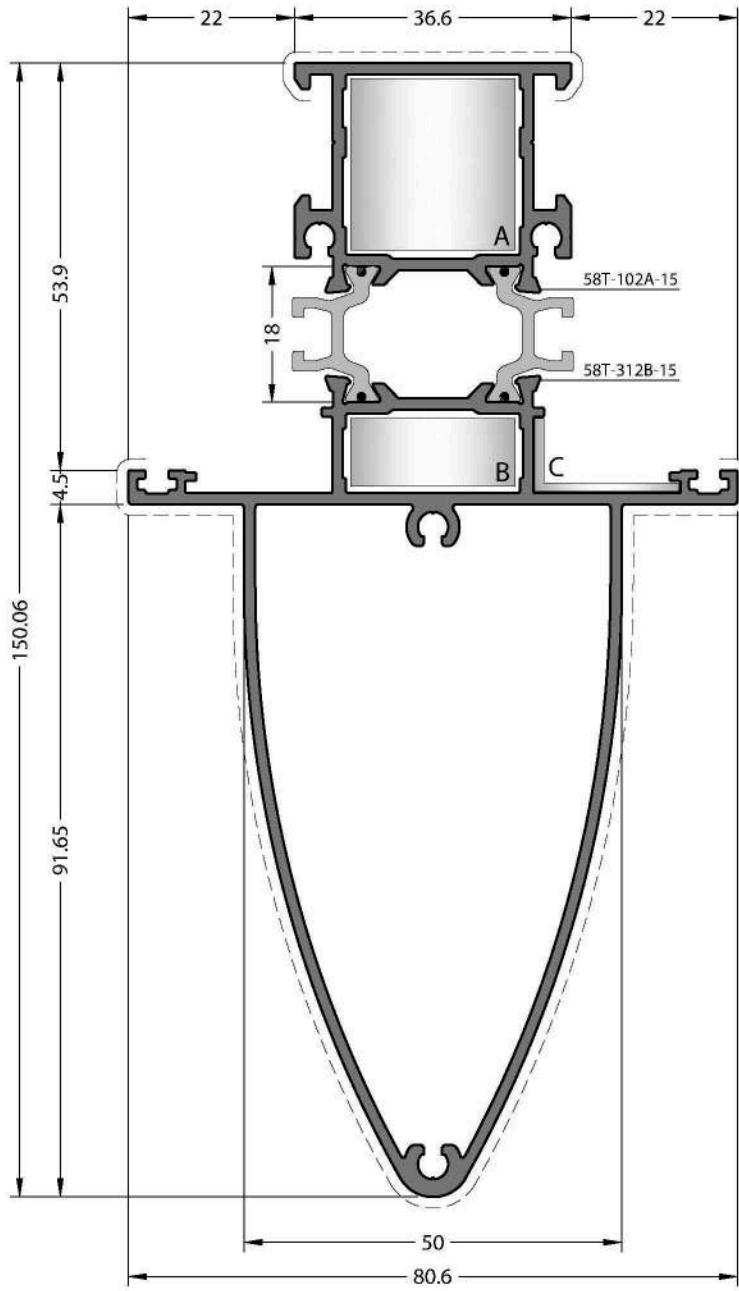

CODE / KOD

58T-312-15

THEORETICAL WEIGHT kg/m

TEORİK AĞIRLIK kg/m

2.360

T JUNCTION

ÇEKTİRME BAĞLANTI



A CC-903-22.5



FOR FRAME / KASA İÇİN

B CC-901-22.5



FOR SASH / KANAT İÇİN

B CC-902-22.5

CORNER JOINTS

KÖŞE BAĞLANTILAR



A CC-103-23.4



B CC-103-10.0



C EM58-21

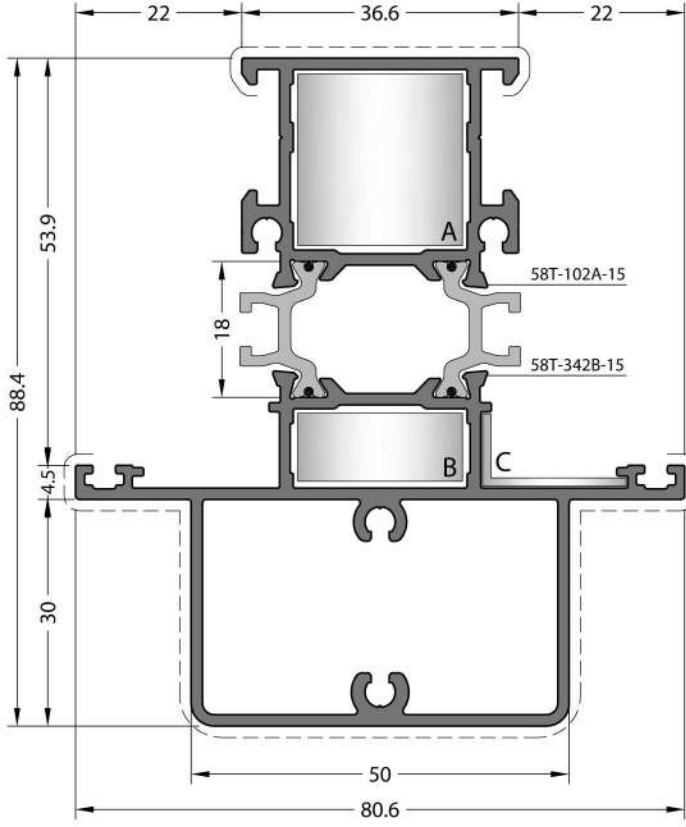

CODE / KOD

58T-342-15

THEORETICAL WEIGHT kg/m

TEORİK AĞIRLIK kg/m

2.017

T JUNCTION

ÇEKTİRME BAĞLANTI



A CC-903-22.5



FOR FRAME / KASA İÇİN

B CC-901-22.5



FOR SASH / KANAT İÇİN

B CC-902-22.5

CORNER JOINTS

KÖŞE BAĞLANTILAR



A CC-103-23.4



B CC-103-10.0



C EM58-21

58T

PROFILES / PROFİLLER
2 mm

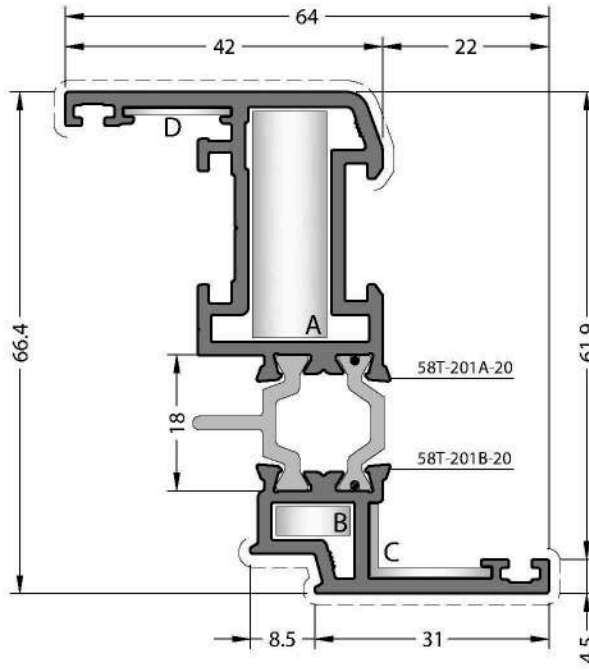

CODE / KOD

58T-201-20

THEORETICAL WEIGHT kg/m

TEORİK AĞIRLIK kg/m

1.461

CORNER JOINTS

KÖŞE BAĞLANTILAR



A CC-101-30.8



B CC-101-04.6



C EM58-22



D MK-20.1

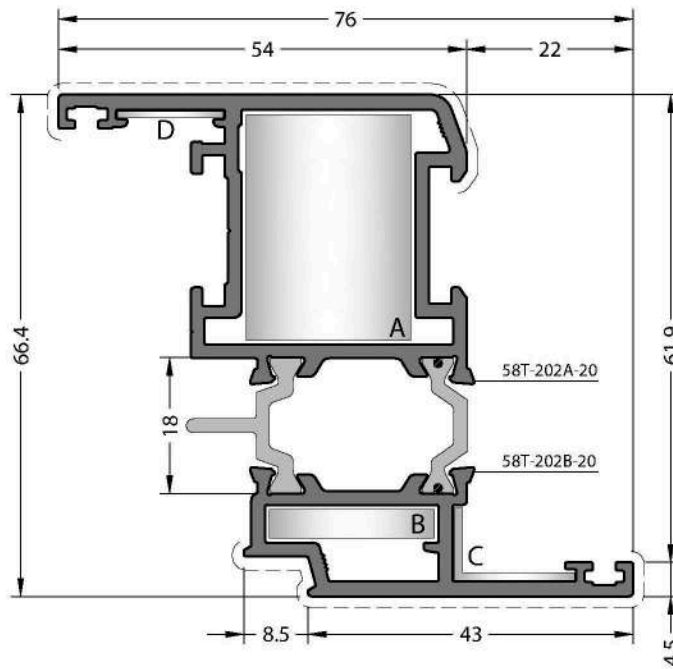

CODE / KOD

58T-202-20

THEORETICAL WEIGHT kg/m

TEORİK AĞIRLIK kg/m

1.722

CORNER JOINTS

KÖŞE BAĞLANTILAR



A CC-103-30.8



B CC-103-04.6



C EM58-22





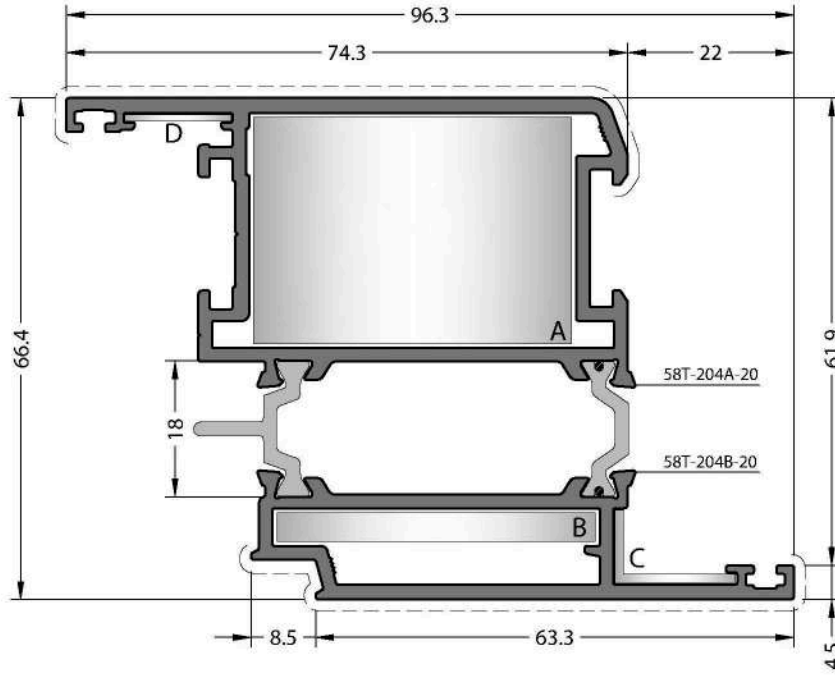

D MK-20.1



CODE / KOD
58T-204-20

THEORETICAL WEIGHT kg/m
TEORİK AĞIRLIK kg/m
2.138

CORNER JOINTS
KÖŞE BAĞLANTILAR



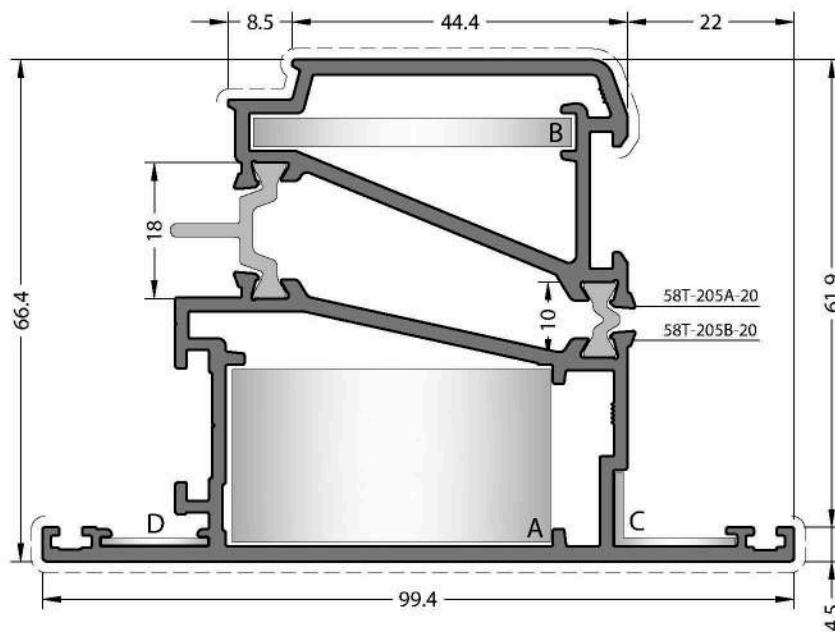

-  **A** CC-105-30.8
-  **B** CC-105-04.6
-  **C** EM58-22
-  **D** MK-20.1



CODE / KOD
58T-205-20

THEORETICAL WEIGHT kg/m
TEORİK AĞIRLIK kg/m
2.308

CORNER JOINTS
KÖŞE BAĞLANTILAR

-  **A** CC-105-23.6
-  **B** CC-105-04.6
-  **C** EM58-22
-  **D** MK-20.1

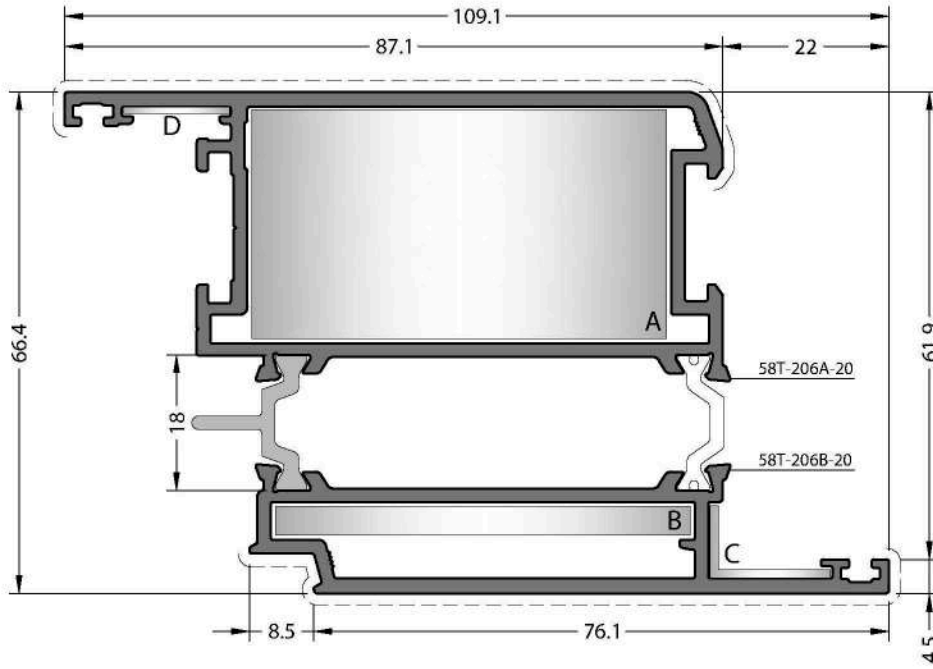

CODE / KOD

58T-206-20

THEORETICAL WEIGHT kg/m

TEORİK AĞIRLIK kg/m

2.388

CORNER JOINTS

KÖŞE BAĞLANTILAR



A CC-113-30.8



B CC-113-04.5



C EM58-22



D MK-20.1

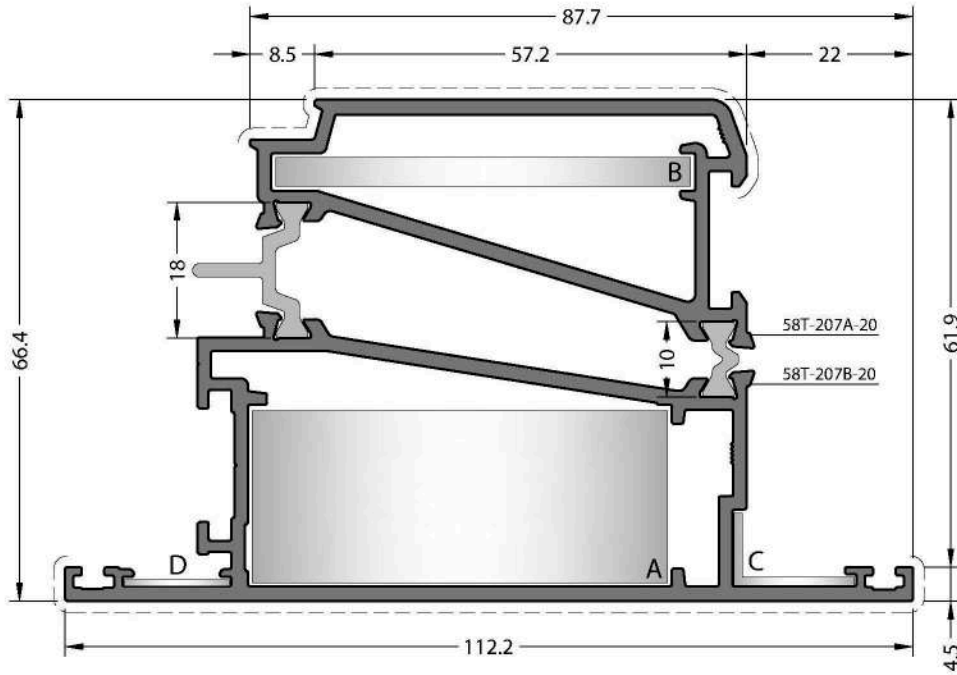

CODE / KOD

58T-207-20

THEORETICAL WEIGHT kg/m

TEORİK AĞIRLIK kg/m

2.581

CORNER JOINTS

KÖŞE BAĞLANTILAR



A CC-113-23.5



B CC-113-04.5



C EM58-22



D MK-20.1

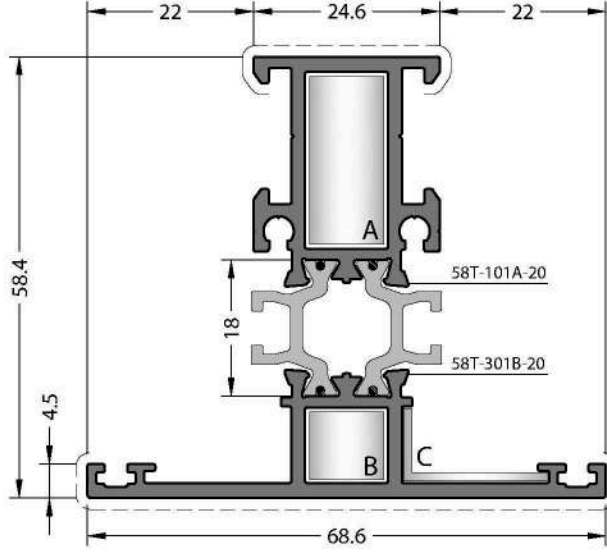

CODE / KOD

58T-301-20

THEORETICAL WEIGHT kg/m

TEORİK AĞIRLIK kg/m

1.394

T JUNCTION

ÇEKTİRME BAĞLANTI



A CC-903-10.5

FOR FRAME / KASA İÇİN



B CC-901-10.5

FOR SASH / KANAT İÇİN



B CC-902-10.5

CORNER JOINTS

KÖŞE BAĞLANTILAR



A CC-101-23.0



B CC-101-09.6



C EM58-21

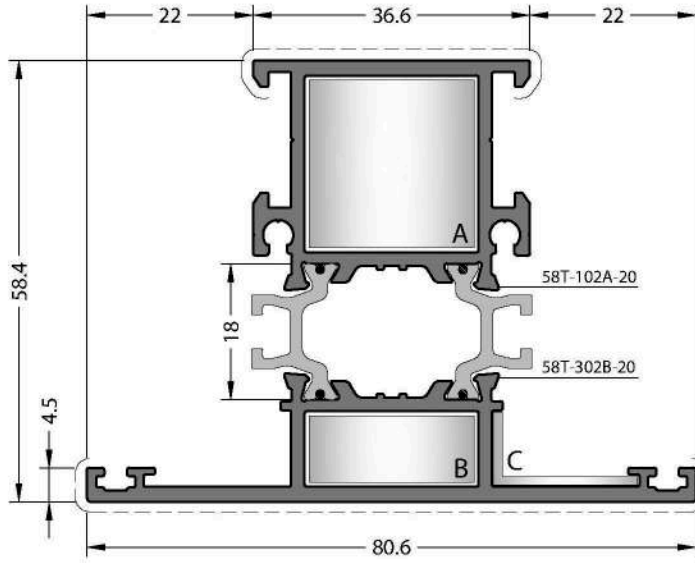

CODE / KOD

58T-302-20

THEORETICAL WEIGHT kg/m

TEORİK AĞIRLIK kg/m

1.662

T JUNCTION

ÇEKTİRME BAĞLANTI



A CC-903-22.5

FOR FRAME / KASA İÇİN



B CC-901-22.5

FOR SASH / KANAT İÇİN



B CC-902-22.5

CORNER JOINTS

KÖŞE BAĞLANTILAR



A CC-103-23.0



B CC-103-09.6



C EM58-21

58T

PERIMETRIC PROFILES / PERİMETRİK PROFİLLER

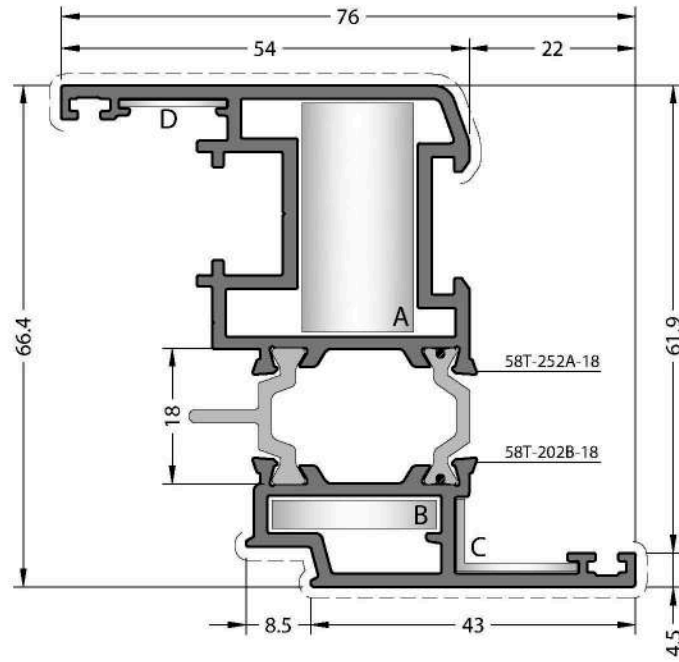

CODE / KOD

58T-252-18

THEORETICAL WEIGHT kg/m

TEORİK AĞIRLIK kg/m

1.713

CORNER JOINTS

KÖŞE BAĞLANTILAR



A CC-110-31.0



B CC-103-04.6



C EM58-22



D MK-20.1

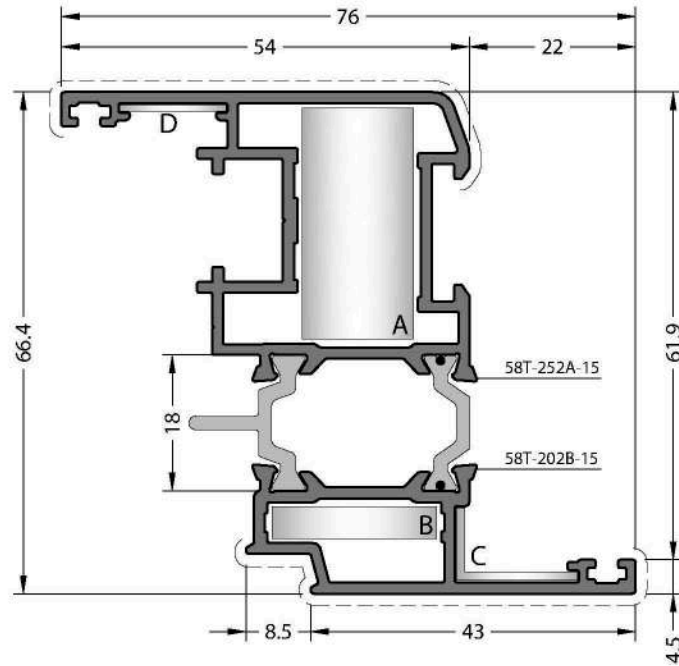

CODE / KOD

58T-252-15

THEORETICAL WEIGHT kg/m

TEORİK AĞIRLIK kg/m

1.515

CORNER JOINTS

KÖŞE BAĞLANTILAR



A CC-110-31.3



B CC-103-04.9



C EM58-22





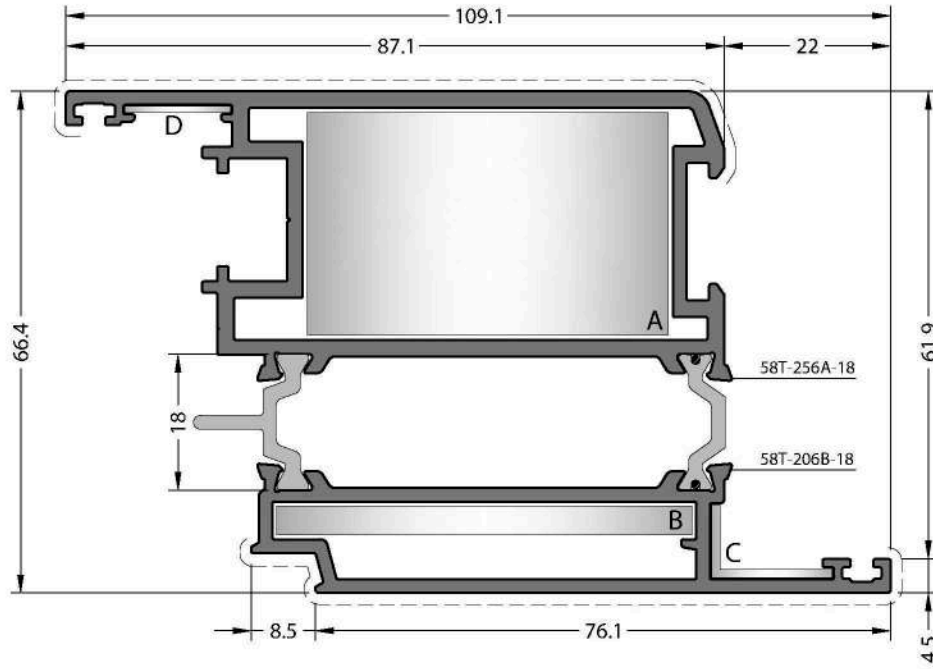

D MK-20.1



CODE / KOD
58T-256-18

THEORETICAL WEIGHT kg/m
TEORİK AĞIRLIK kg/m
2.548

CORNER JOINTS
KÖŞE BAĞLANTILAR

-  **A** CC-117-30.2
-  **B** CC-113-04.5
-  **C** EM58-22
-  **D** MK-20.1

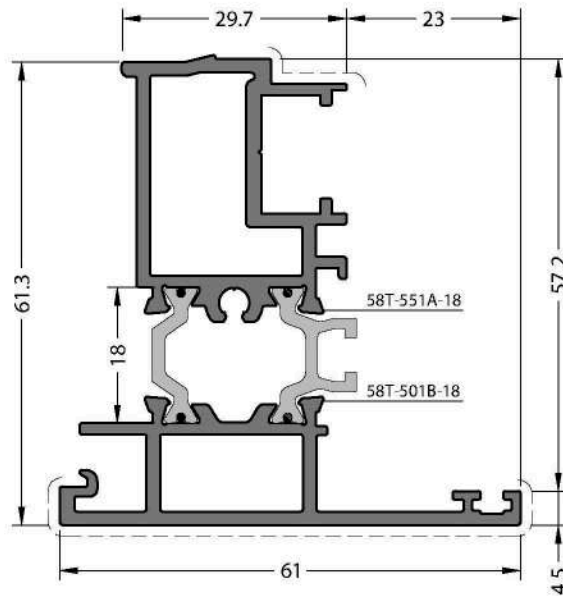

CODE / KOD
58T-551-18

THEORETICAL WEIGHT kg/m
TEORİK AĞIRLIK kg/m
1.509

ADAPTER CAP
ADAPTÖR KAPAĞI

-  **EM58T-551**

58T

HIDDEN SASH PROFILES / GİZLİ KANAT PROFİLLERİ

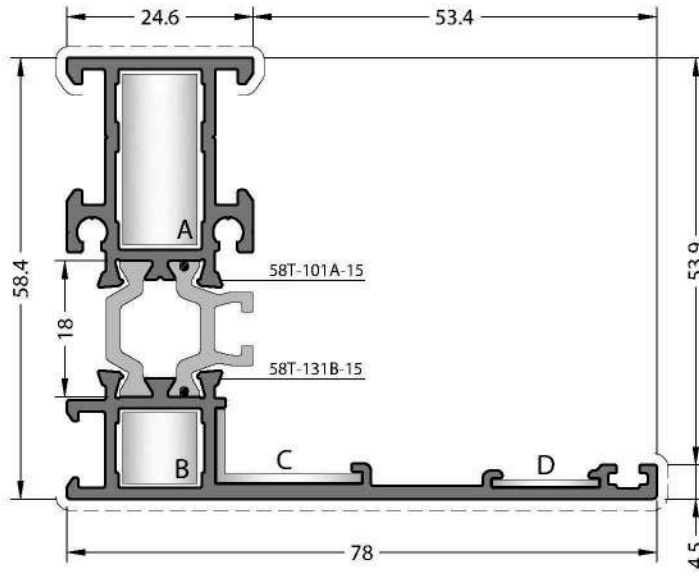

CODE / KOD

58T-131-15

THEORETICAL WEIGHT kg/m

TEORİK AĞIRLIK kg/m

1.333

CORNER JOINTS

KÖŞE BAĞLANTILAR



A CC-101-23.4



B CC-101-10.0



C EM58-21



D MK-20.1

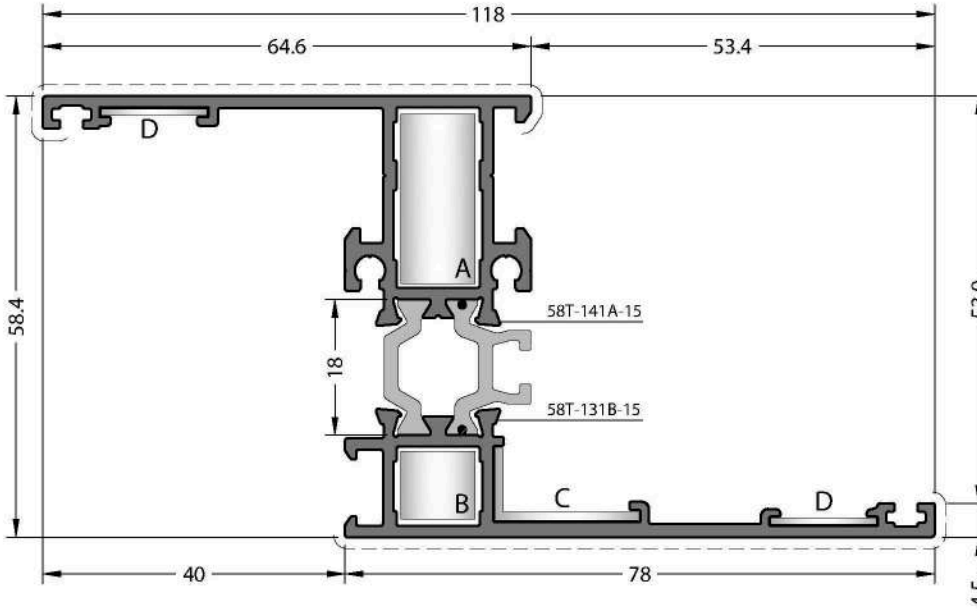

CODE / KOD

58T-141-15

THEORETICAL WEIGHT kg/m

TEORİK AĞIRLIK kg/m

1.533

CORNER JOINTS

KÖŞE BAĞLANTILAR



A CC-101-23.4



B CC-101-10.0



C EM58-21



D MK-20.1

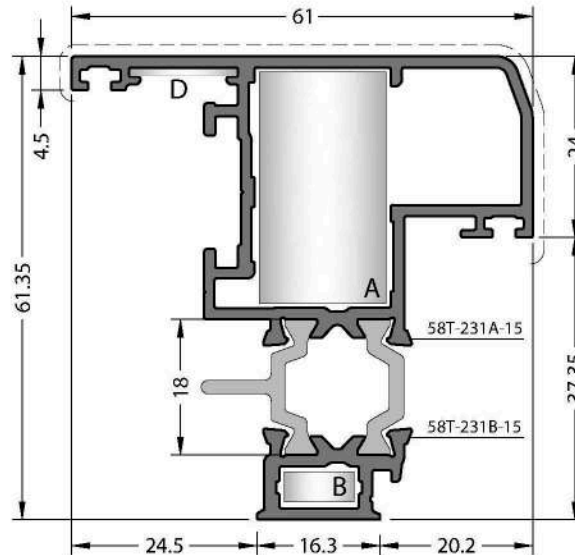

CODE / KOD

58T-231-15

THEORETICAL WEIGHT kg/m

TEORİK AĞIRLIK kg/m

1.283

CORNER JOINTS

KÖŞE BAĞLANTILAR



A CC-122-31.3



B CC-121-05.0



D MK-20.1



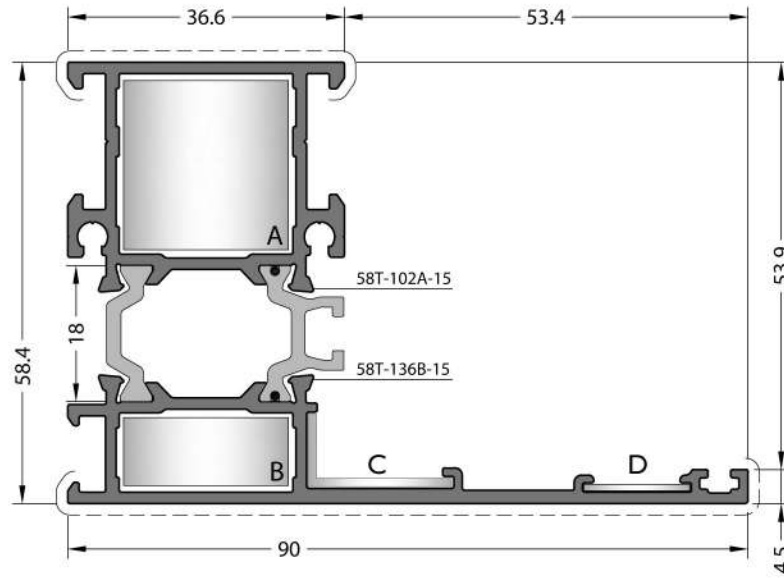

58T-231B-15 Black Anodising. / Siyah Eloksal.
No visible surface. / Görünen yüzeyi yoktur.



CODE / KOD
58T-136-15

THEORETICAL WEIGHT kg/m
TEORİK AĞIRLIK kg/m
1.540

CORNER JOINTS
KÖŞE BAĞLANTILAR



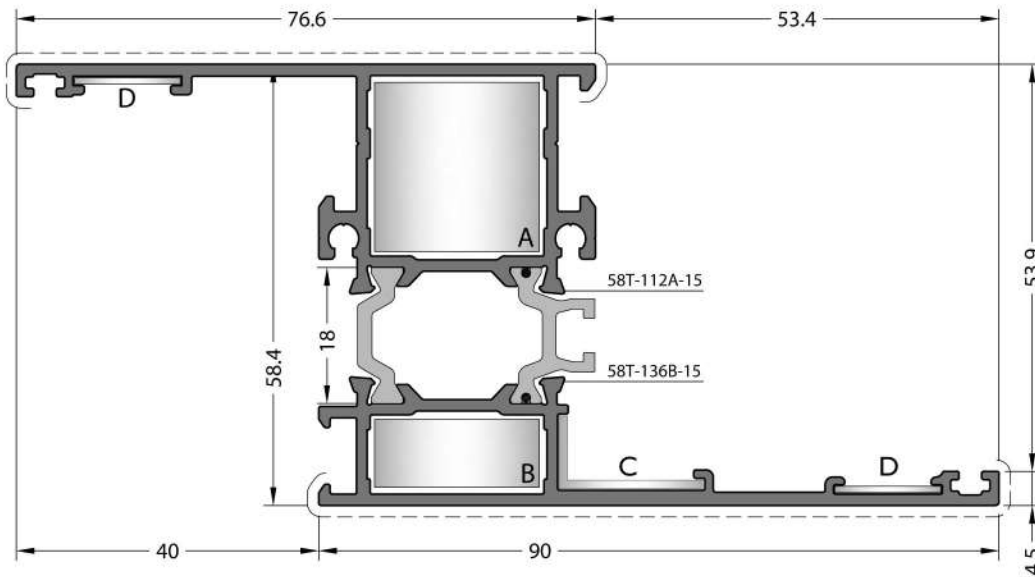

-  **A** CC-103-23.4
-  **B** CC-103-10.0
-  **C** EM58-21
-  **D** MK-20.1



CODE / KOD
58T-137-15

THEORETICAL WEIGHT kg/m
TEORİK AĞIRLIK kg/m
1.745

CORNER JOINTS
KÖŞE BAĞLANTILAR

-  **A** CC-103-23.4
-  **B** CC-103-10.0
-  **C** EM58-21
-  **D** MK-20.1

Usable with just one side sash.
Sadece kanat tek tarafta uygulanabilir.

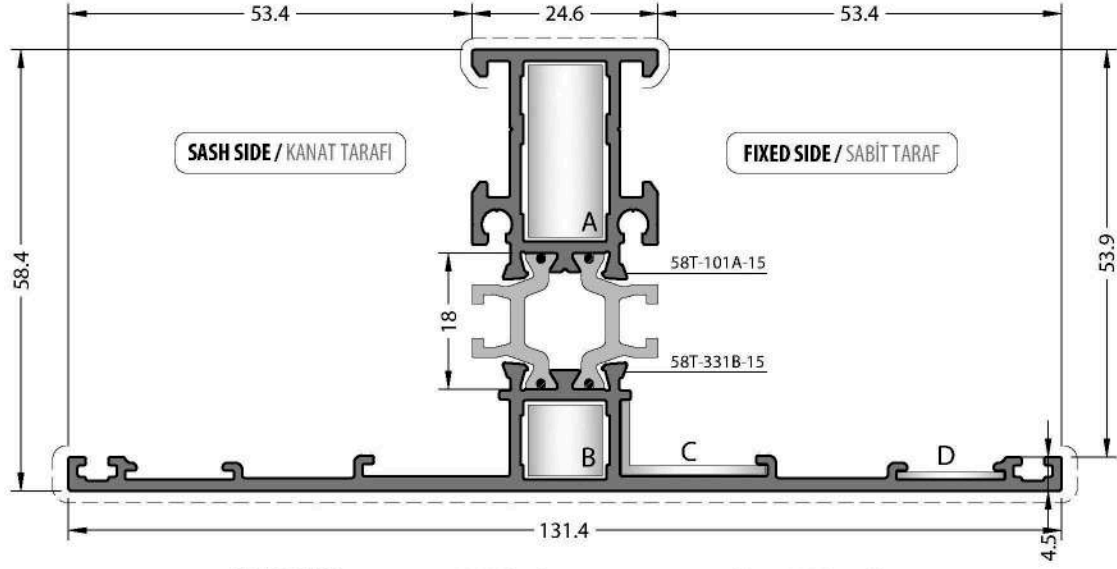

CODE / KOD

58T-331-15

THEORETICAL WEIGHT kg/m

TEORİK AĞIRLIK kg/m

1.636

T JUNCTION

ÇEKTİRME BAĞLANTI



A CC-903-10.5

FOR FRAME / KASA İÇİN



B CC-901-10.5

FOR SASH / KANAT İÇİN



B CC-902-10.5

CORNER JOINTS

KÖŞE BAĞLANTILAR



C EM58-21



D MK-20.1

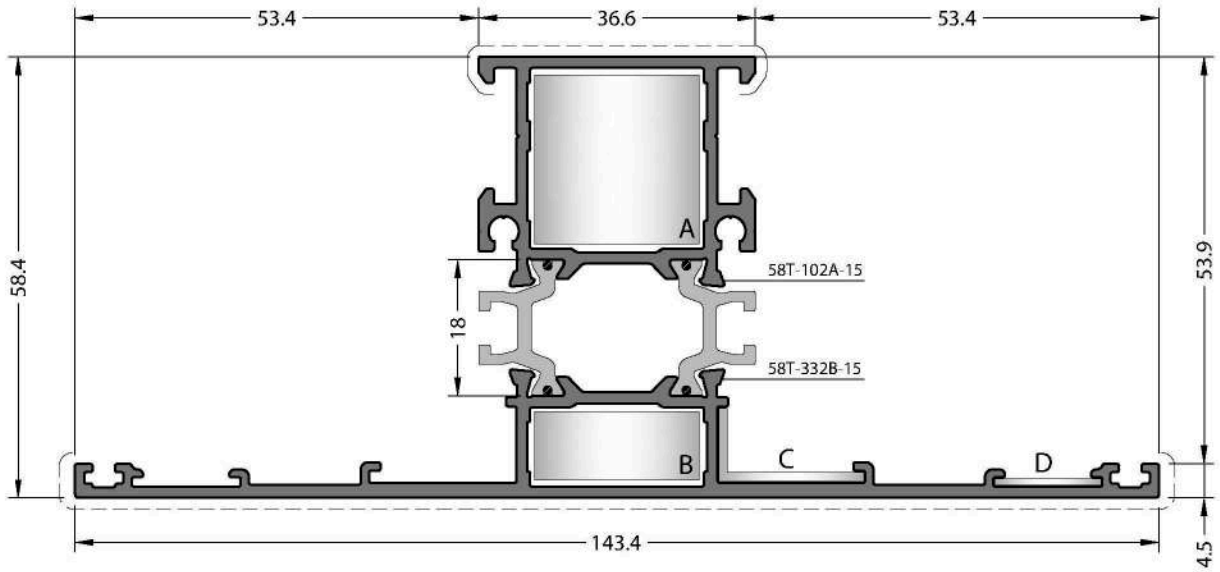

CODE / KOD

58T-332-15

THEORETICAL WEIGHT kg/m

TEORİK AĞIRLIK kg/m

1.843

T JUNCTION

ÇEKTİRME BAĞLANTI



A CC-903-22.5

FOR FRAME / KASA İÇİN



B CC-901-22.5

FOR SASH / KANAT İÇİN



B CC-902-22.5

CORNER JOINTS

KÖŞE BAĞLANTILAR



C EM58-21



D MK-20.1

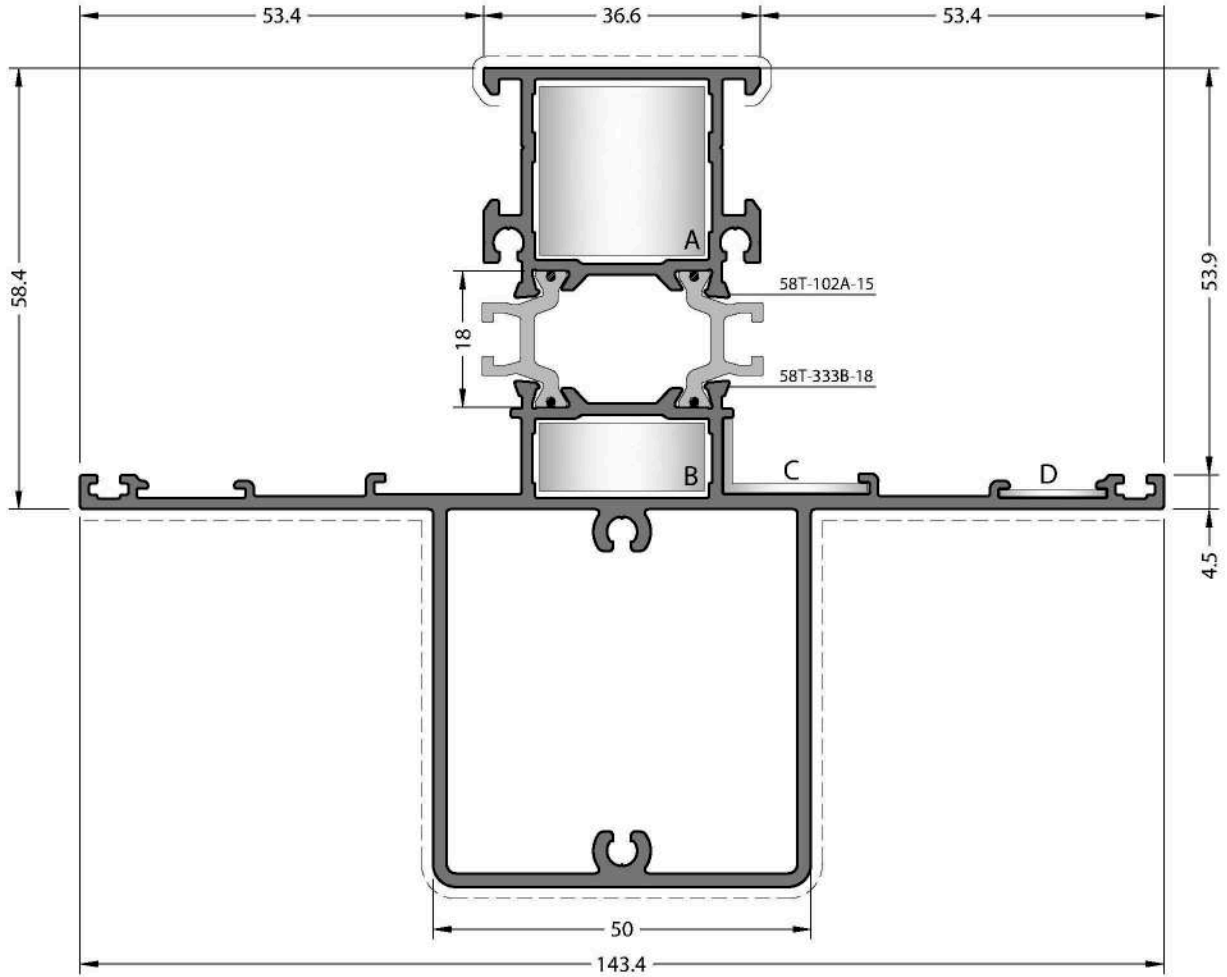

CODE / KOD
58T-333-15

THEORETICAL WEIGHT kg/m
TEORİK AĞIRLIK kg/m
2.677

T JUNCTION
ÇEKTİRME BAĞLANTI



A CC-903-22.5



FOR FRAME / KASA İÇİN

B CC-901-22.5



FOR SASH / KANAT İÇİN

B CC-902-22.5

CORNER JOINTS
KÖŞE BAĞLANTILAR



A CC-103-23.4



B CC-103-10.0



C EM58-21



D MK-20.1

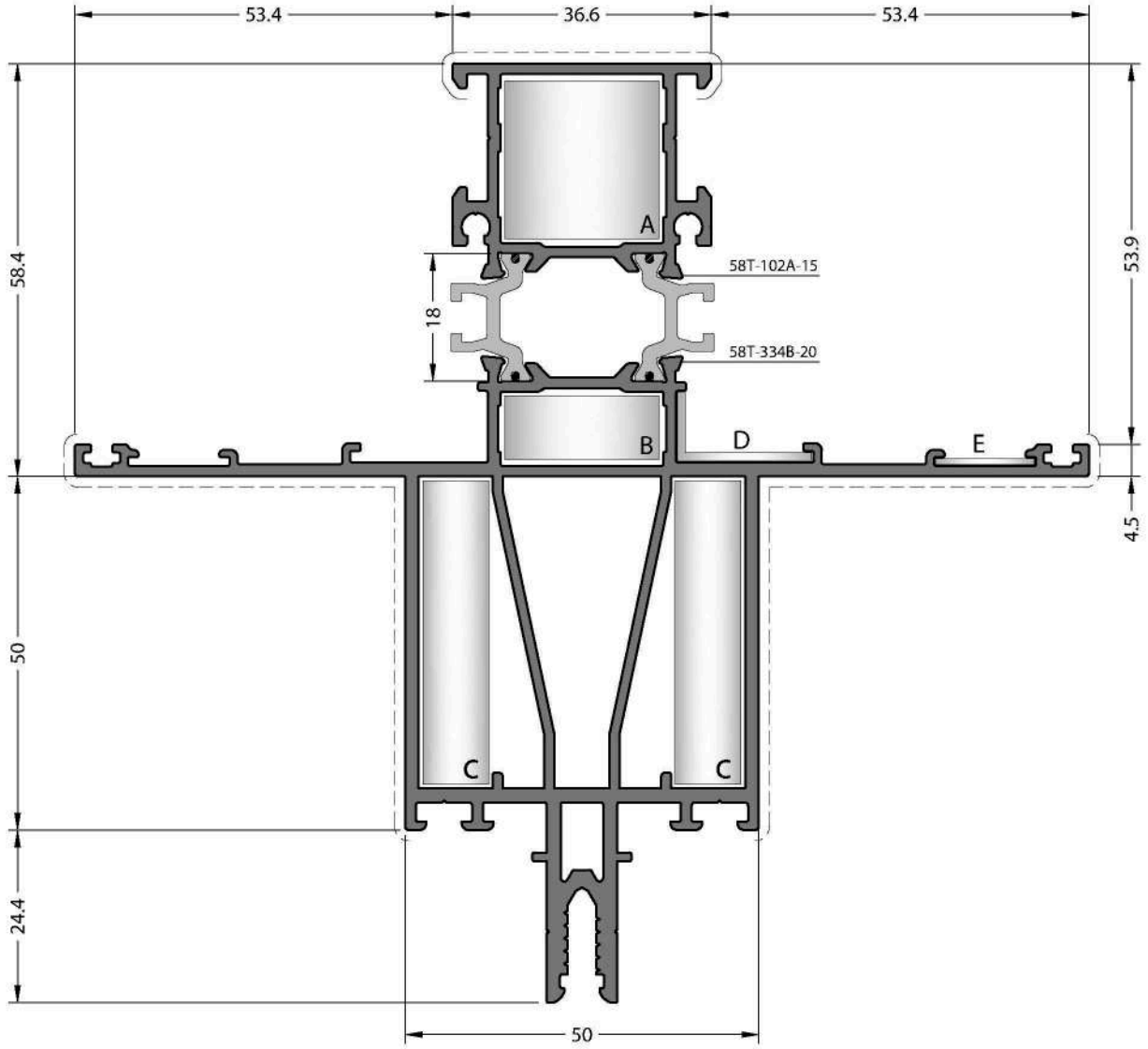

CODE / KOD
58T-334-15

THEORETICAL WEIGHT kg/m
TEORİK AĞIRLIK kg/m
3.430

T JUNCTION
ÇEKTİRME BAĞLANTI



A CC-903-22.5



FOR FRAME / KASA İÇİN

B CC-901-22.5



FOR SASH / KANAT İÇİN

B CC-902-22.5

CORNER JOINTS
KÖŞE BAĞLANTILAR



A CC-103-23.4



B CC-103-10.0



C CC-121-43.6



D EM58-21



E MK-20.1

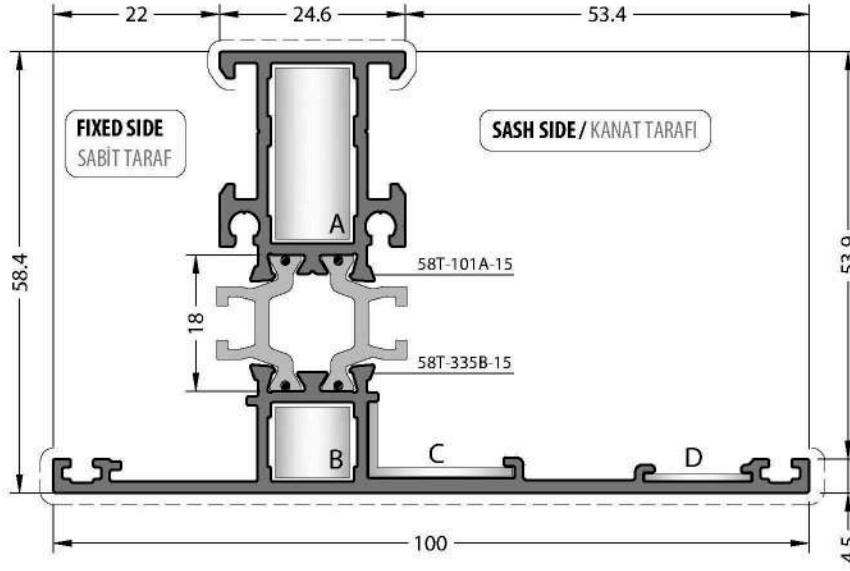

CODE / KOD
58T-335-15

THEORETICAL WEIGHT kg/m
TEORİK AĞIRLIK kg/m
1.450

T JUNCTION
ÇEKİRME BAĞLANTI

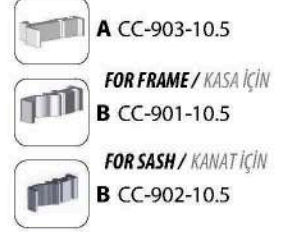

CORNER JOINTS
KÖŞE BAĞLANTILAR

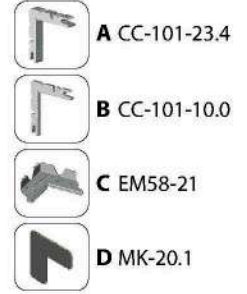

No visible surface. / Görünen yüzeyi yoktur.

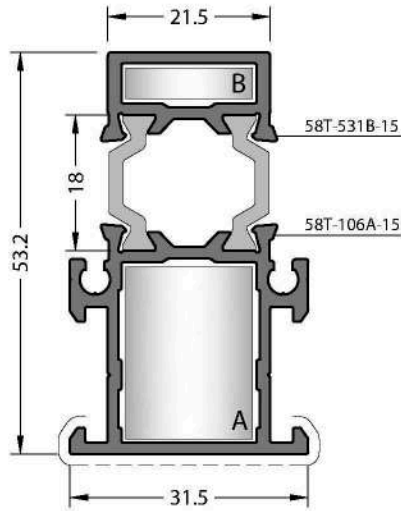

CODE / KOD
58T-531-15

THEORETICAL WEIGHT kg/m
TEORİK AĞIRLIK kg/m
1.021

CORNER JOINTS
KÖŞE BAĞLANTILAR

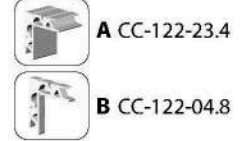

Black Anodising. / Siyah Eloksal.
No visible surface. / Görünen yüzeyi yoktur.

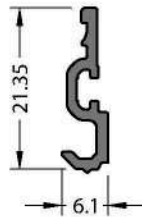

CODE / KOD
58T-831-00

THEORETICAL WEIGHT kg/m
TEORİK AĞIRLIK kg/m
0.129

58T

DETAILS / DETAYLAR

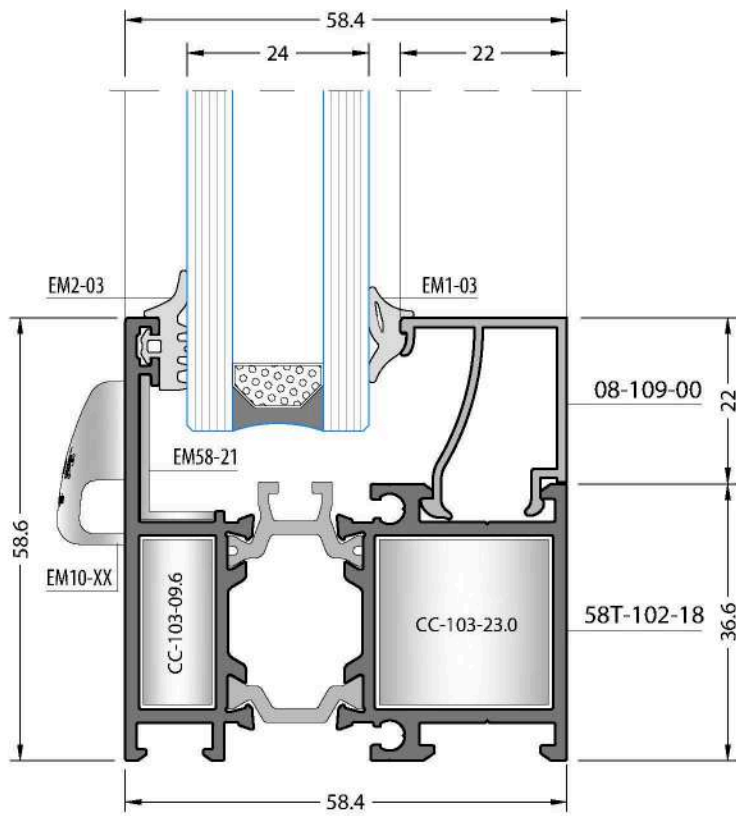
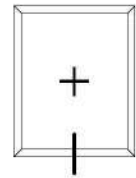
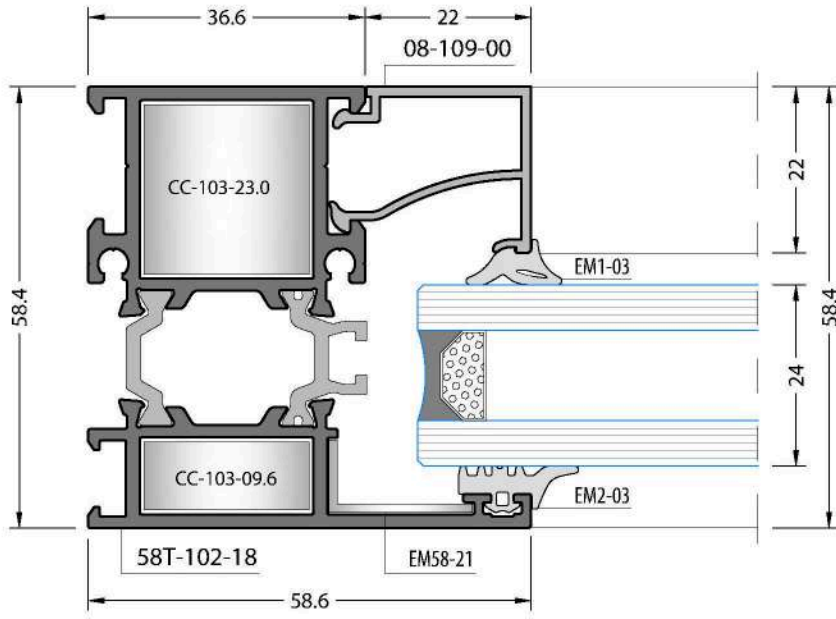
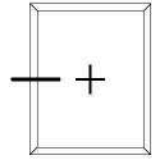

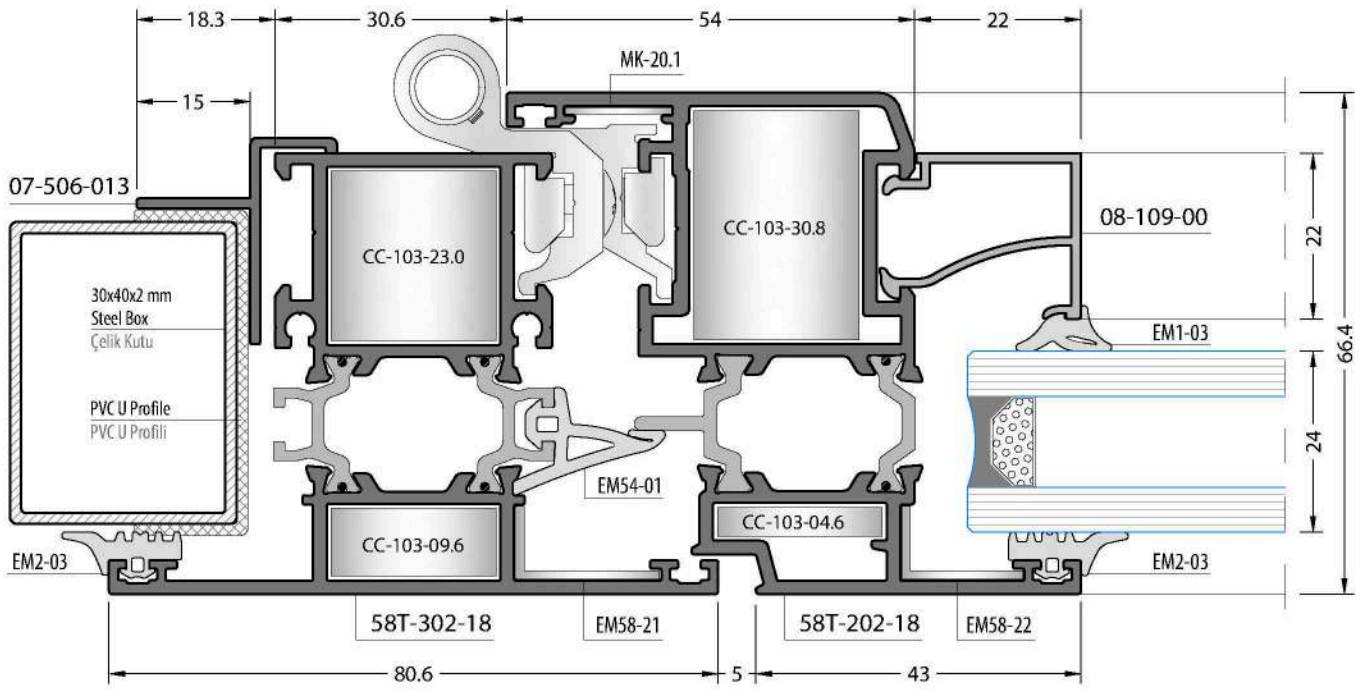
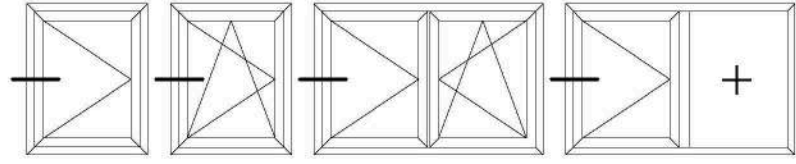

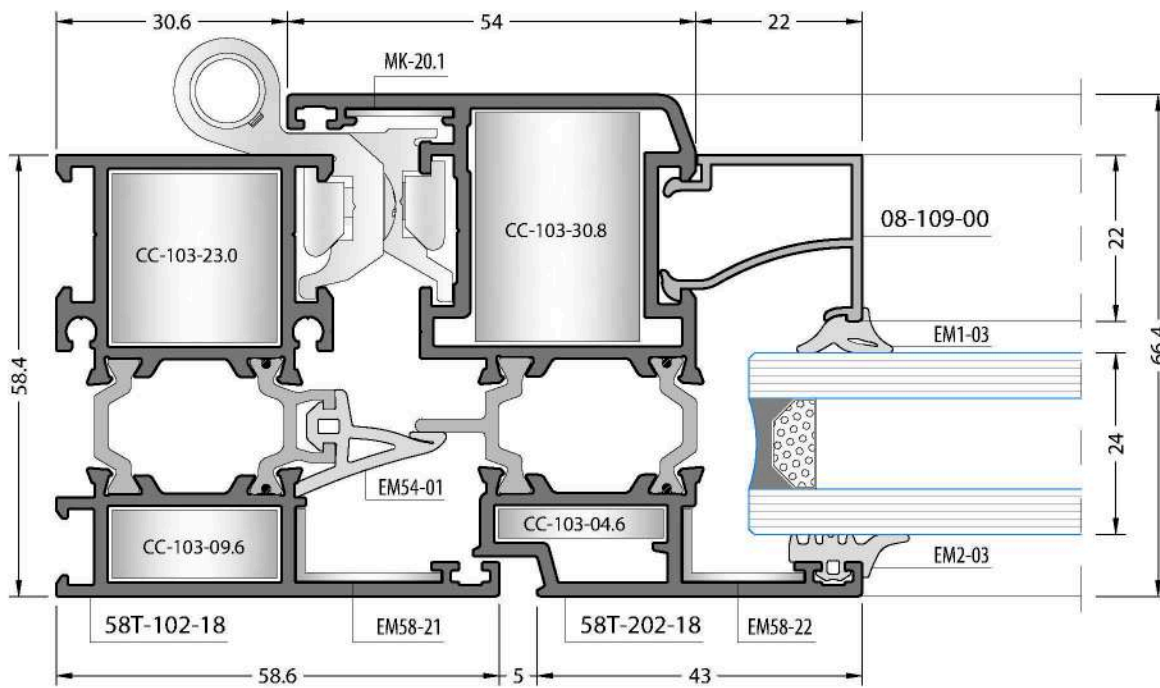
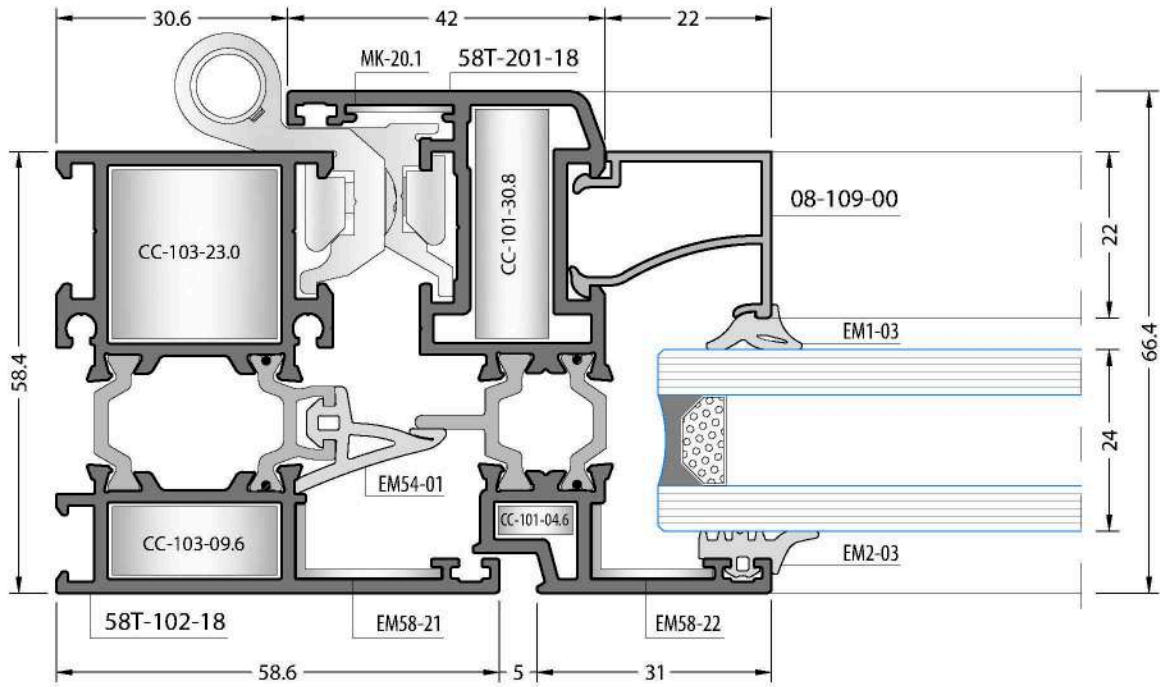
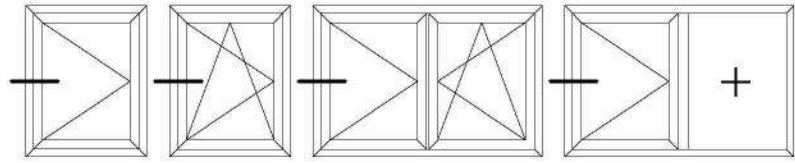

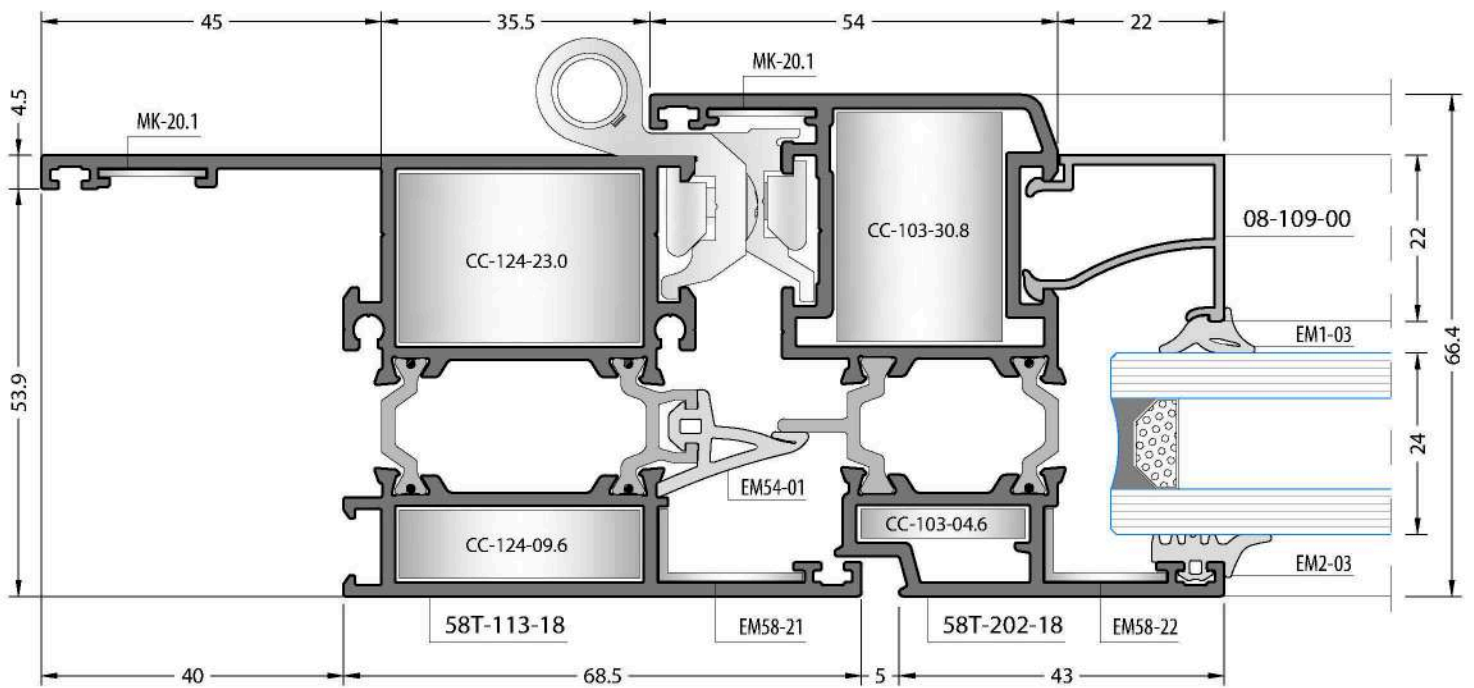
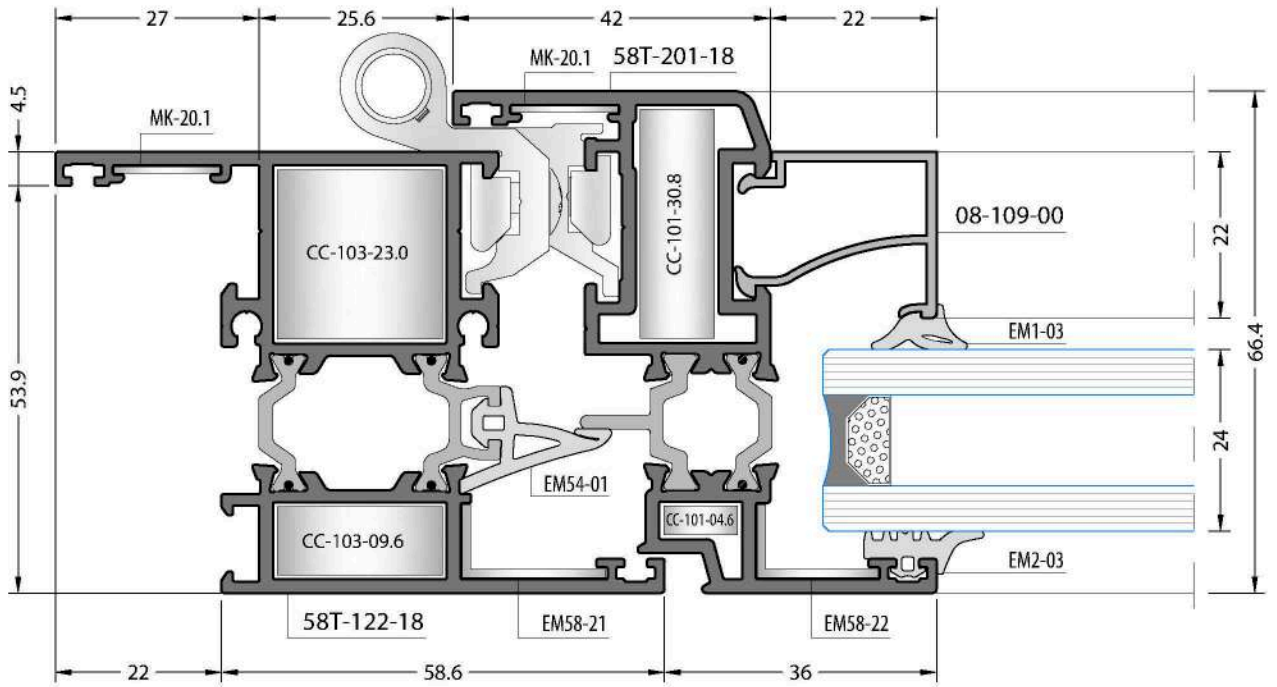
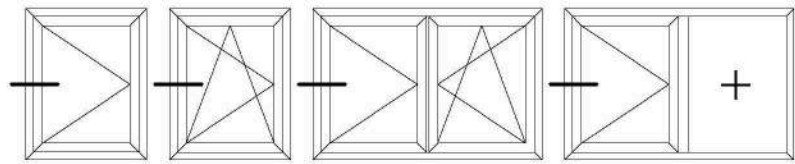

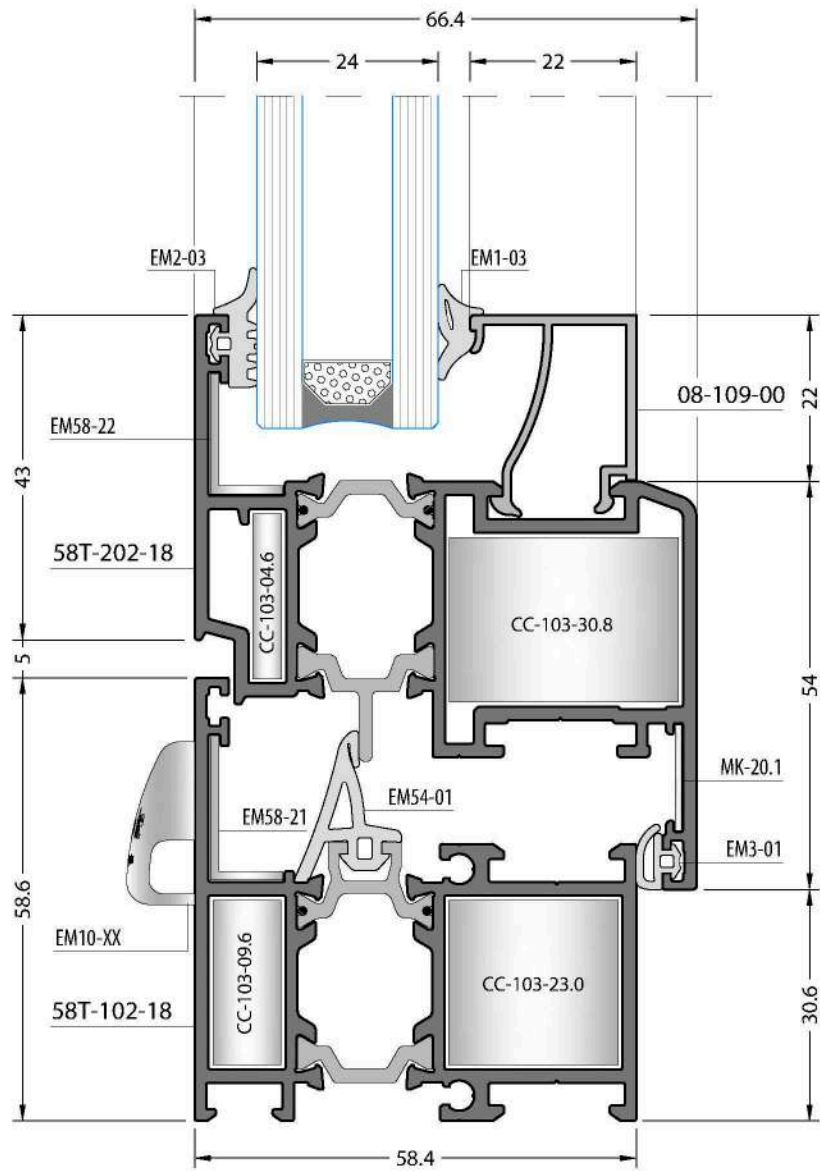
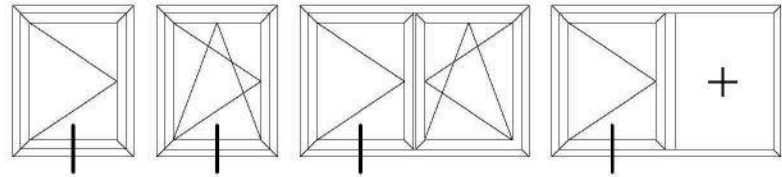

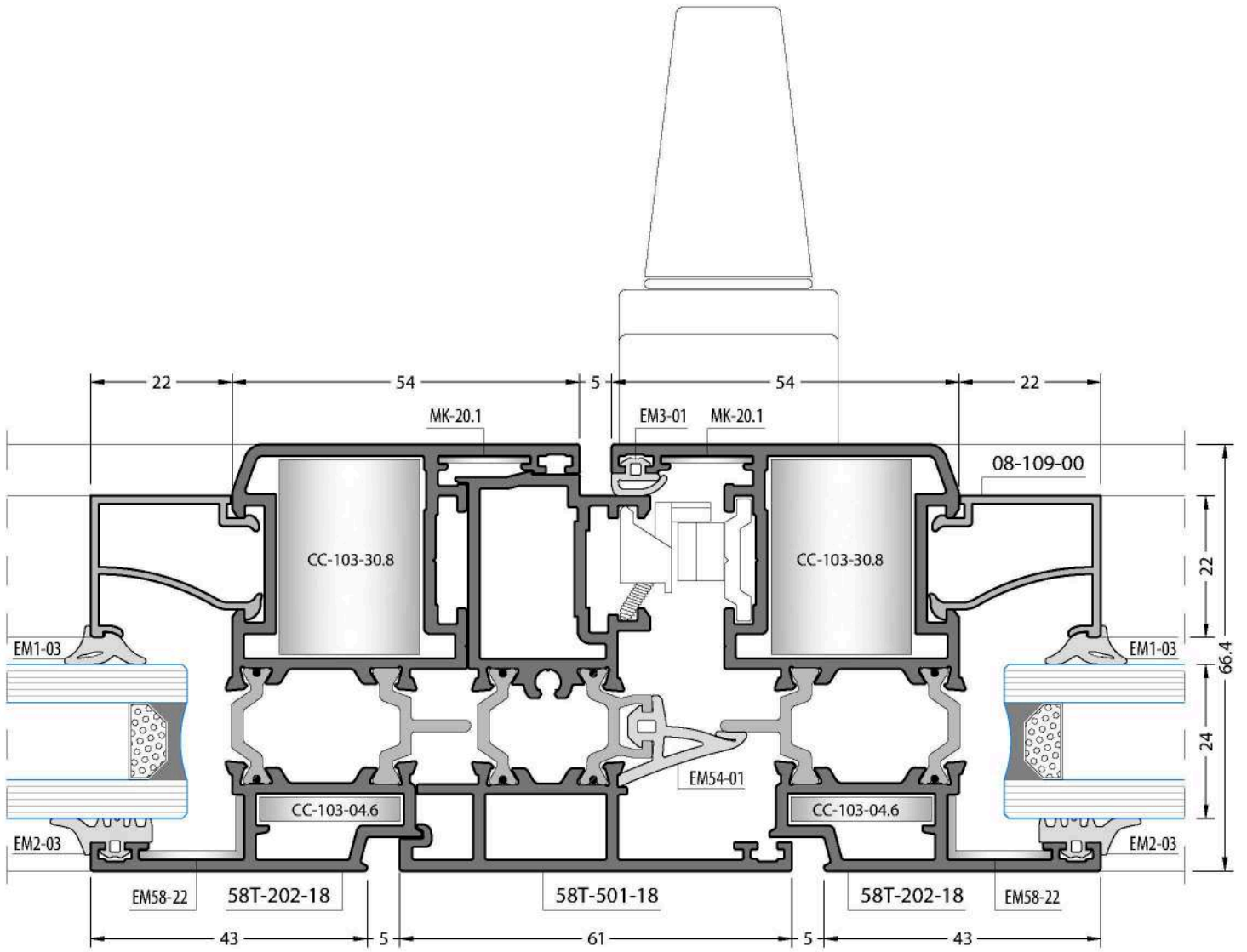
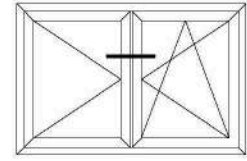

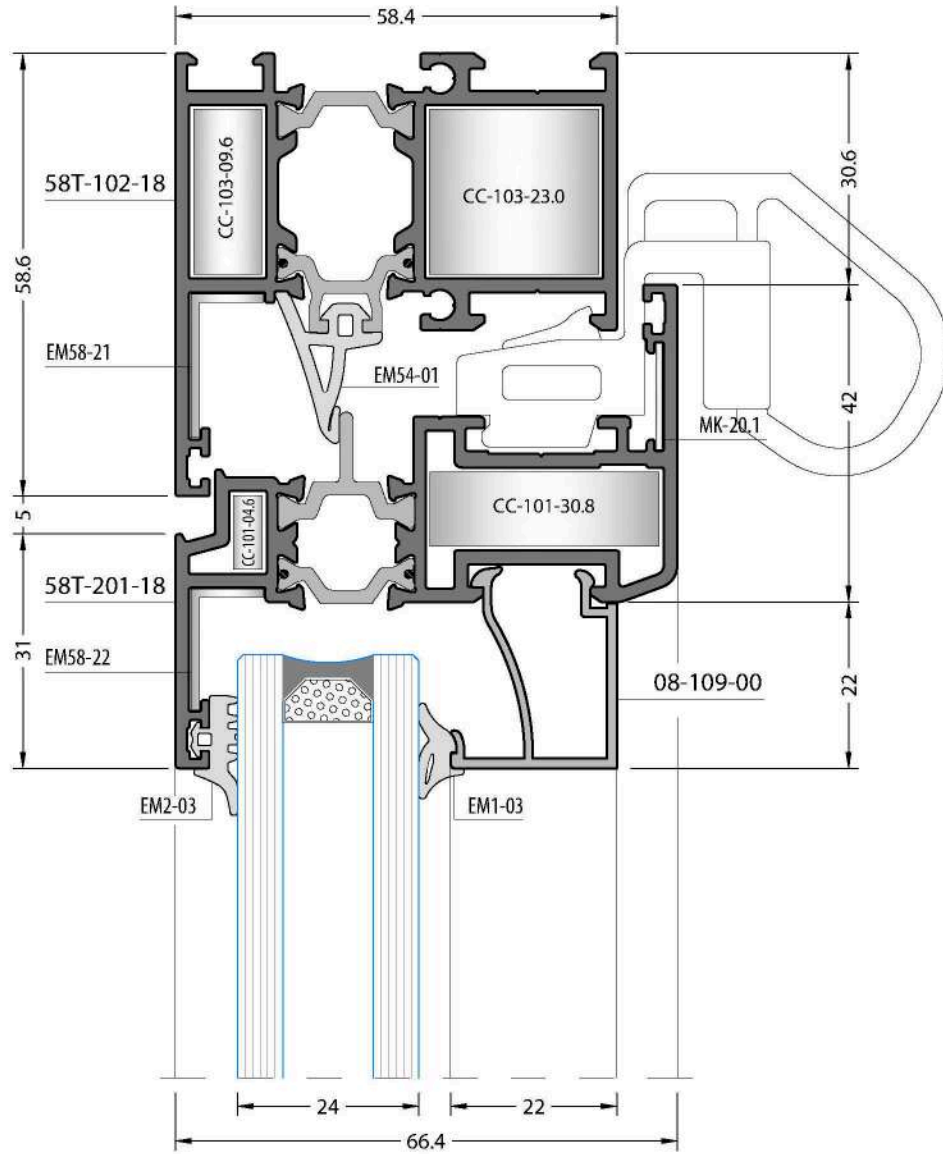
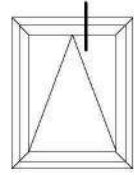

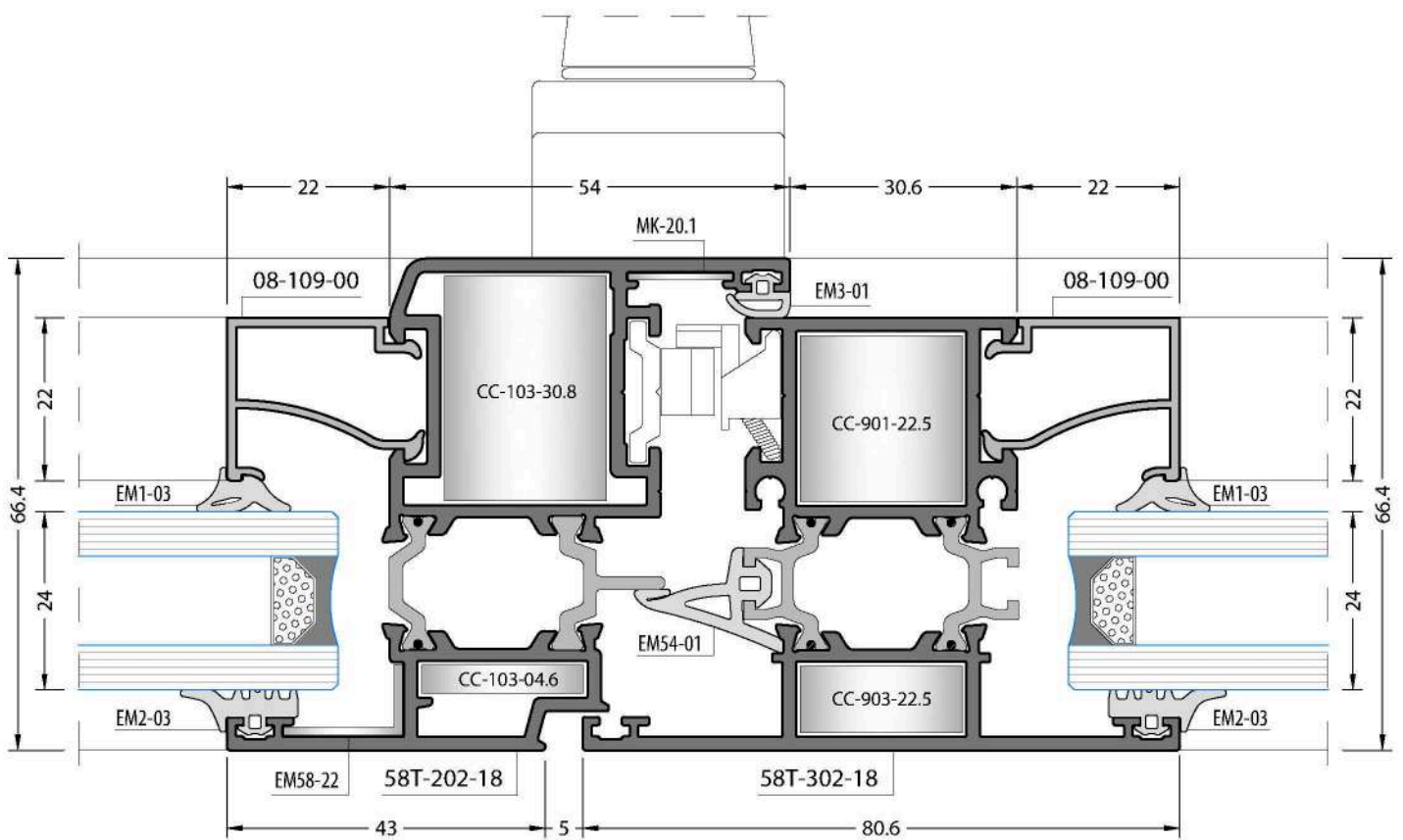
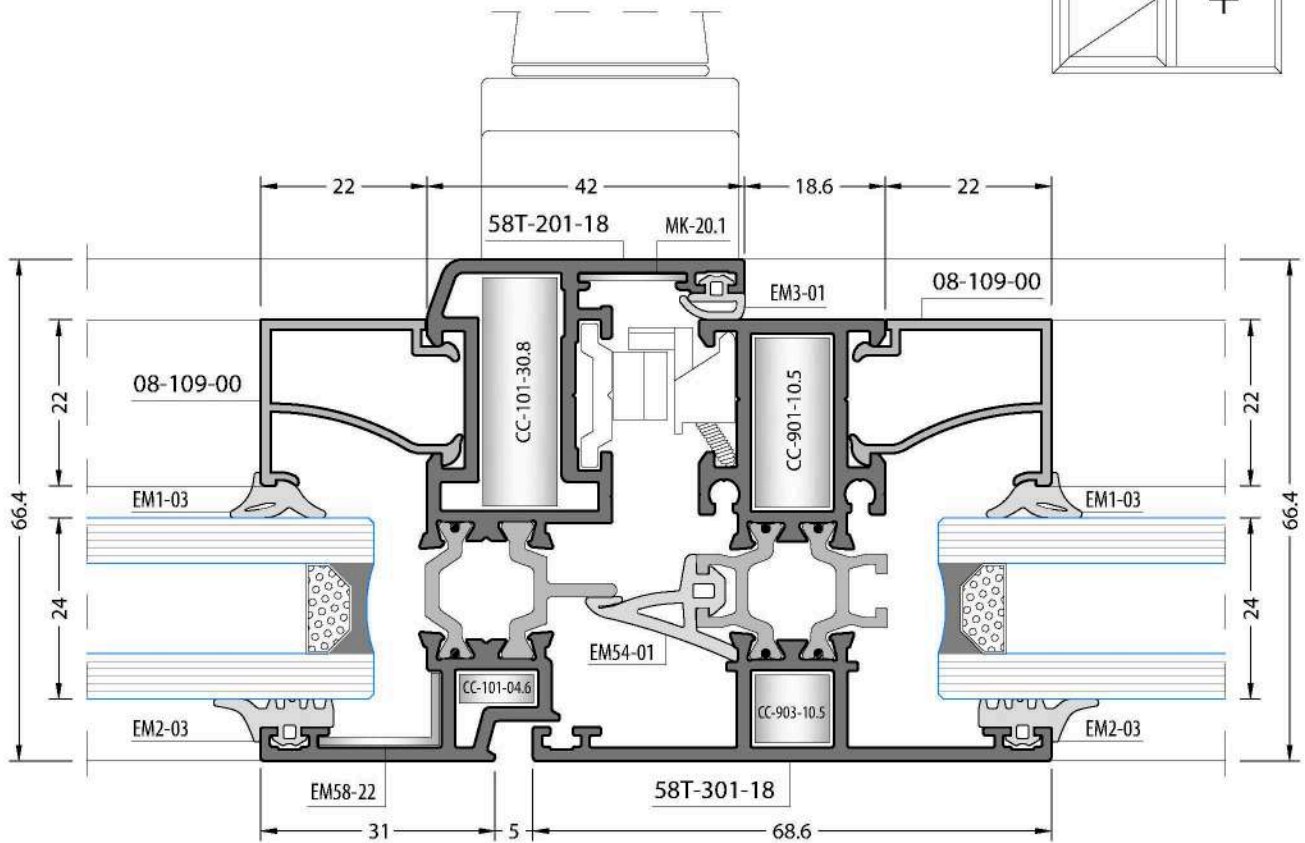
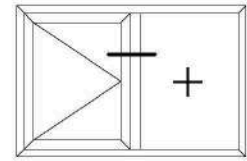

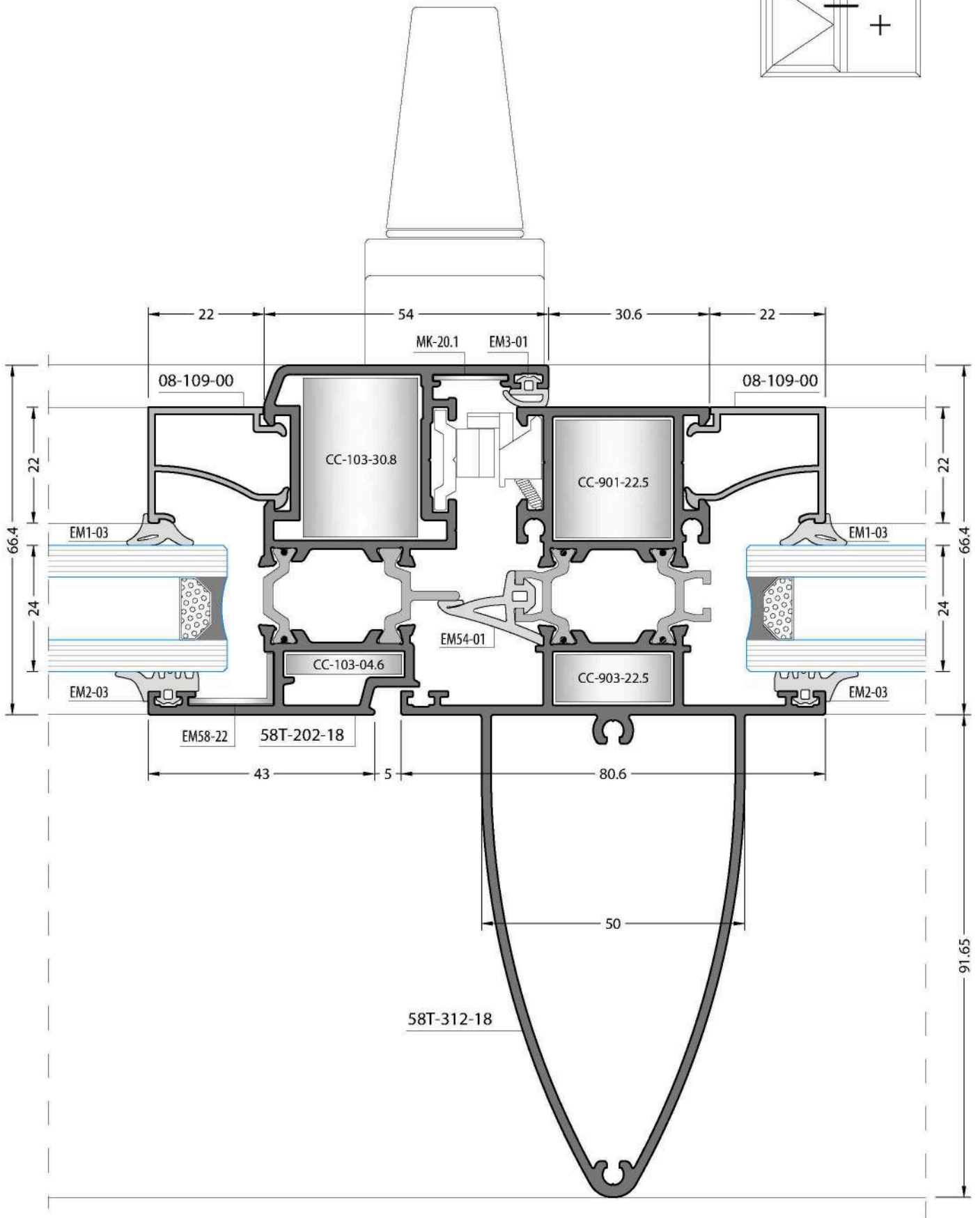
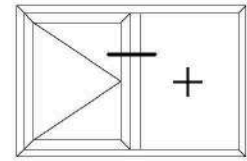

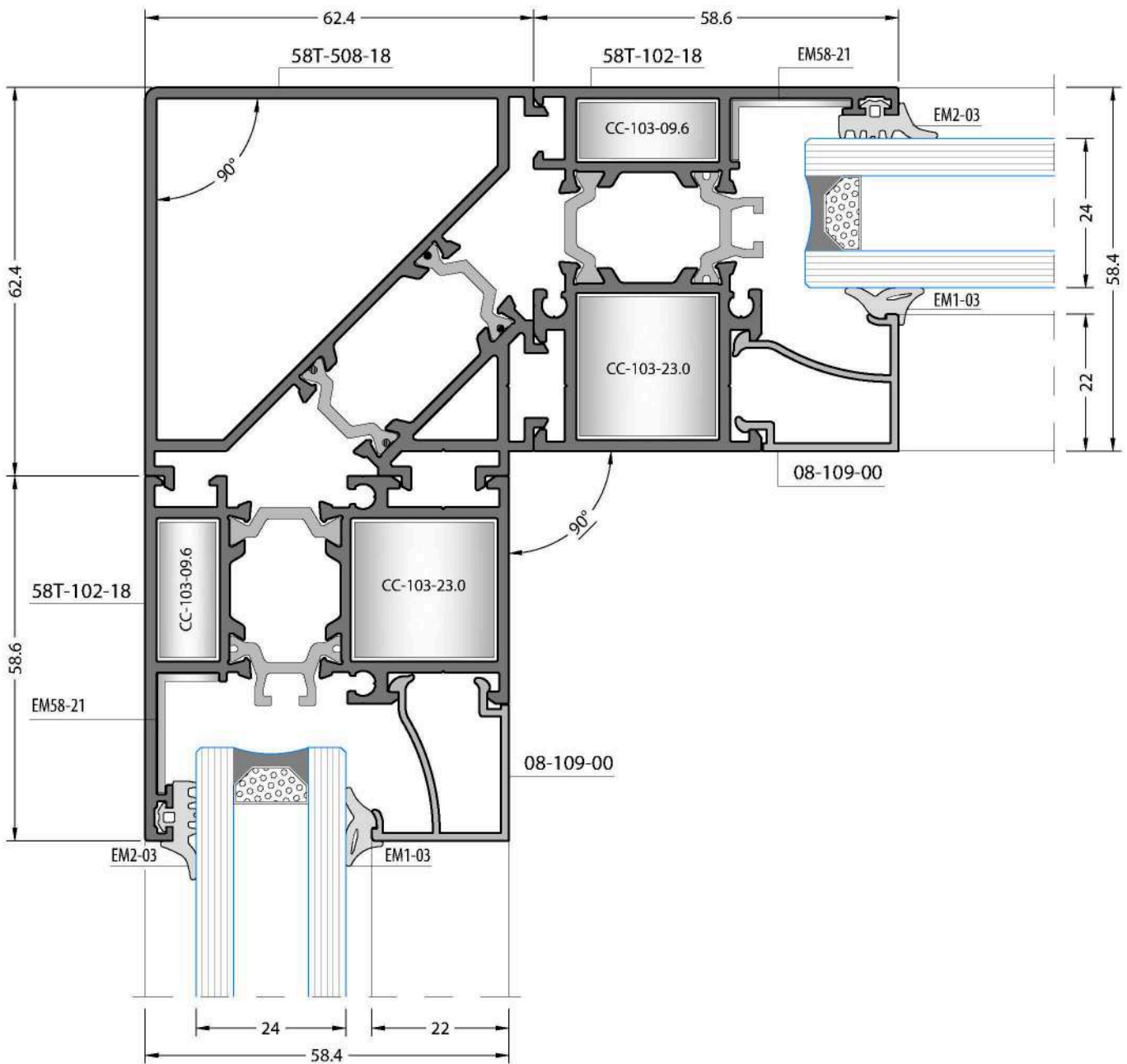
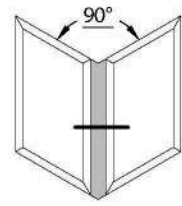

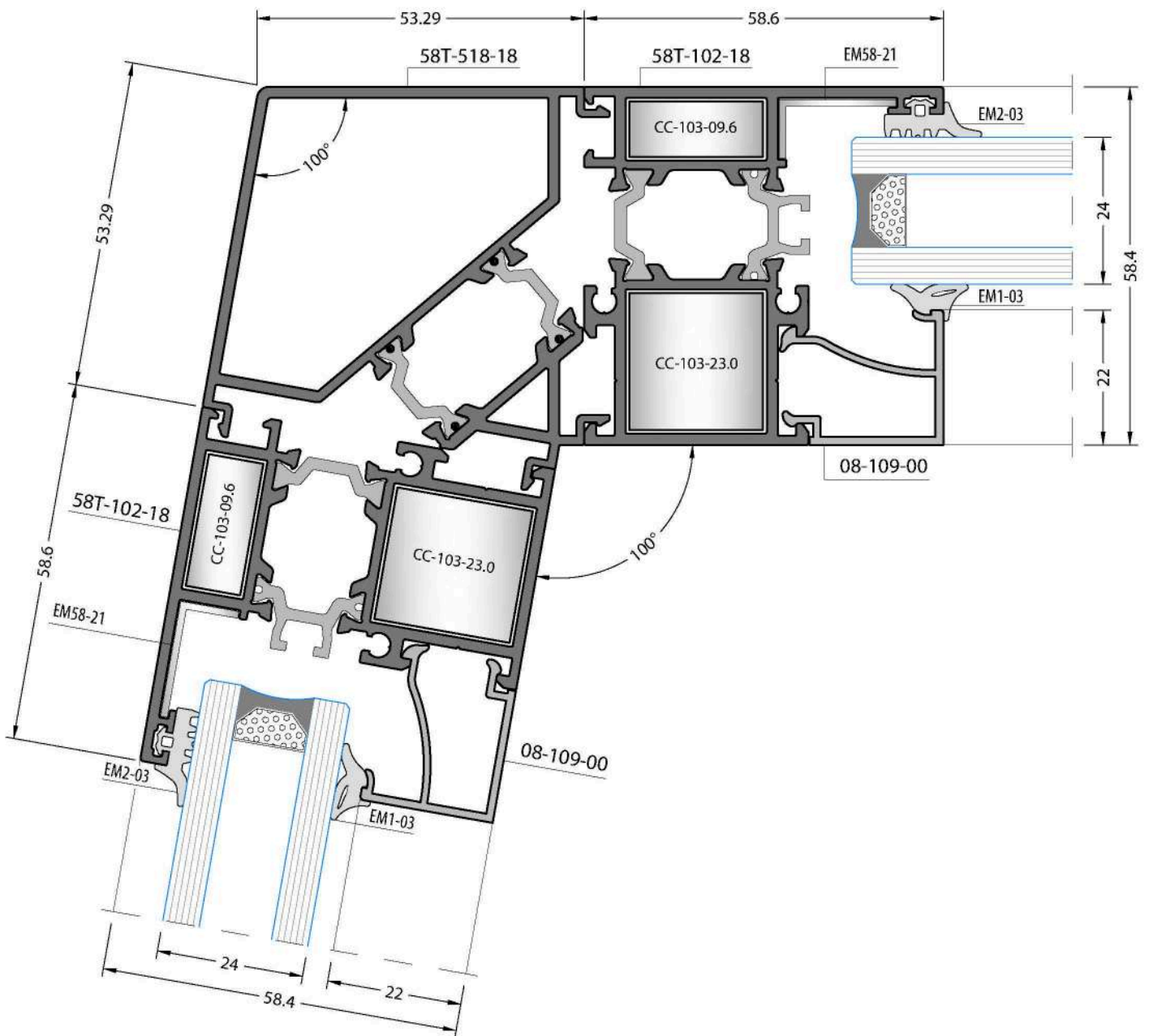
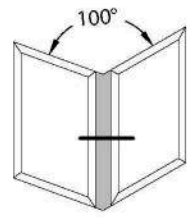

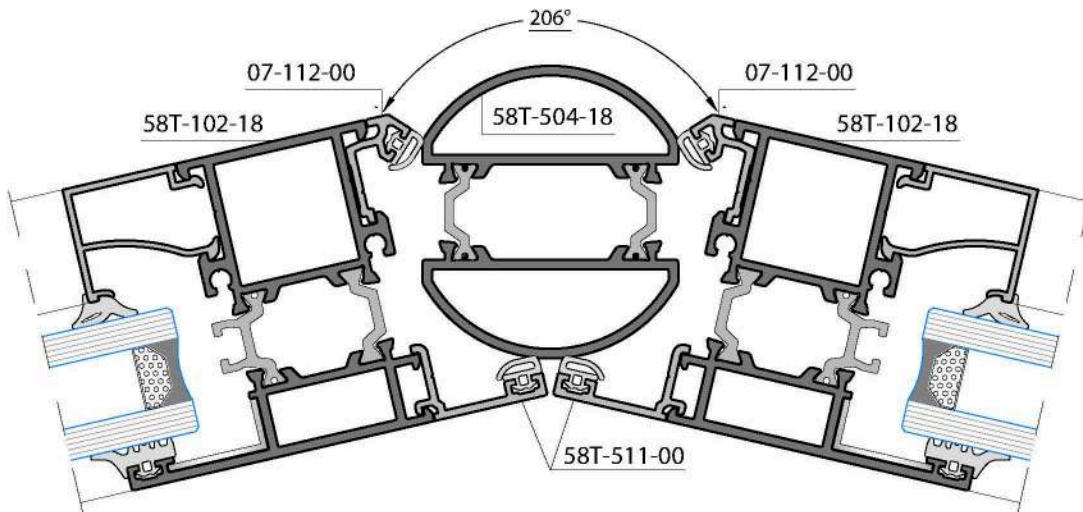
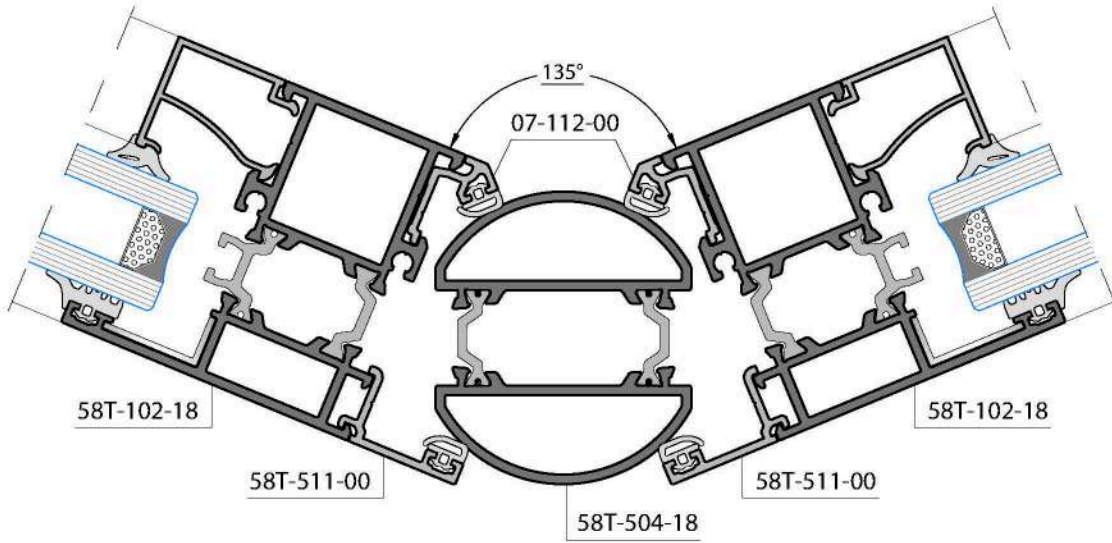
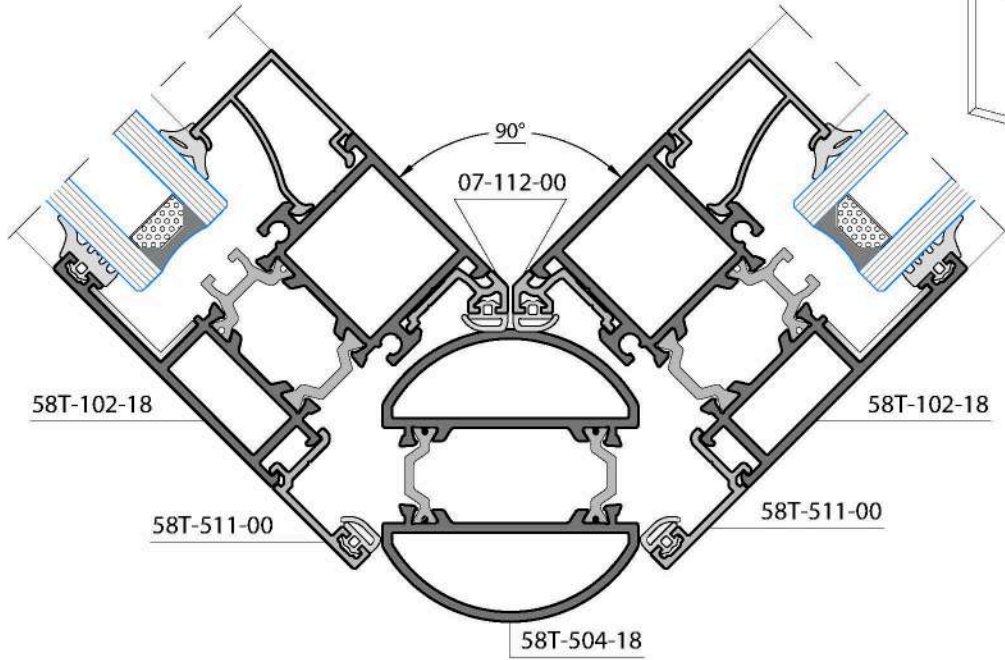
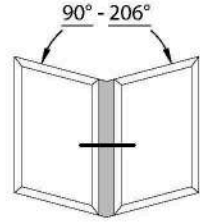

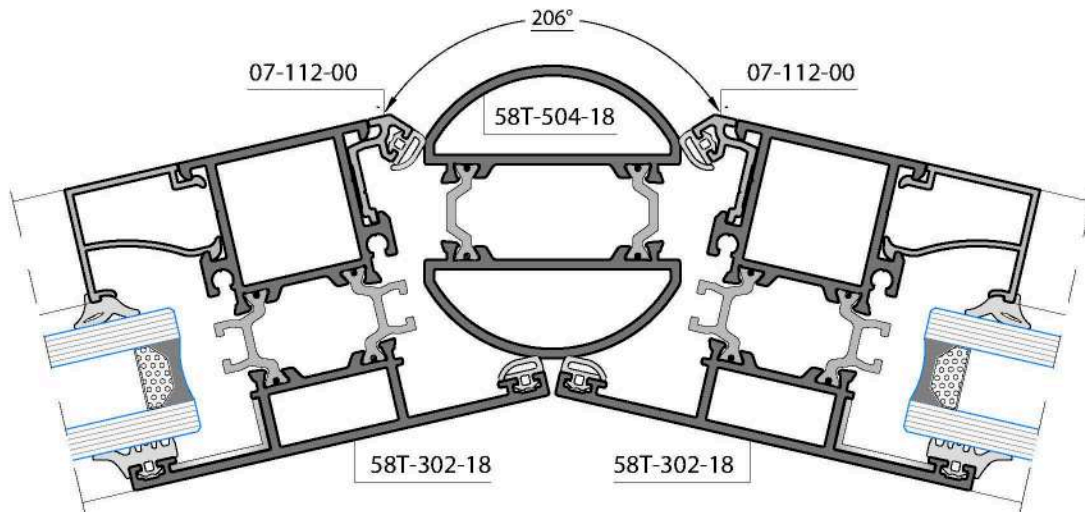
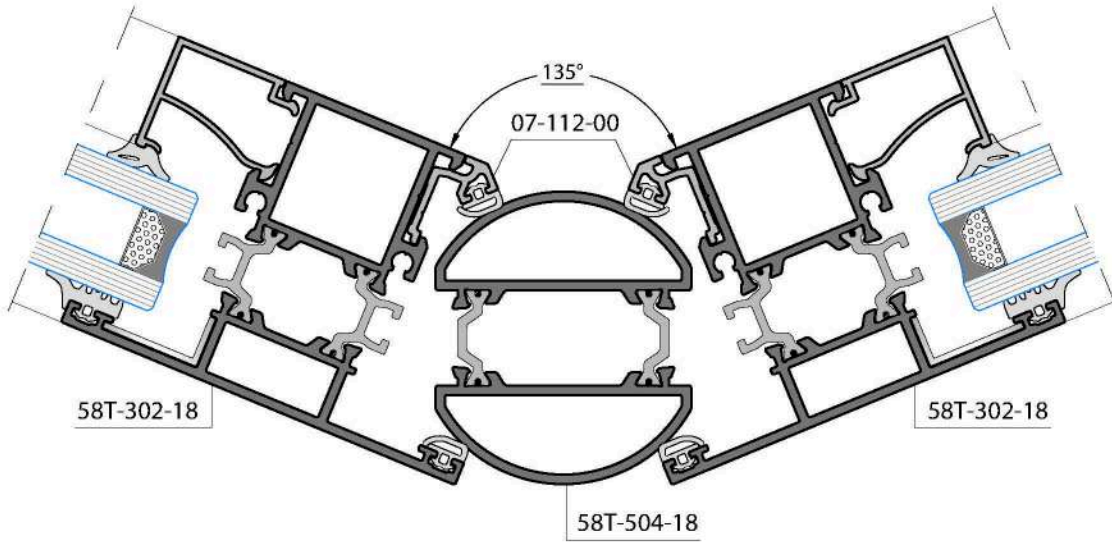
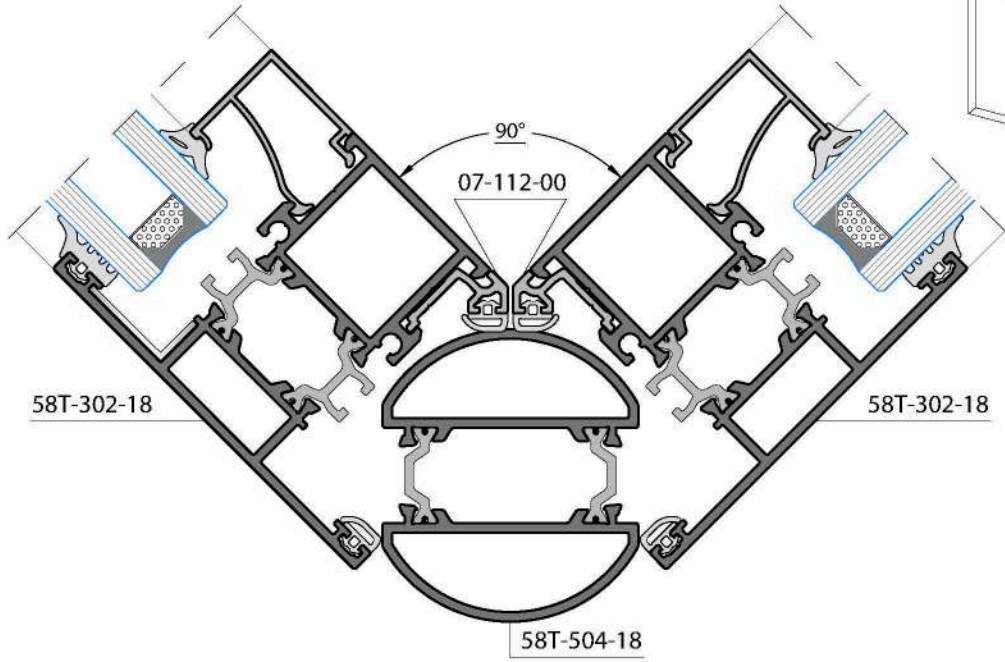
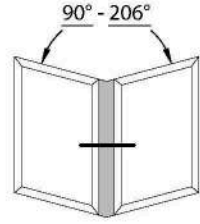

Exterior Window Sash Profile Details / Dışa Açılır Pencere Kanat Profil Detayları

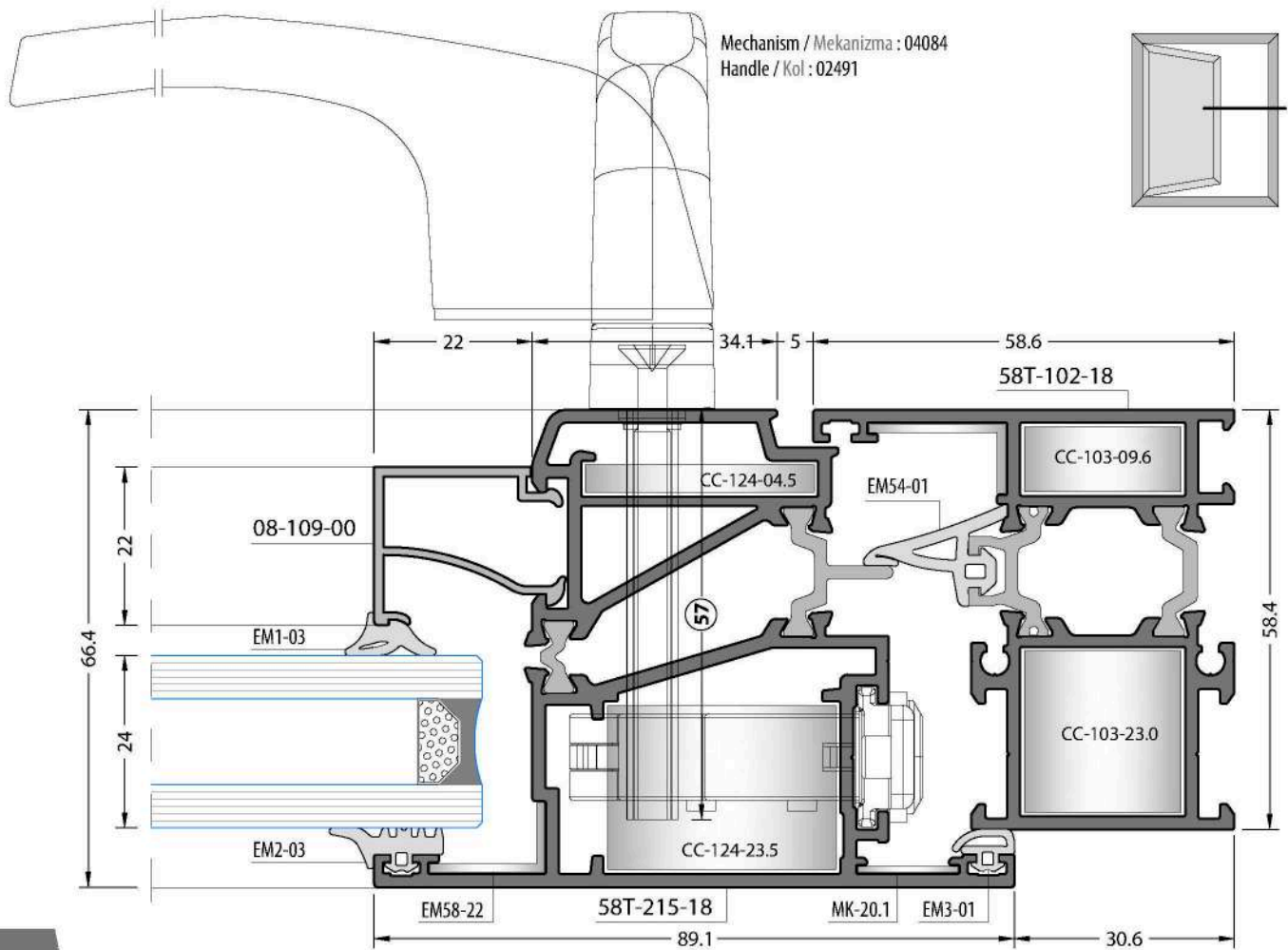
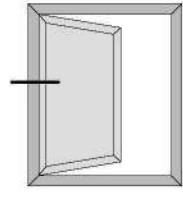
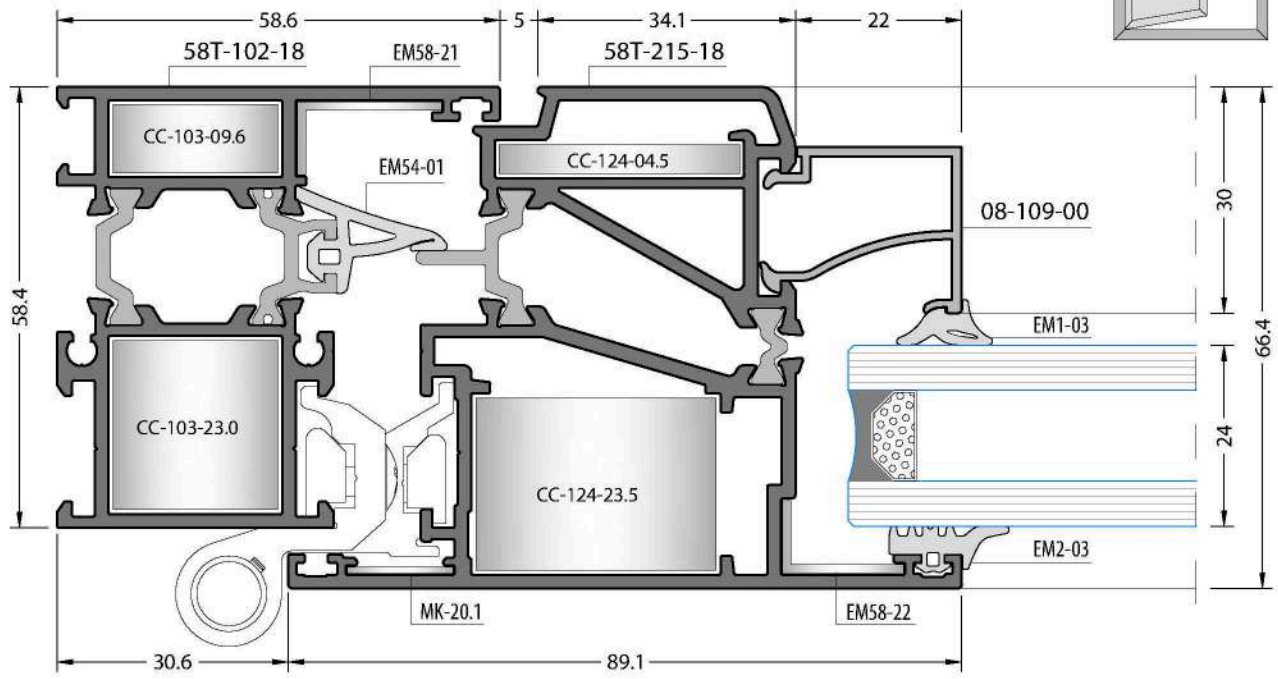

Mechanism / Mekanizma : 04084
Handle / Kol : 02491

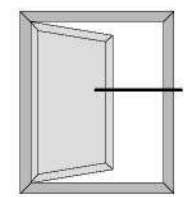

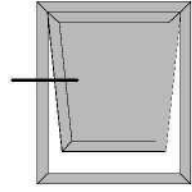

Exterior Window Sash Profile Details / Dışa Açılır Pencere Kanat Profil Detayları

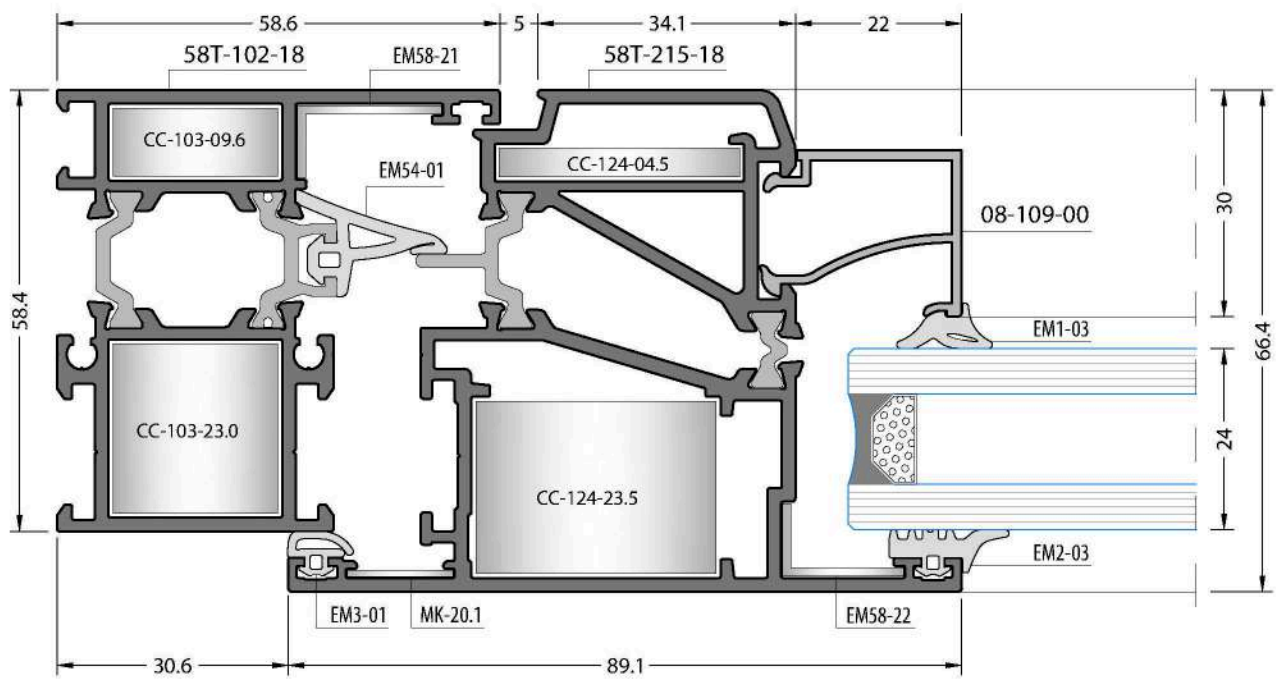

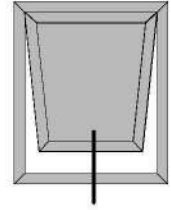

Exterior Window Sash Profile Details / Dışa Açılır Pencere Kanat Profil Detayları

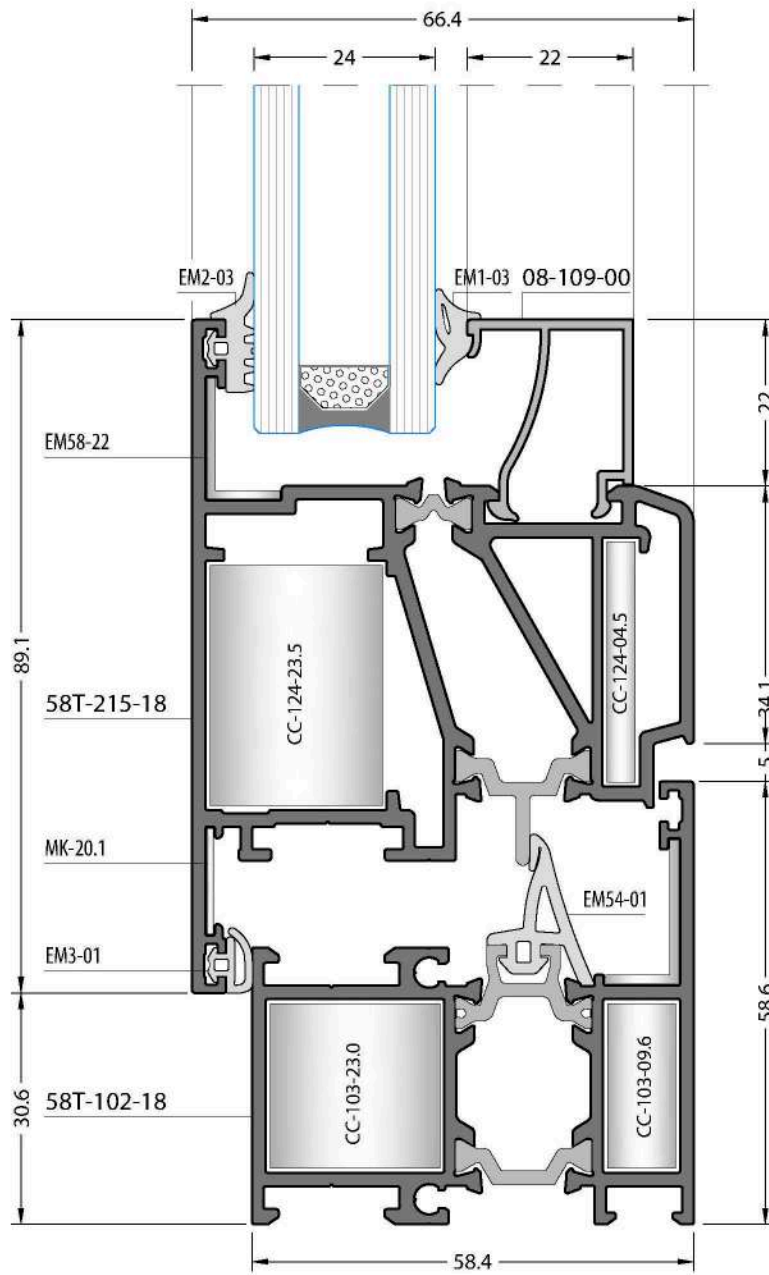

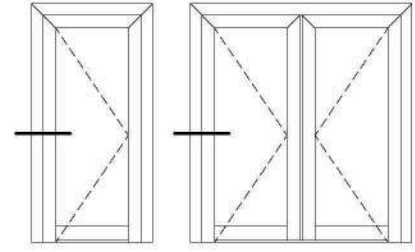

Inside Opening Door
İçe Açılır Kapı

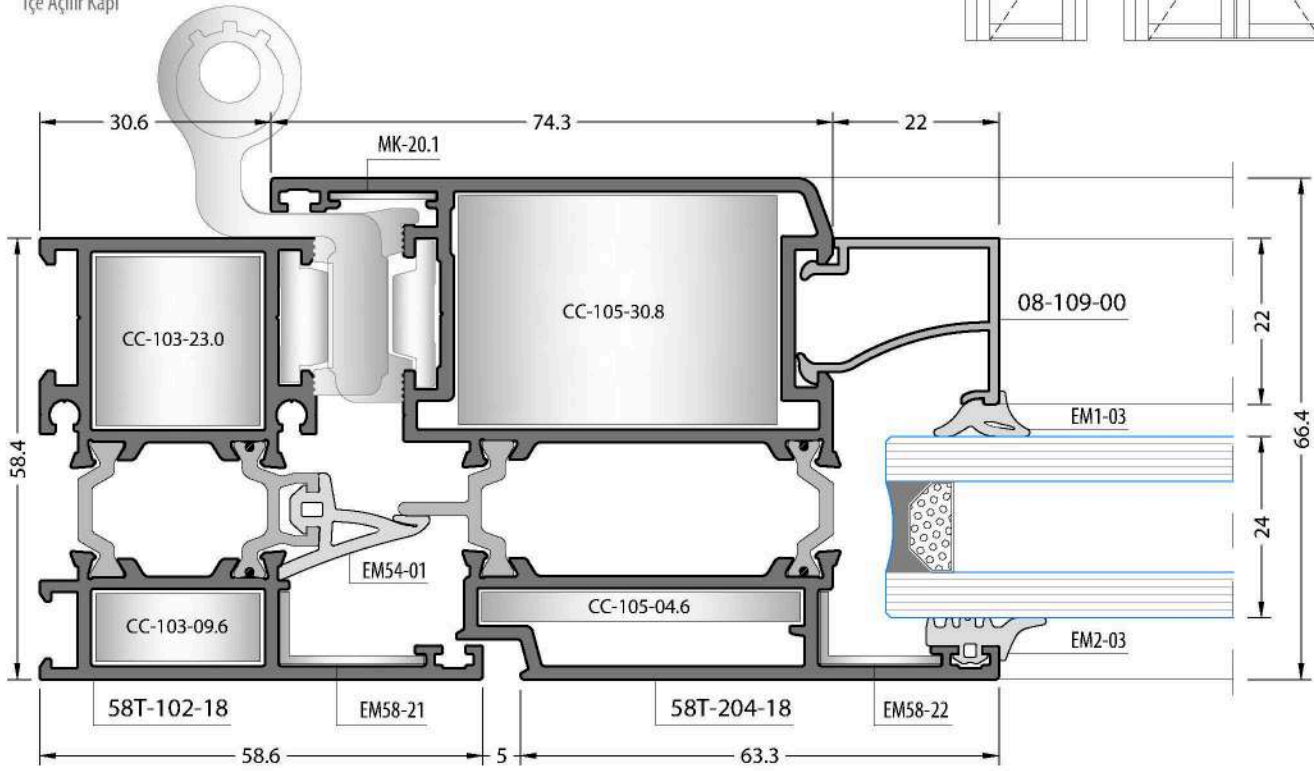

Inside Opening Door
İçe Açılır Kapı

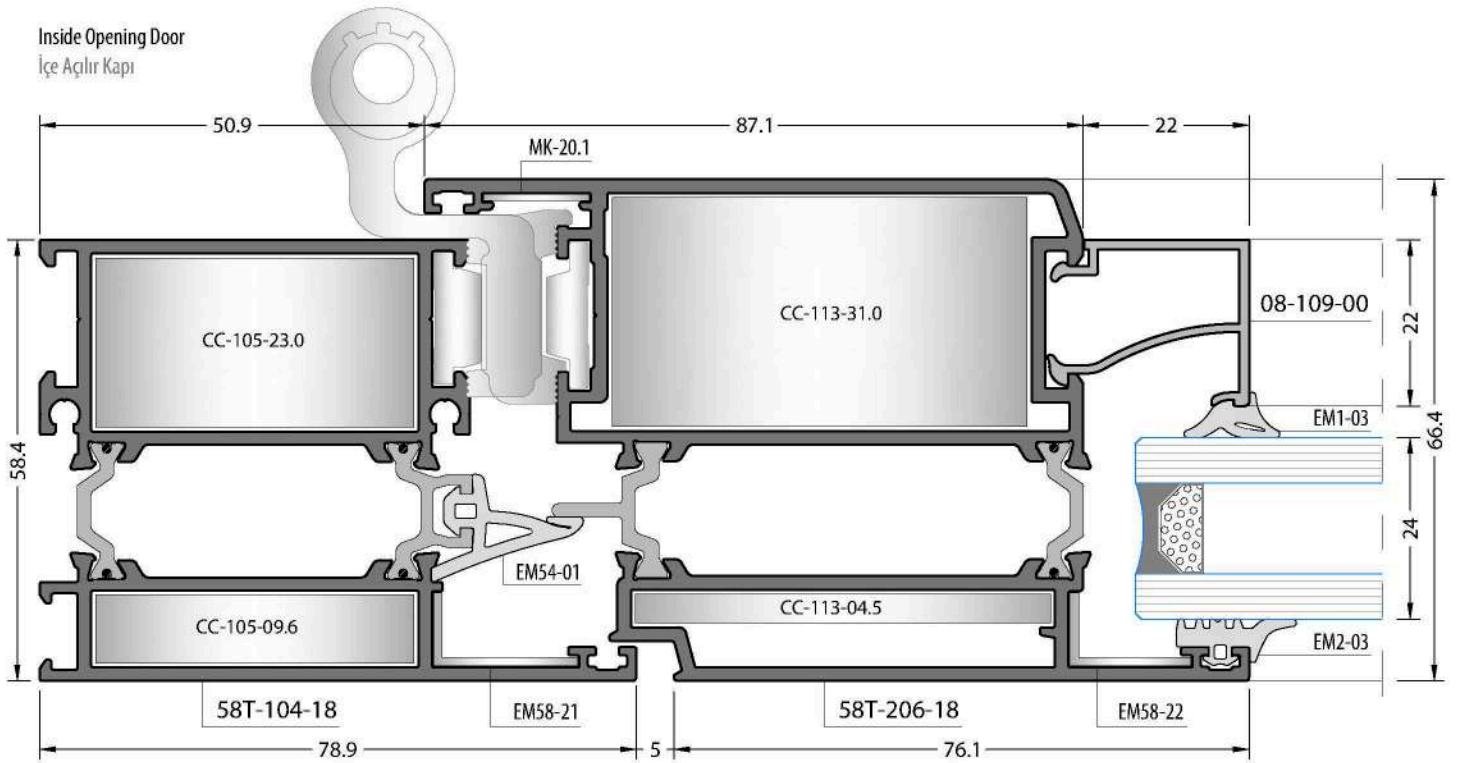

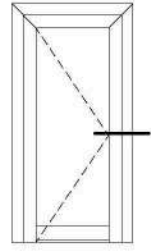

Inside Opening Door
İçe Açılır Kapi

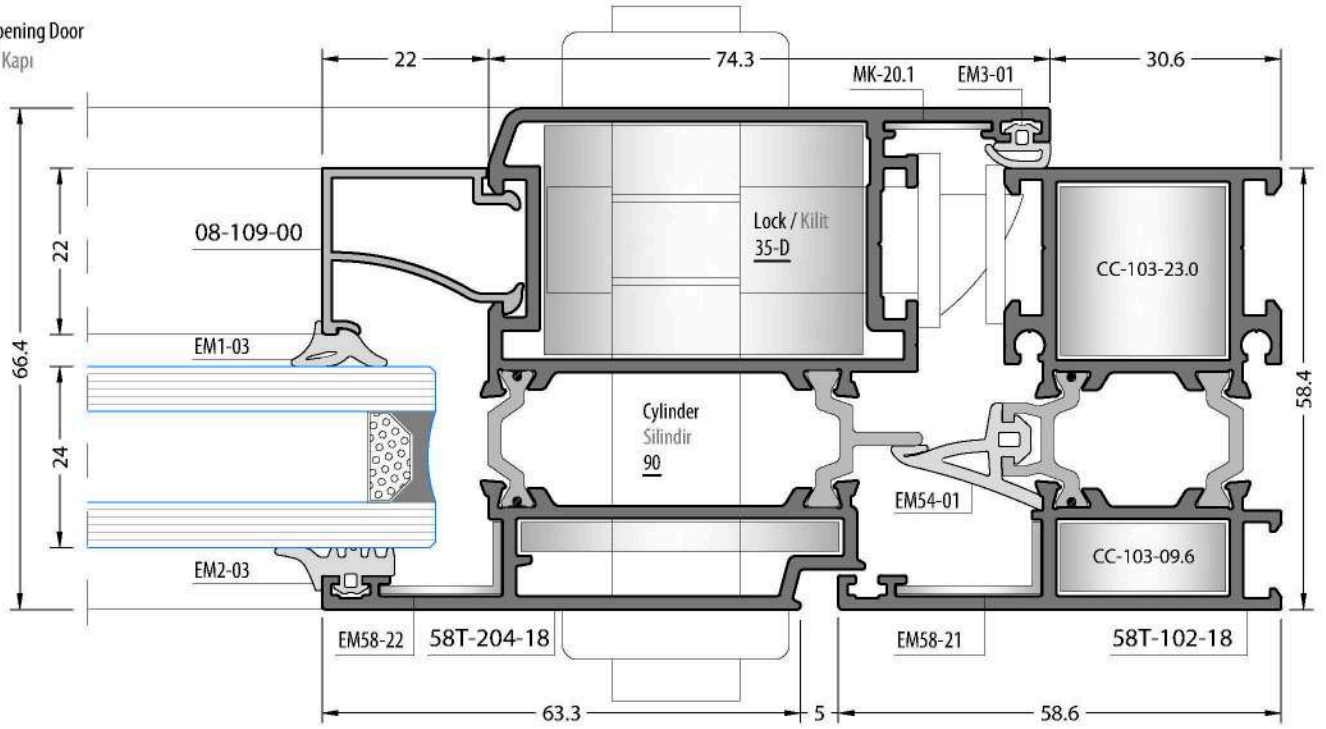

Inside Opening Door
İçe Açılır Kapi

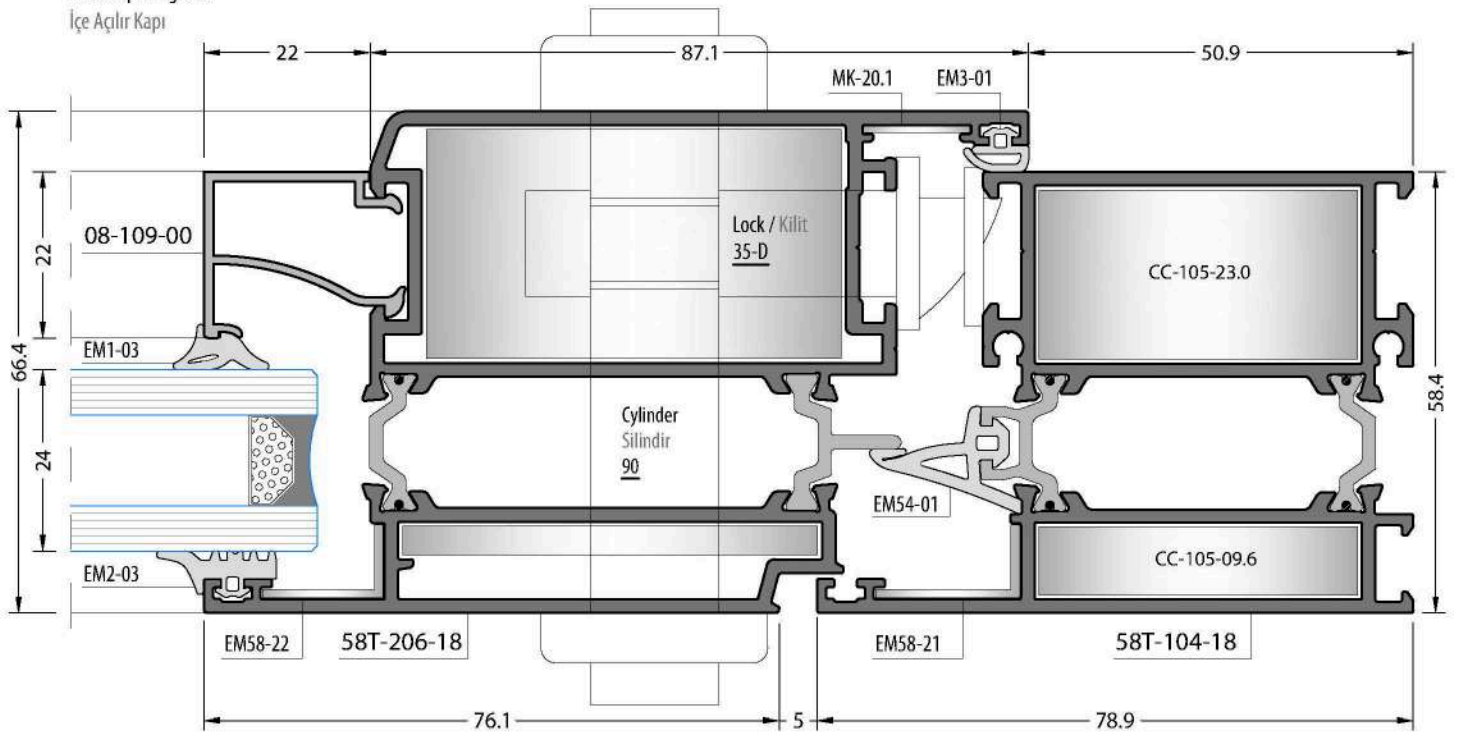

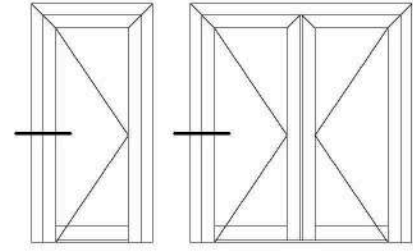

Outside Opening Door
Dışa Açılır Kapi

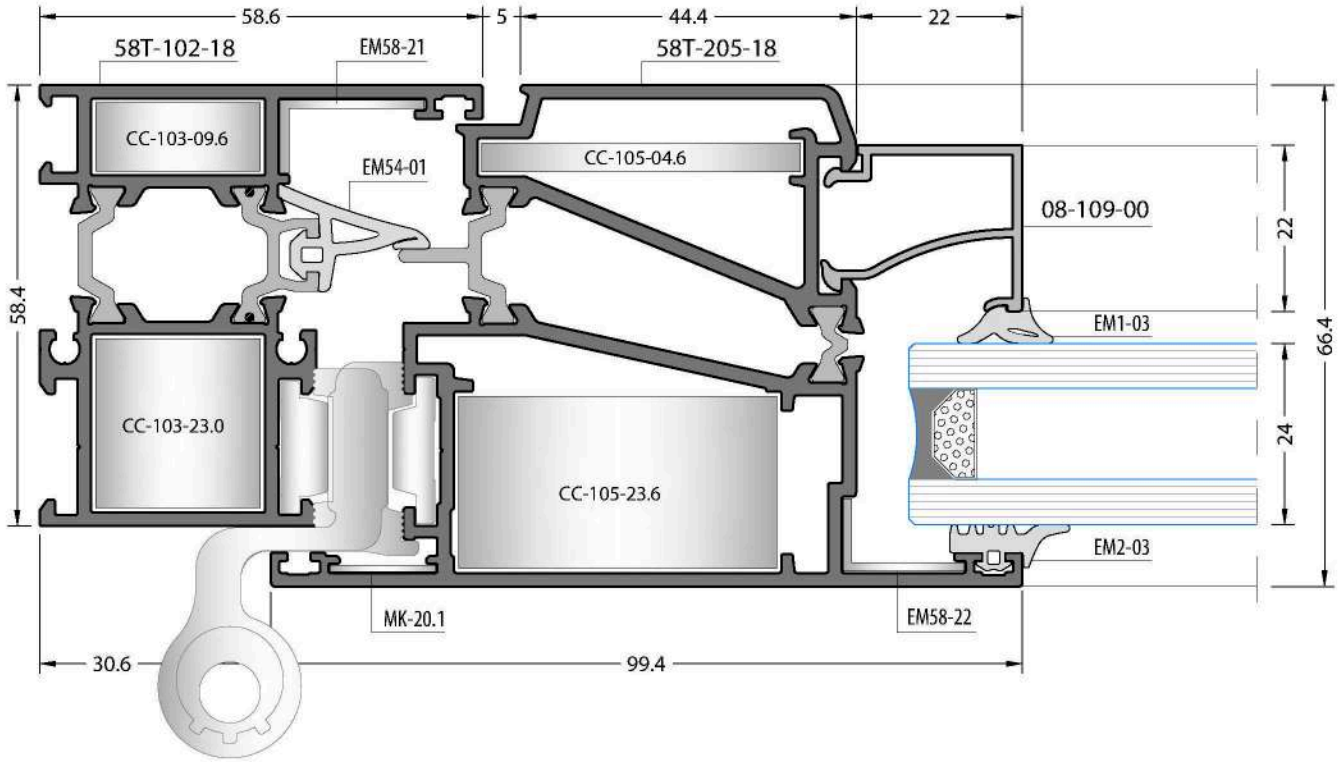

Outside Opening Door
Dışa Açılır Kapi

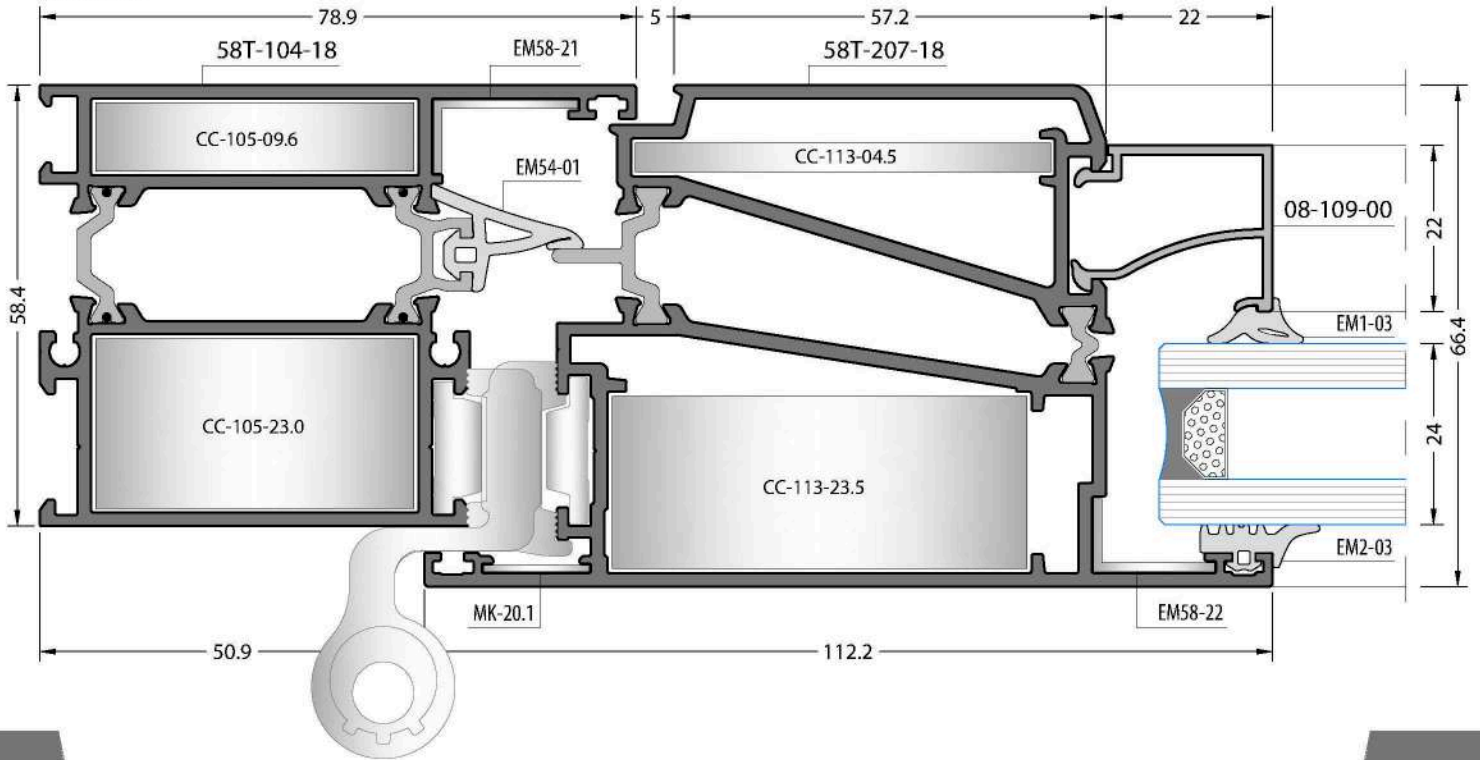

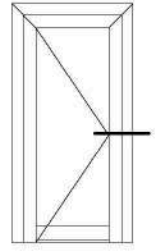

Outside Opening Door
Dışa Açılır Kapi

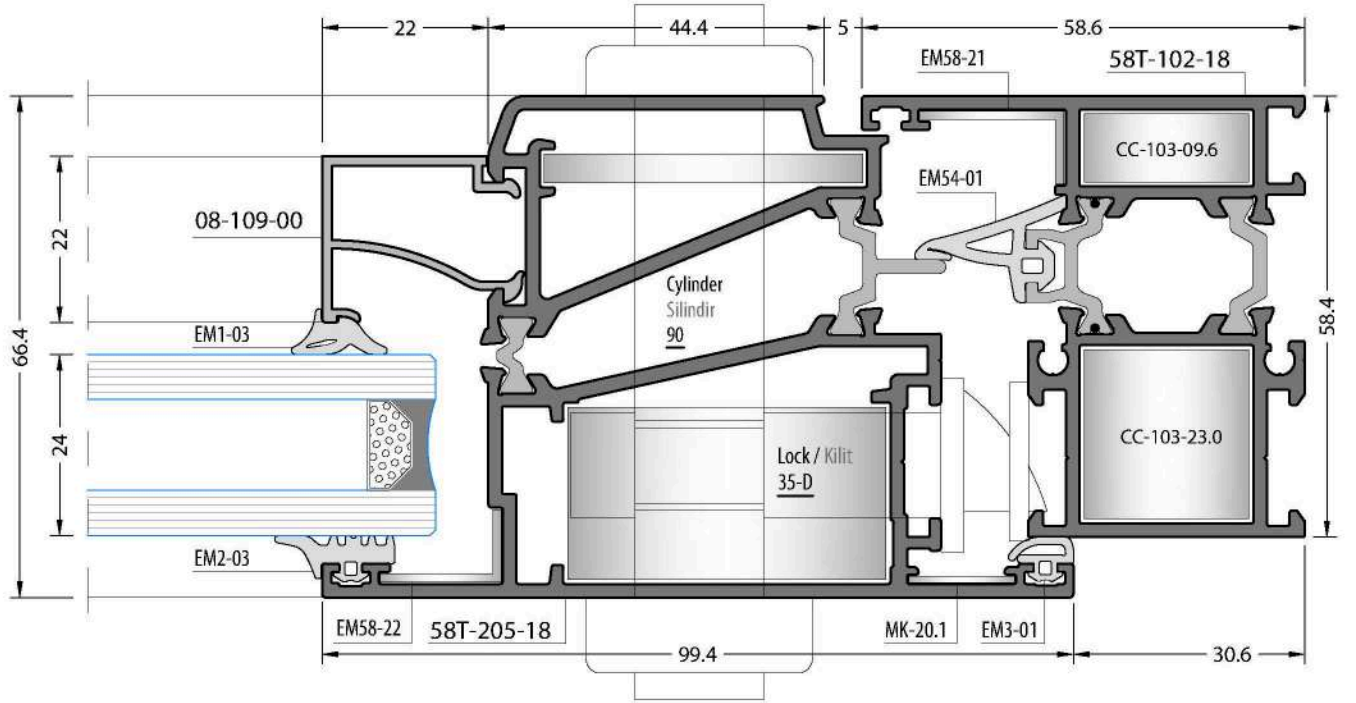

Outside Opening Door
Dışa Açılır Kapi

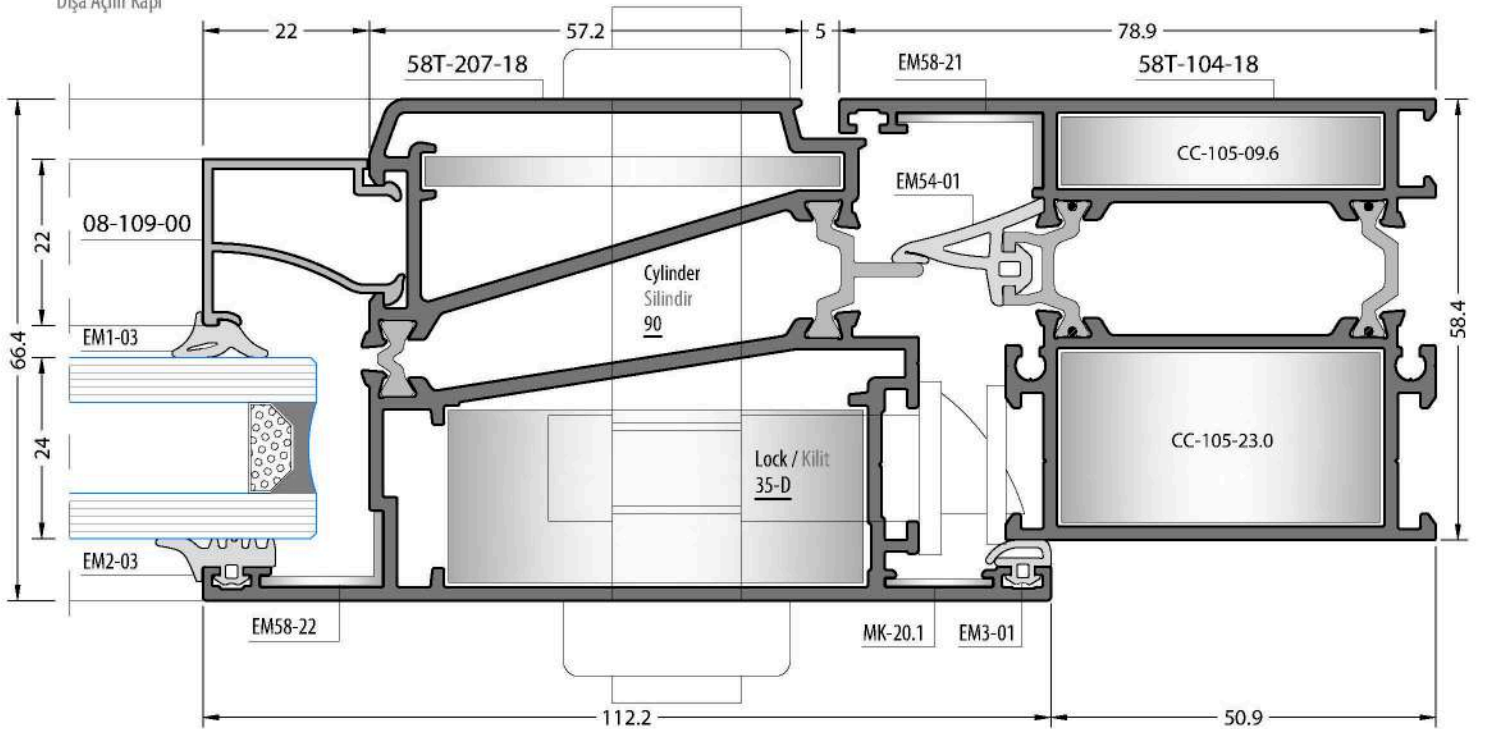

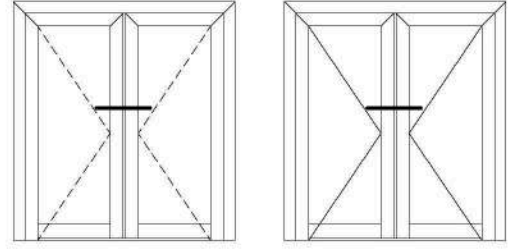

Inside Opening Door
İçe Açılır Kapı

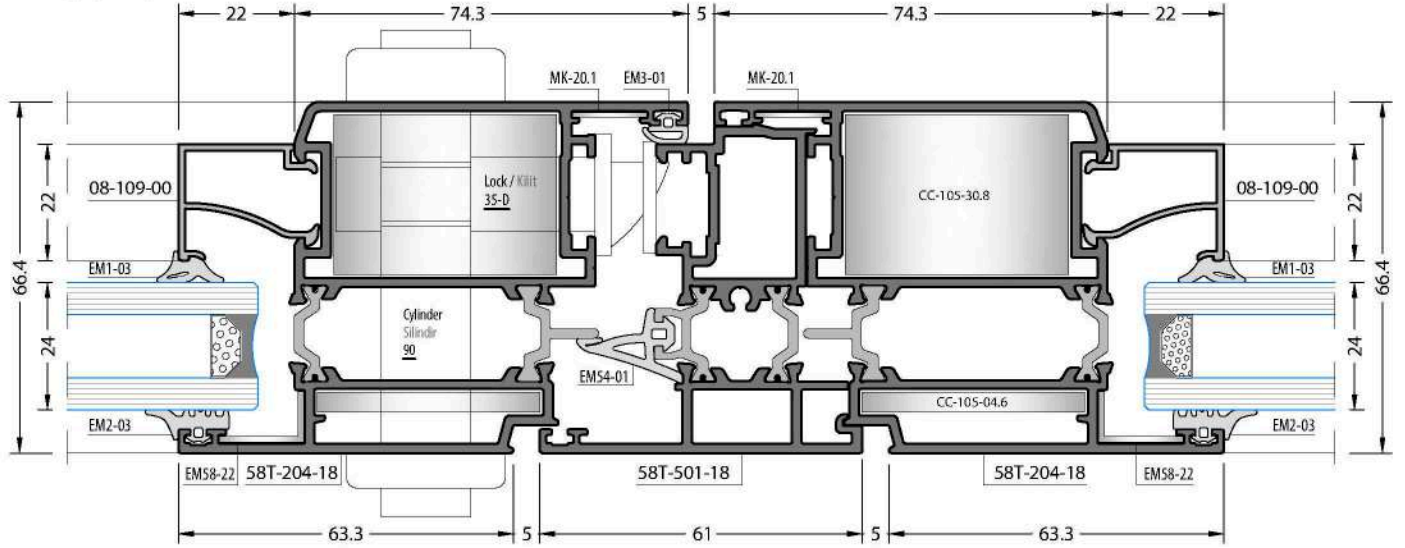

Outside Opening Door
Dışa Açılır Kapı

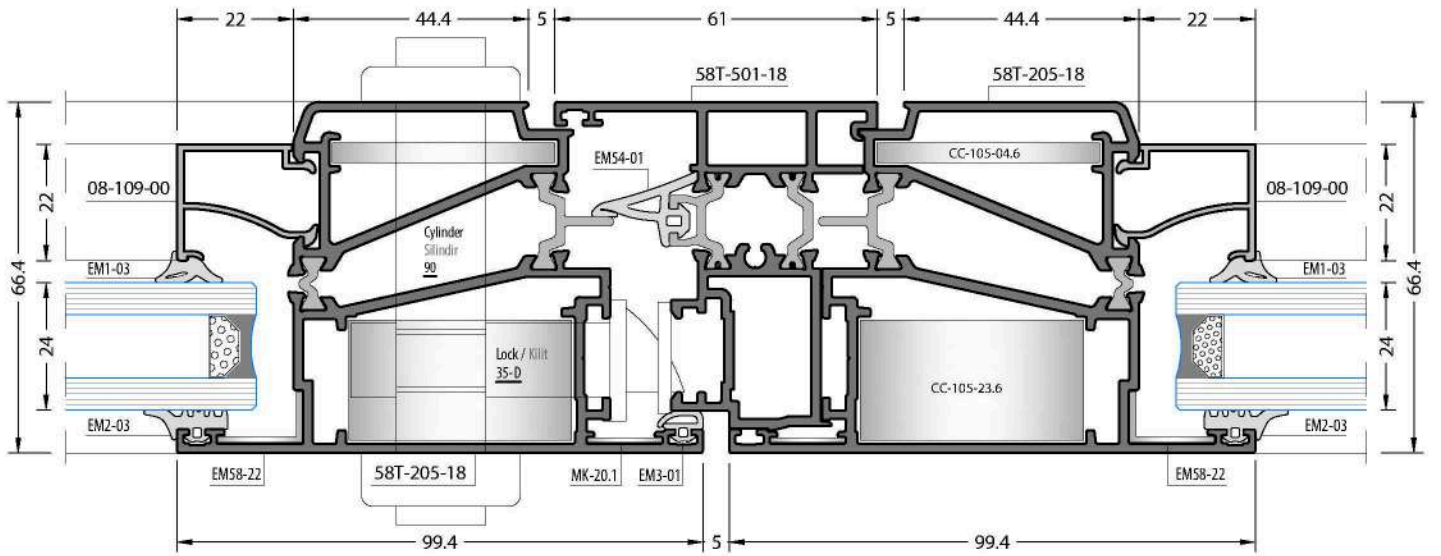

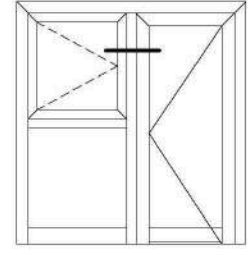

Inside Window and Outside Opening Door
İçe Açılır Pencere ve Dışa Açılır Kapi

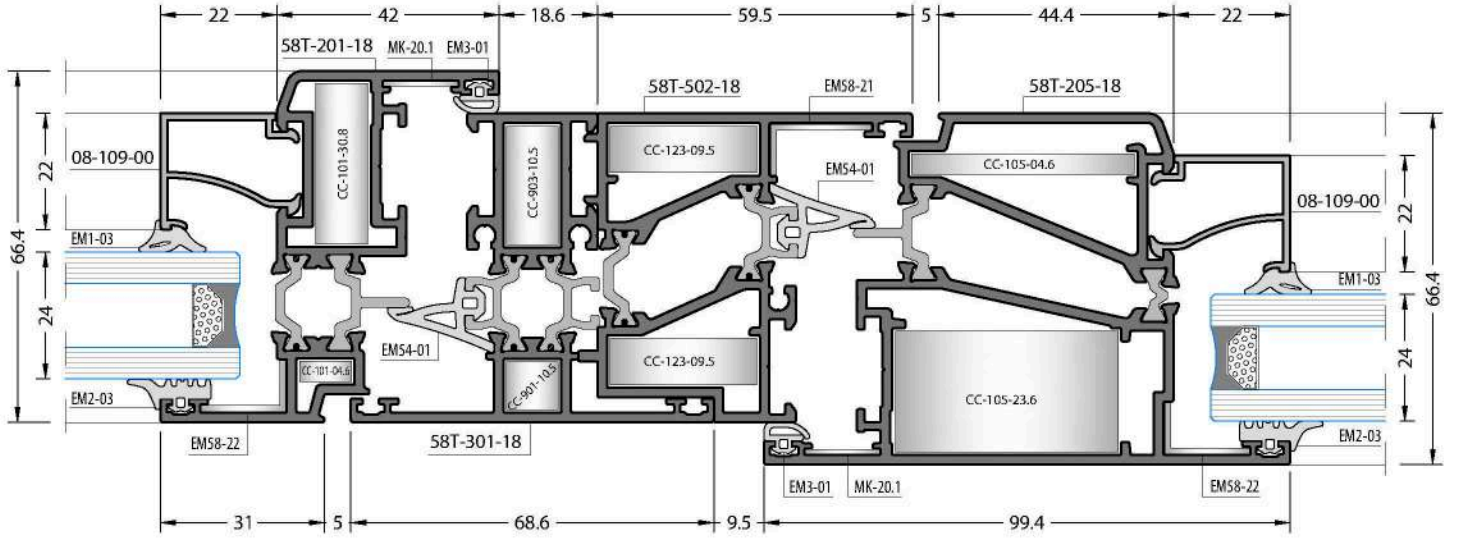

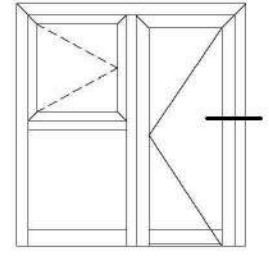

Inside Window and Outside Opening Door
İçe Açılır Pencere ve Dışa Açılır Kapi

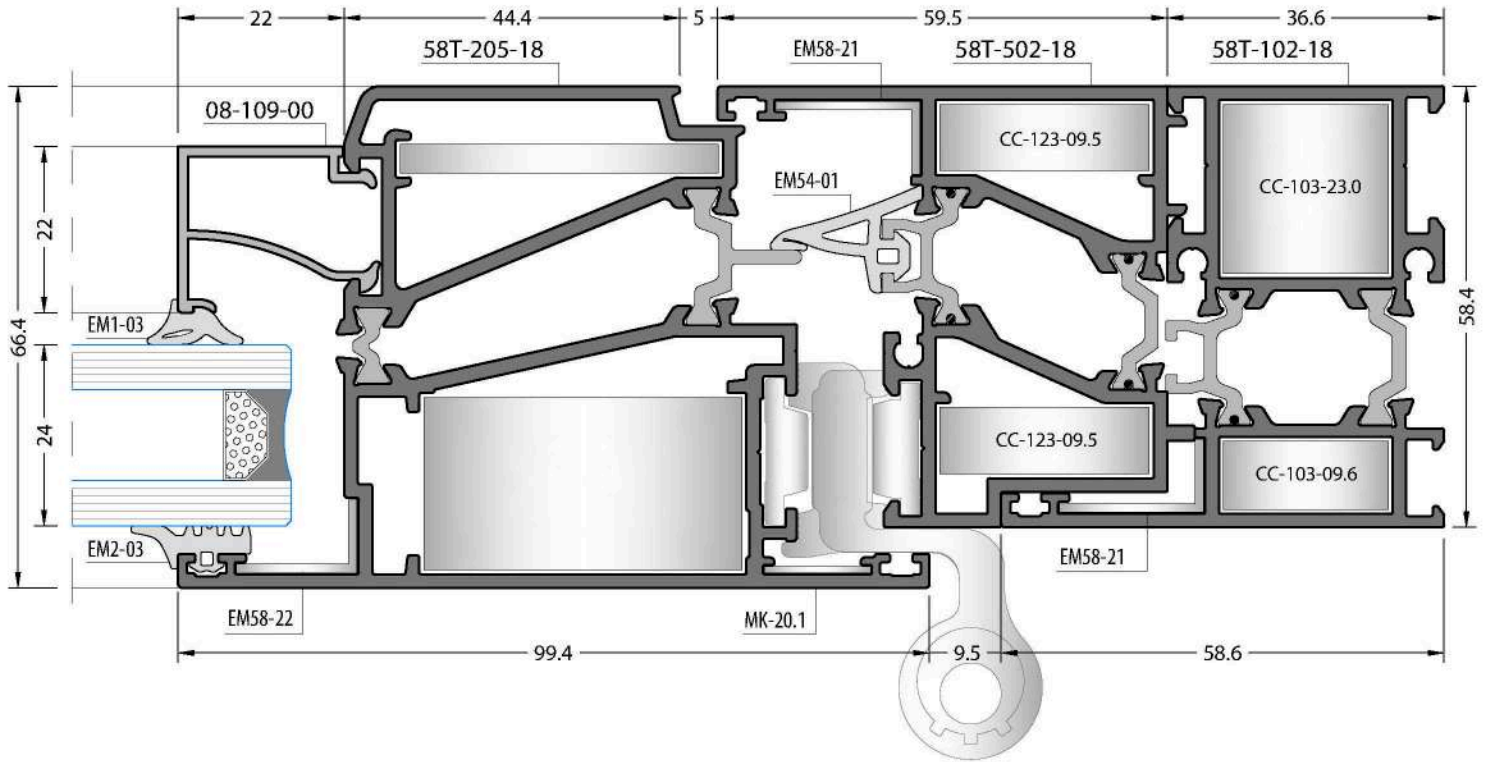

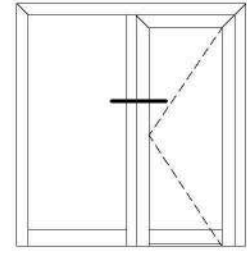

Inside Opening Door
İçe Açılır Kapı

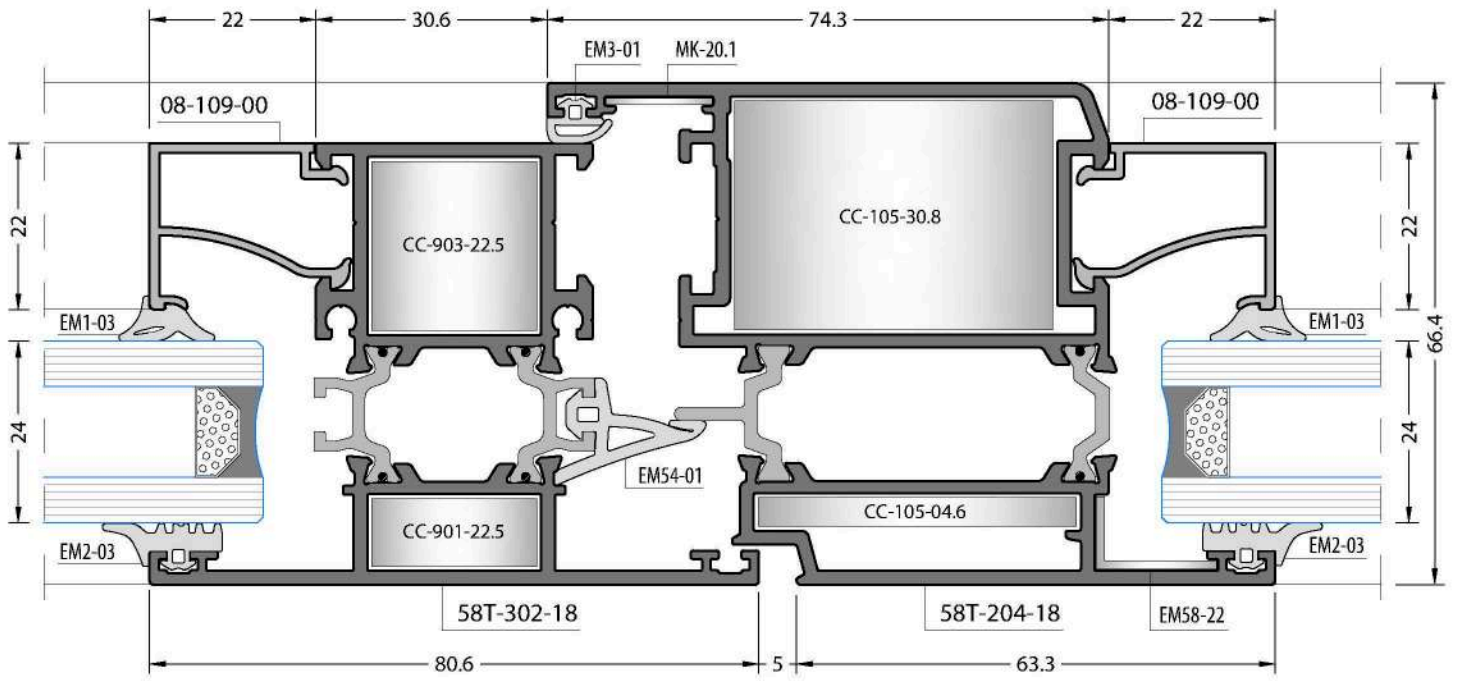

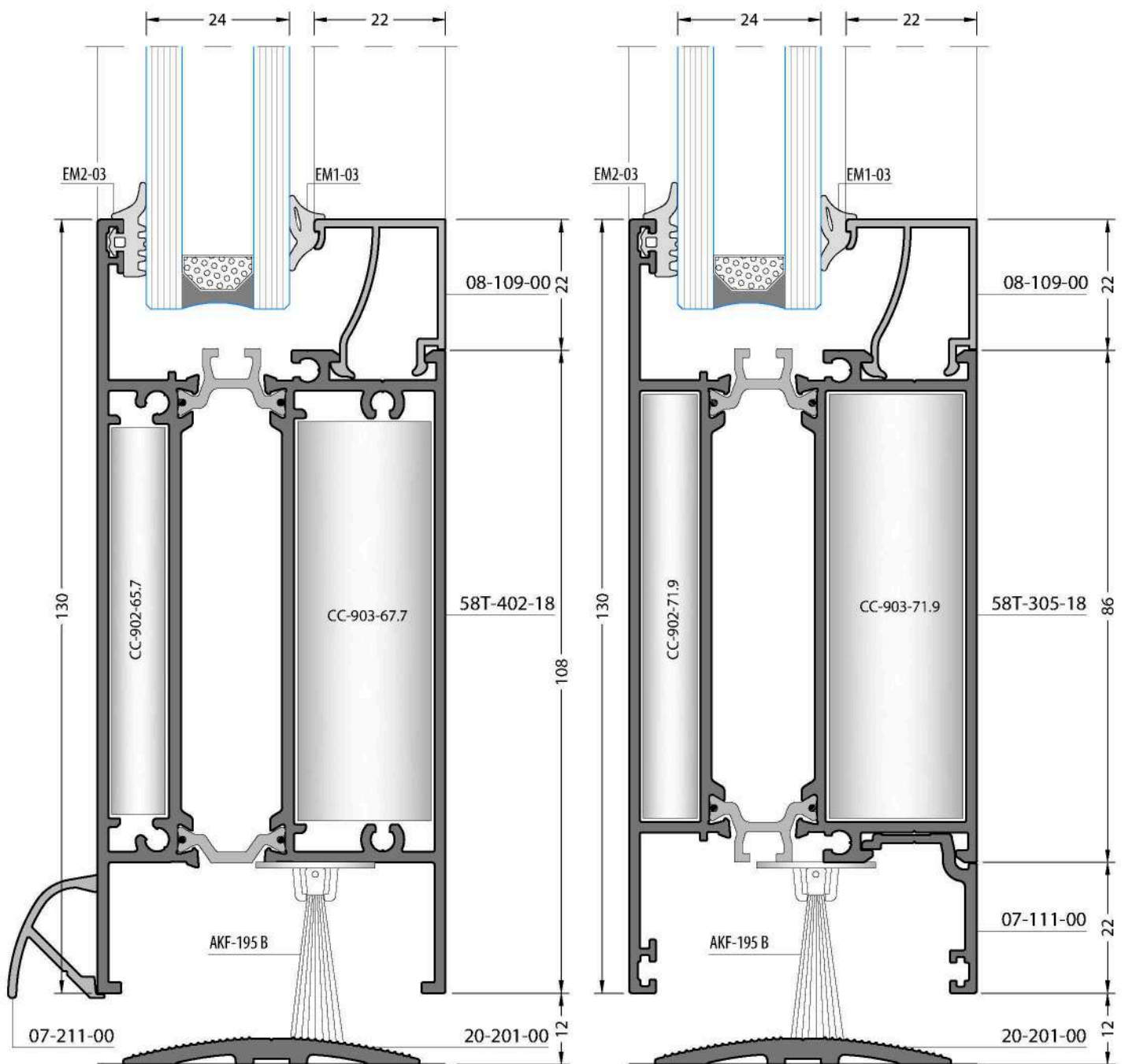
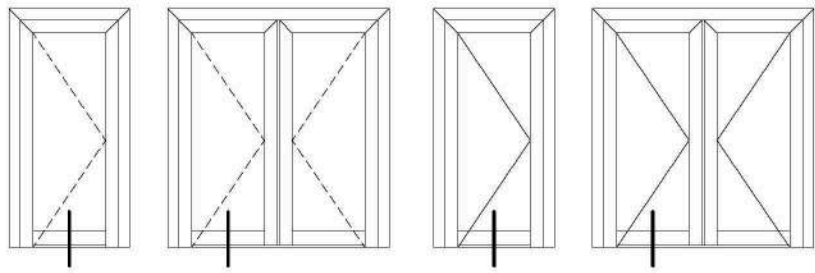

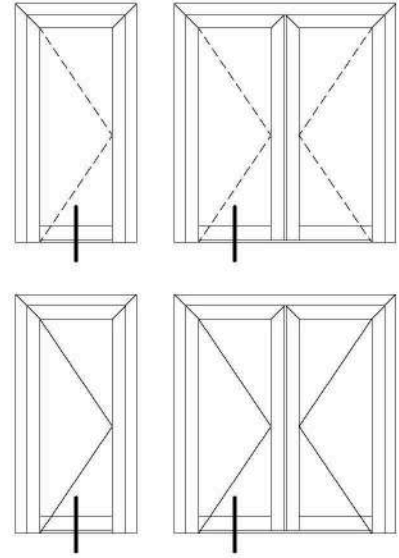
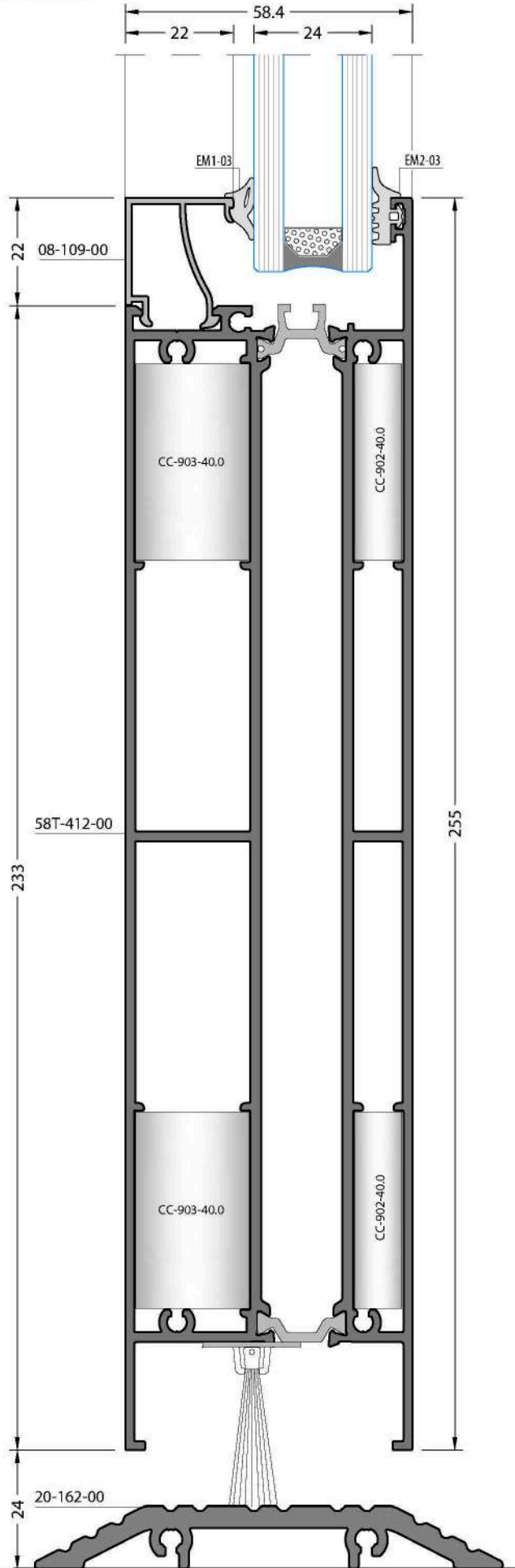

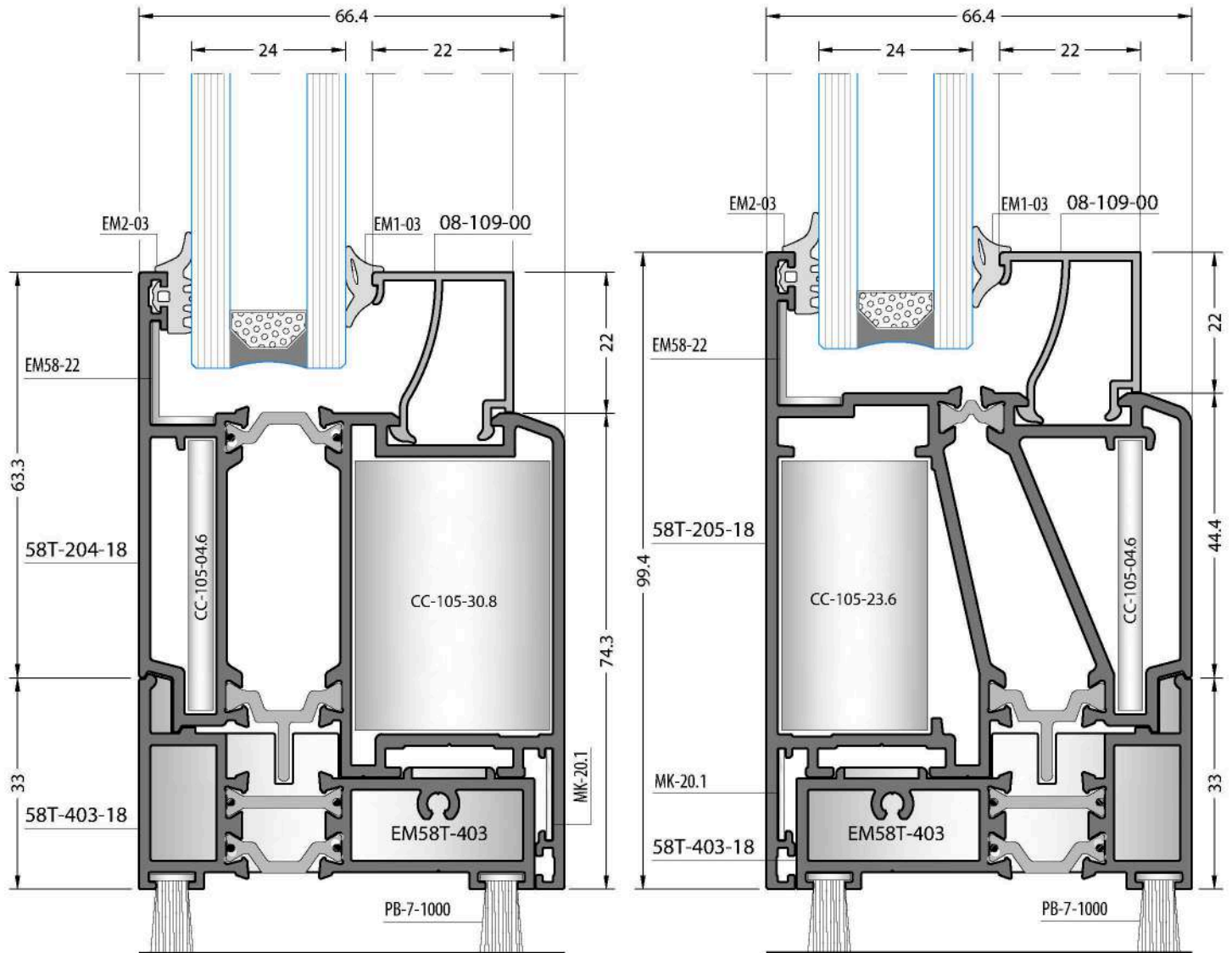
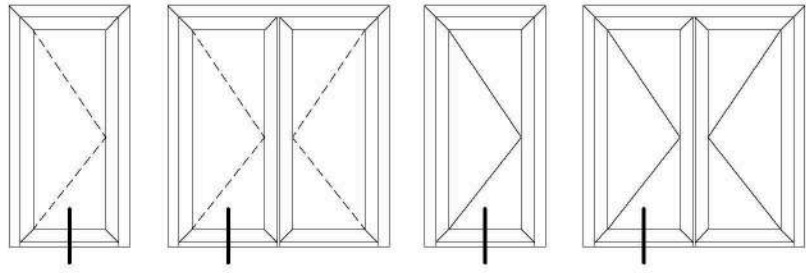

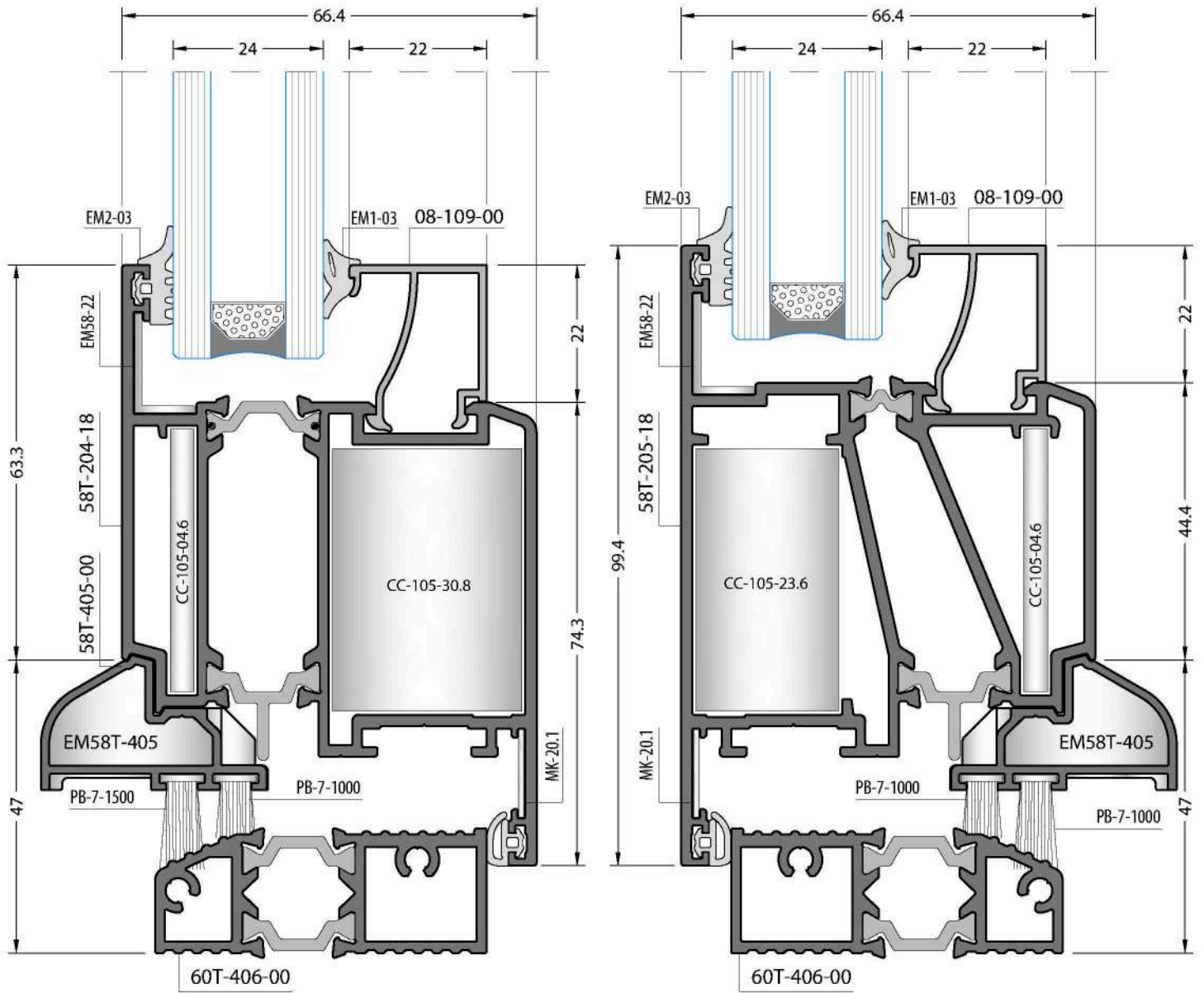
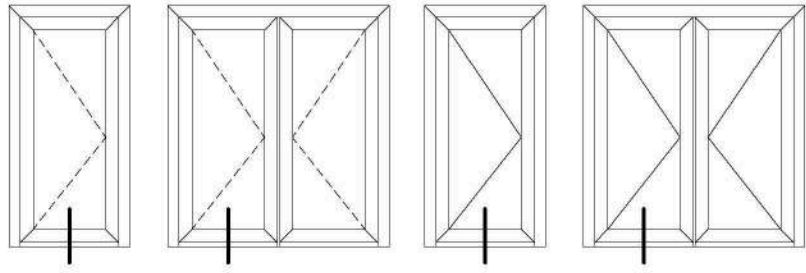

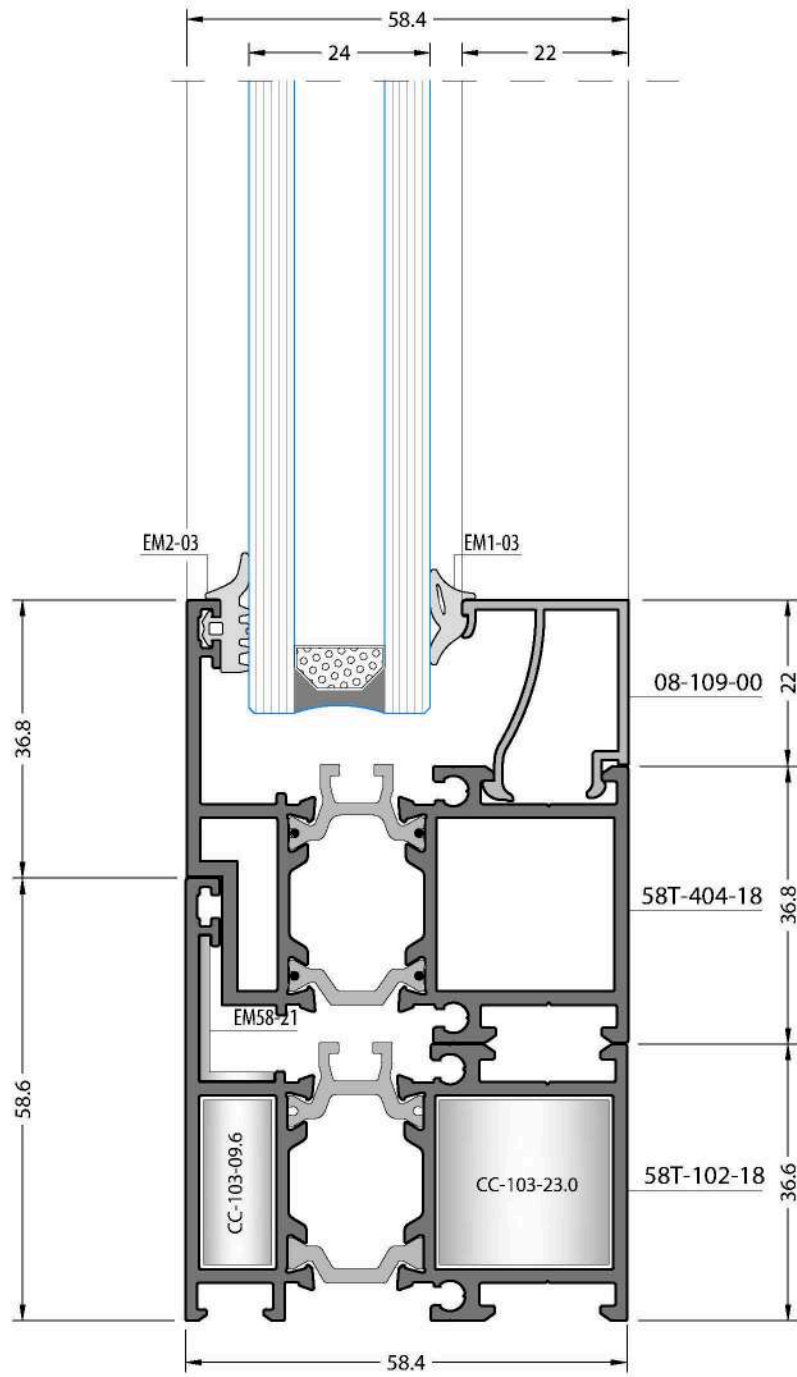
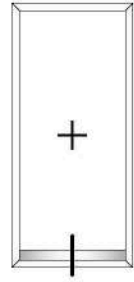

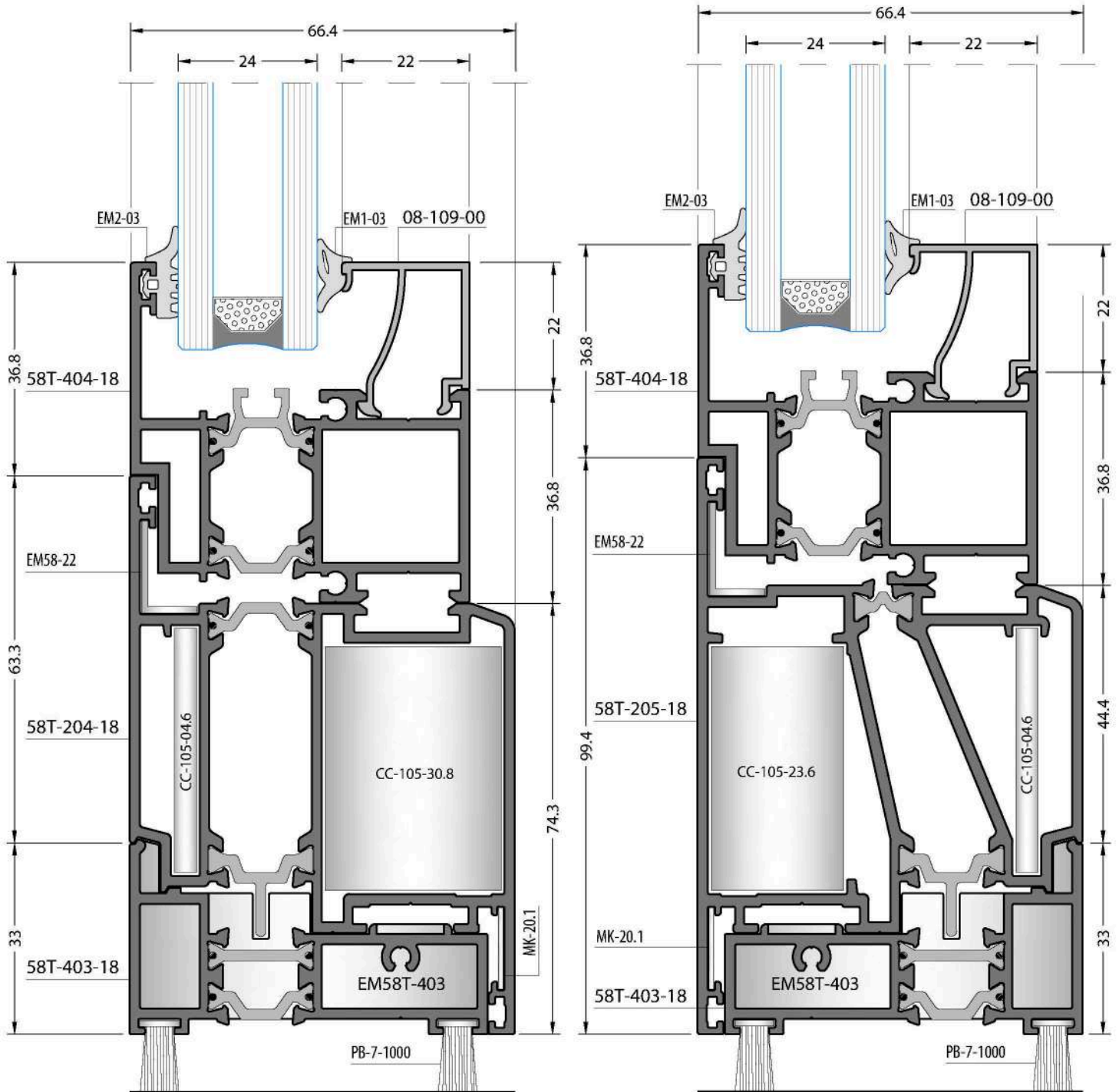
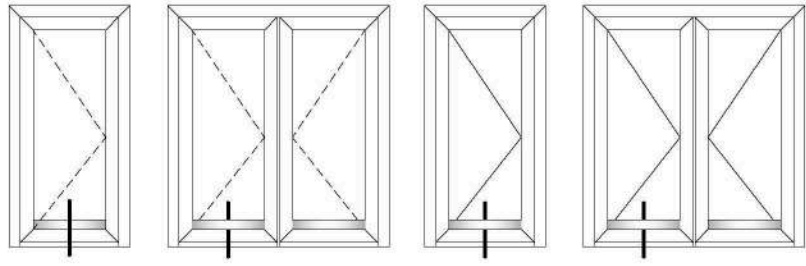

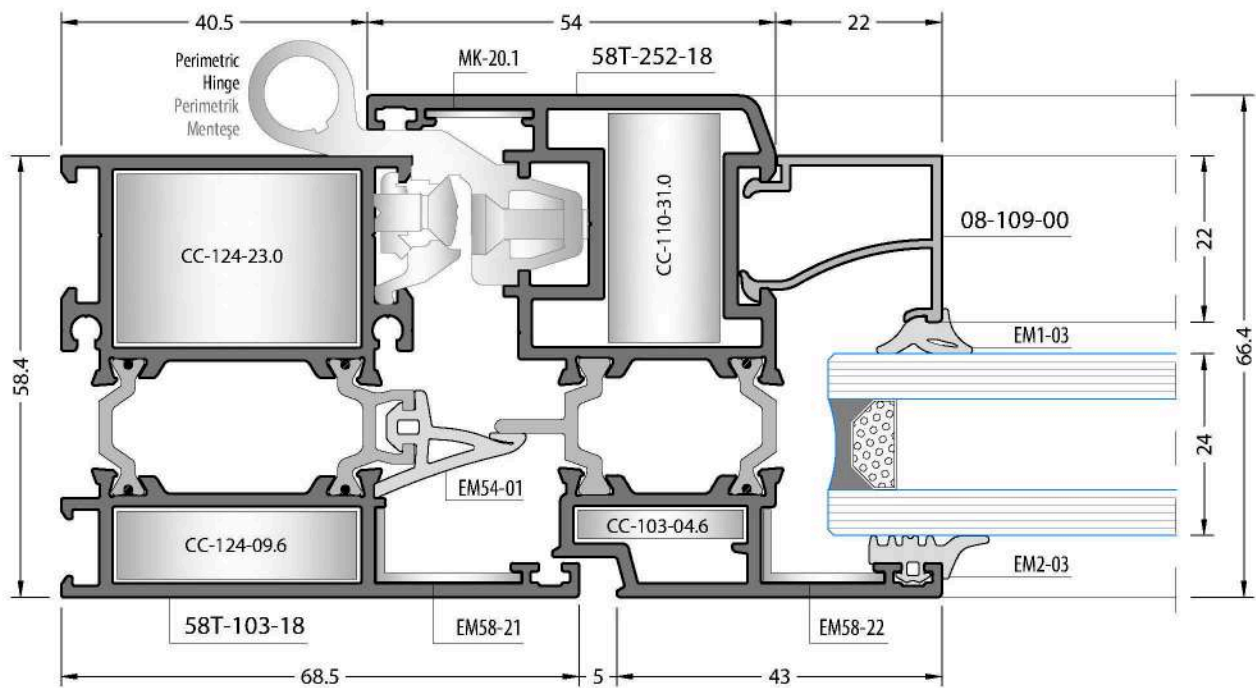
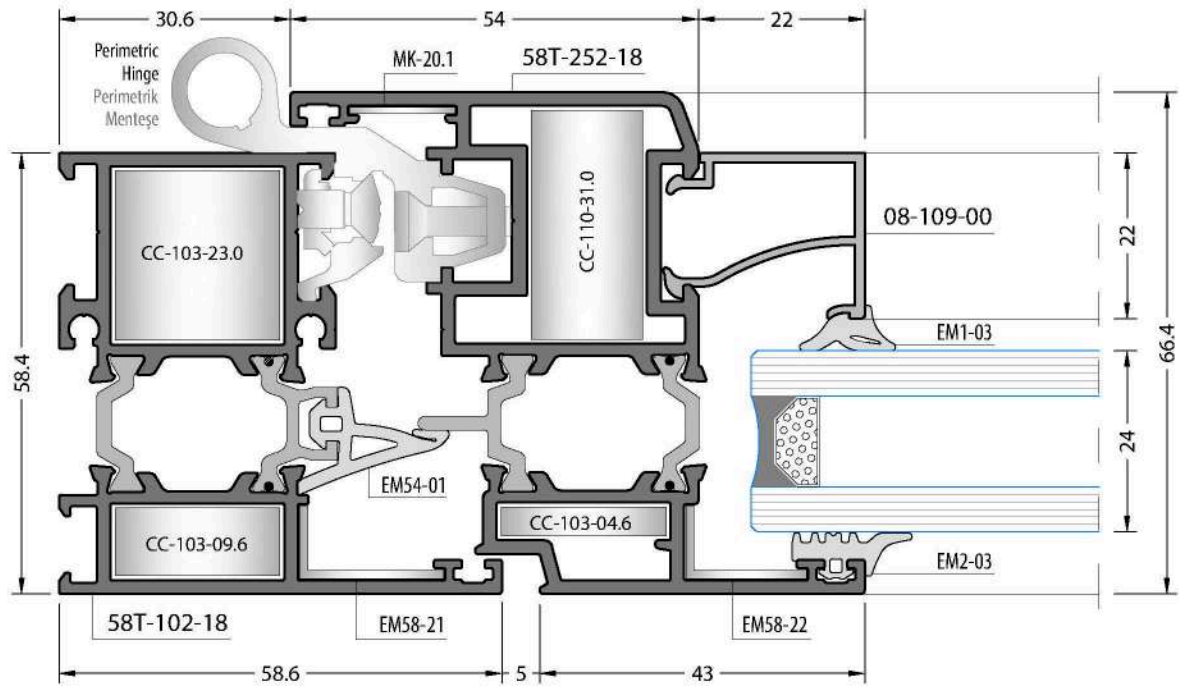
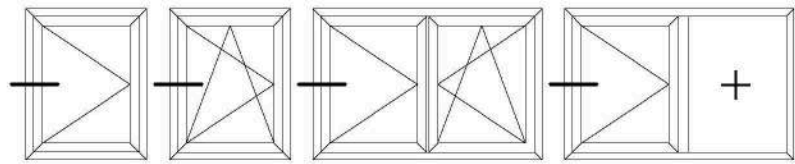

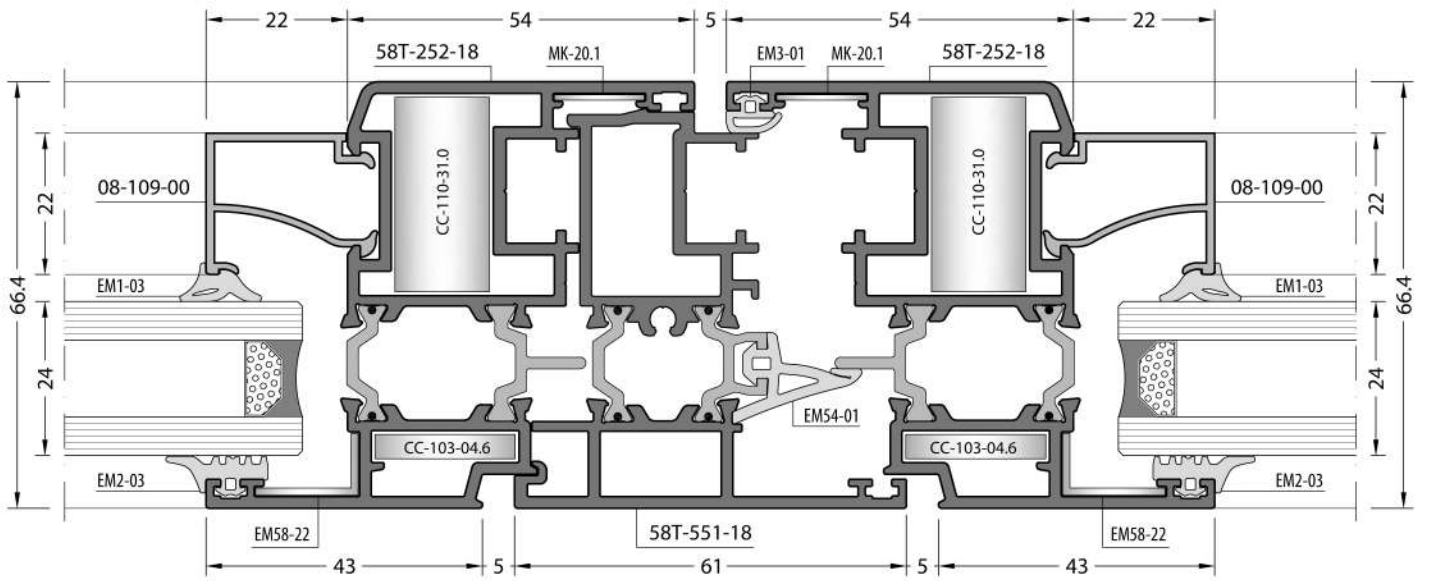
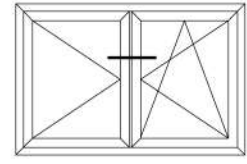

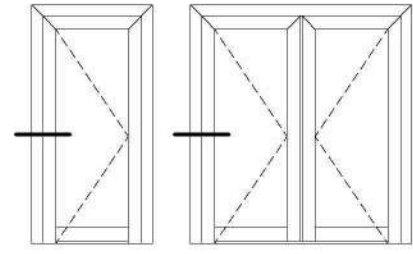

Inside Opening Door
İçe Açılır Kapı

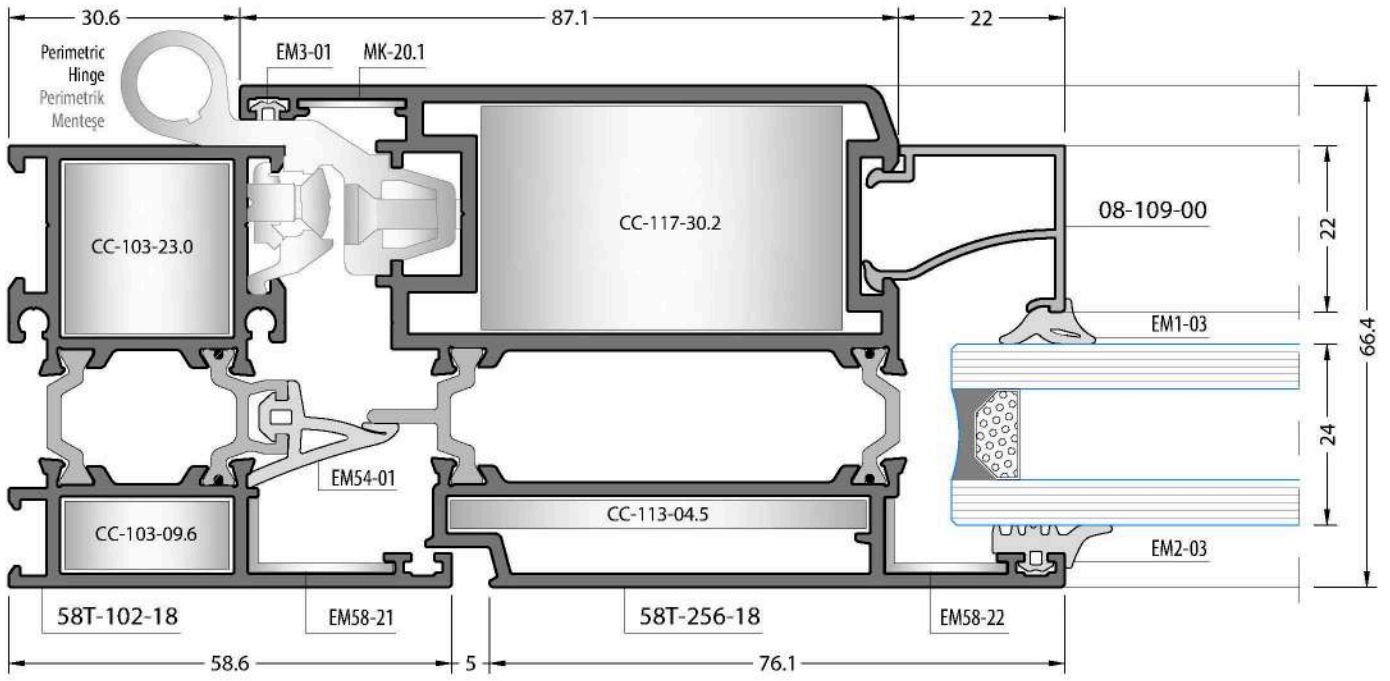

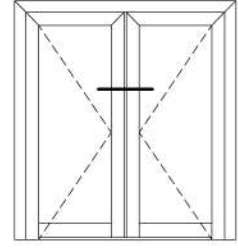

Inside Opening Door
İçe Açılır Kapı

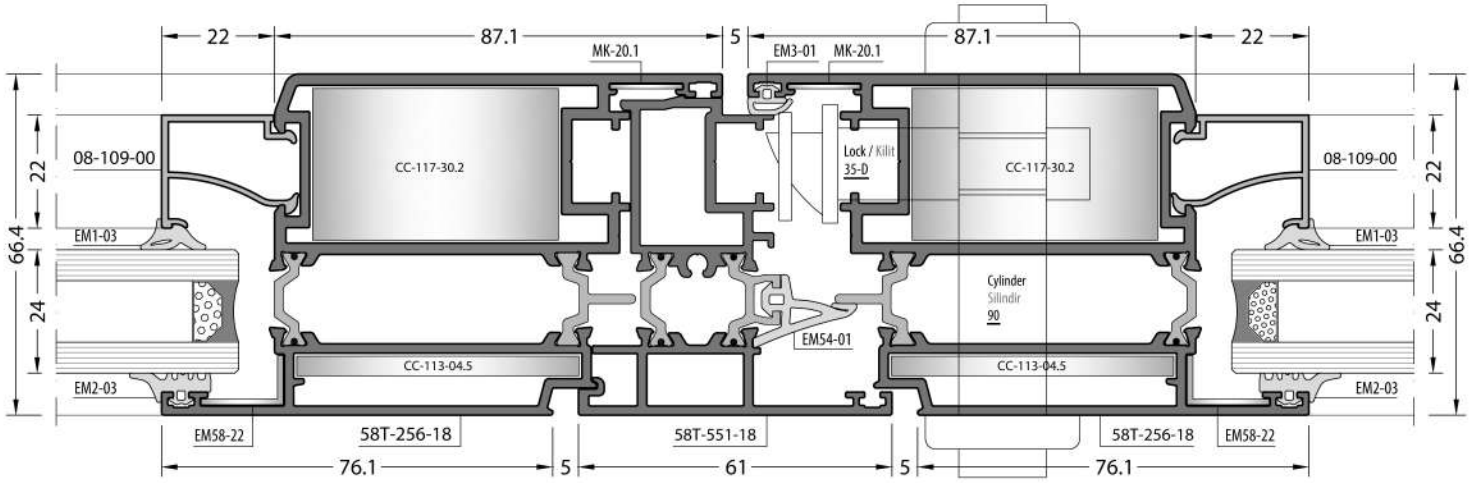

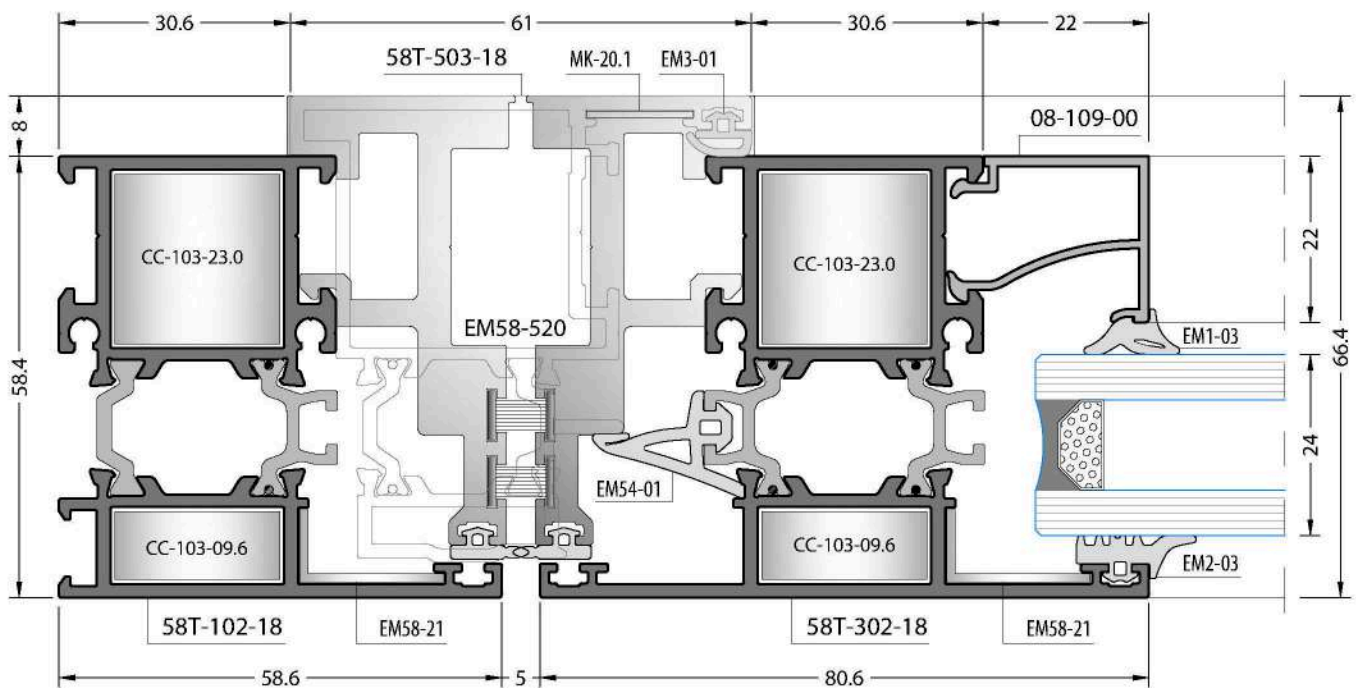
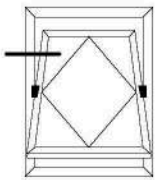
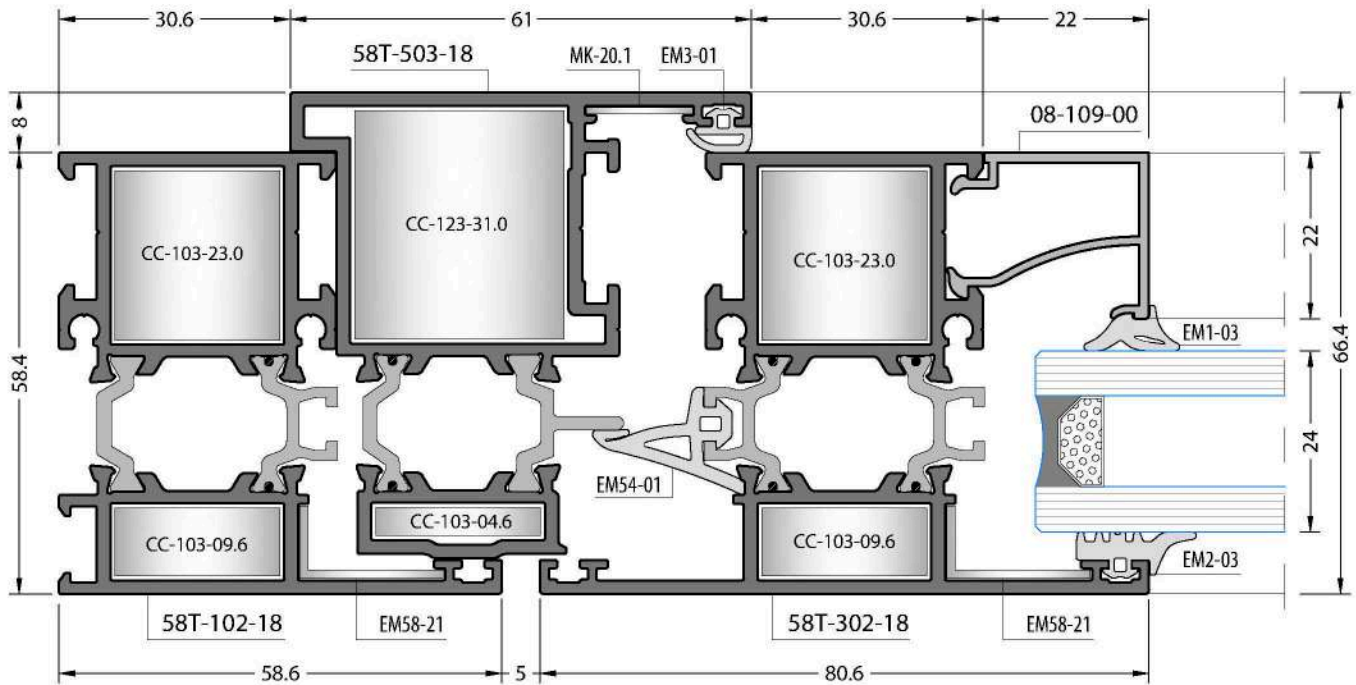
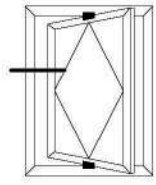

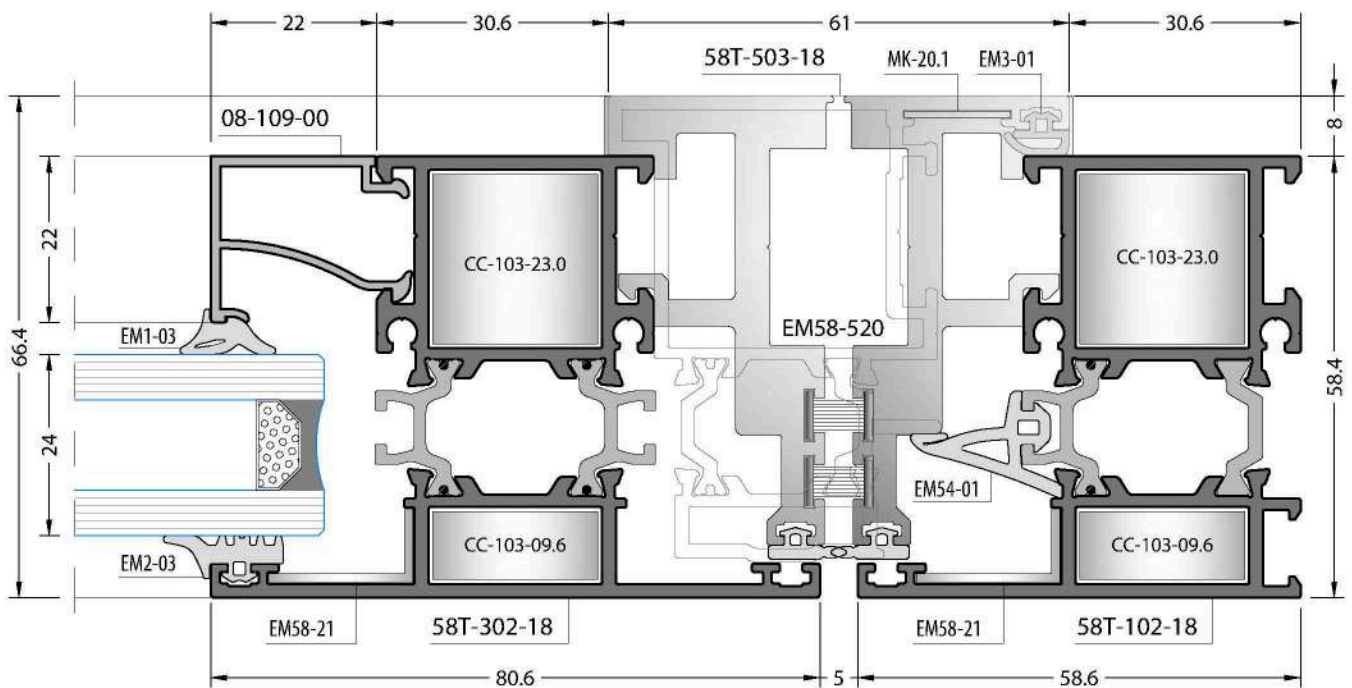
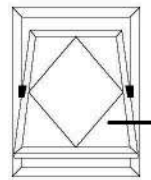
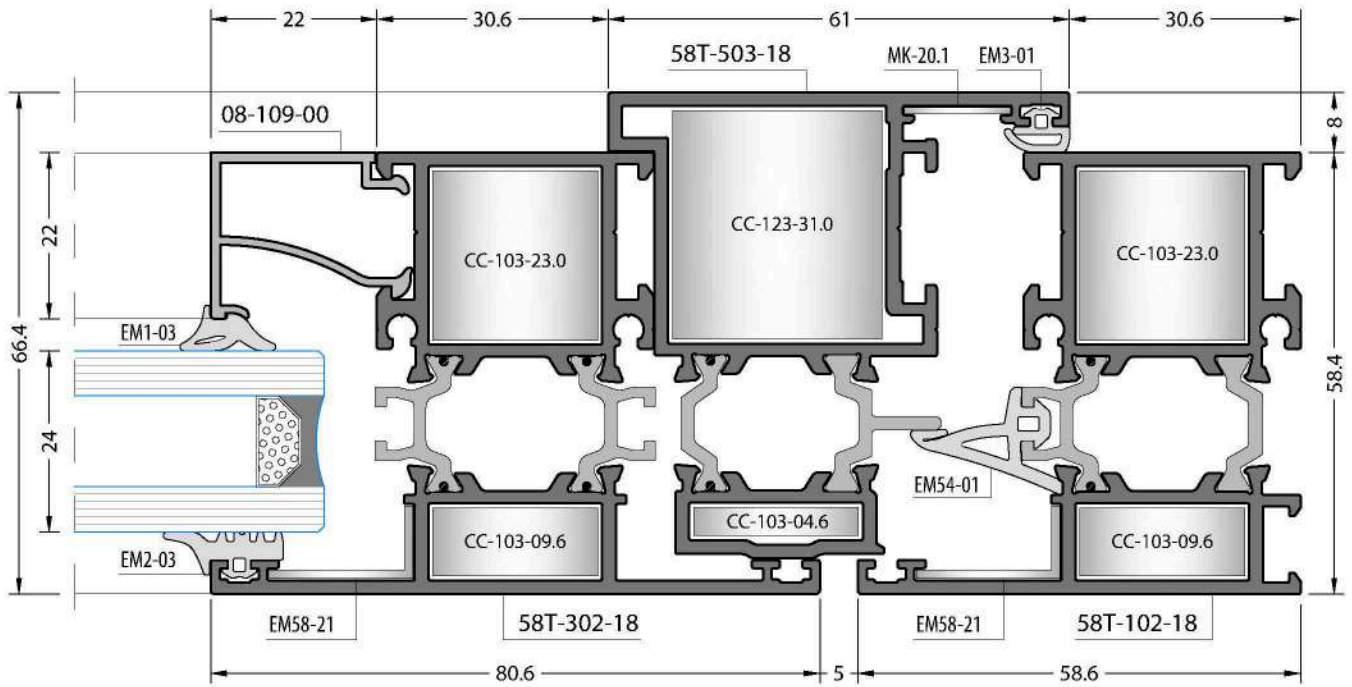
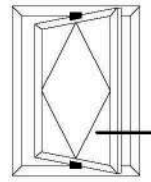

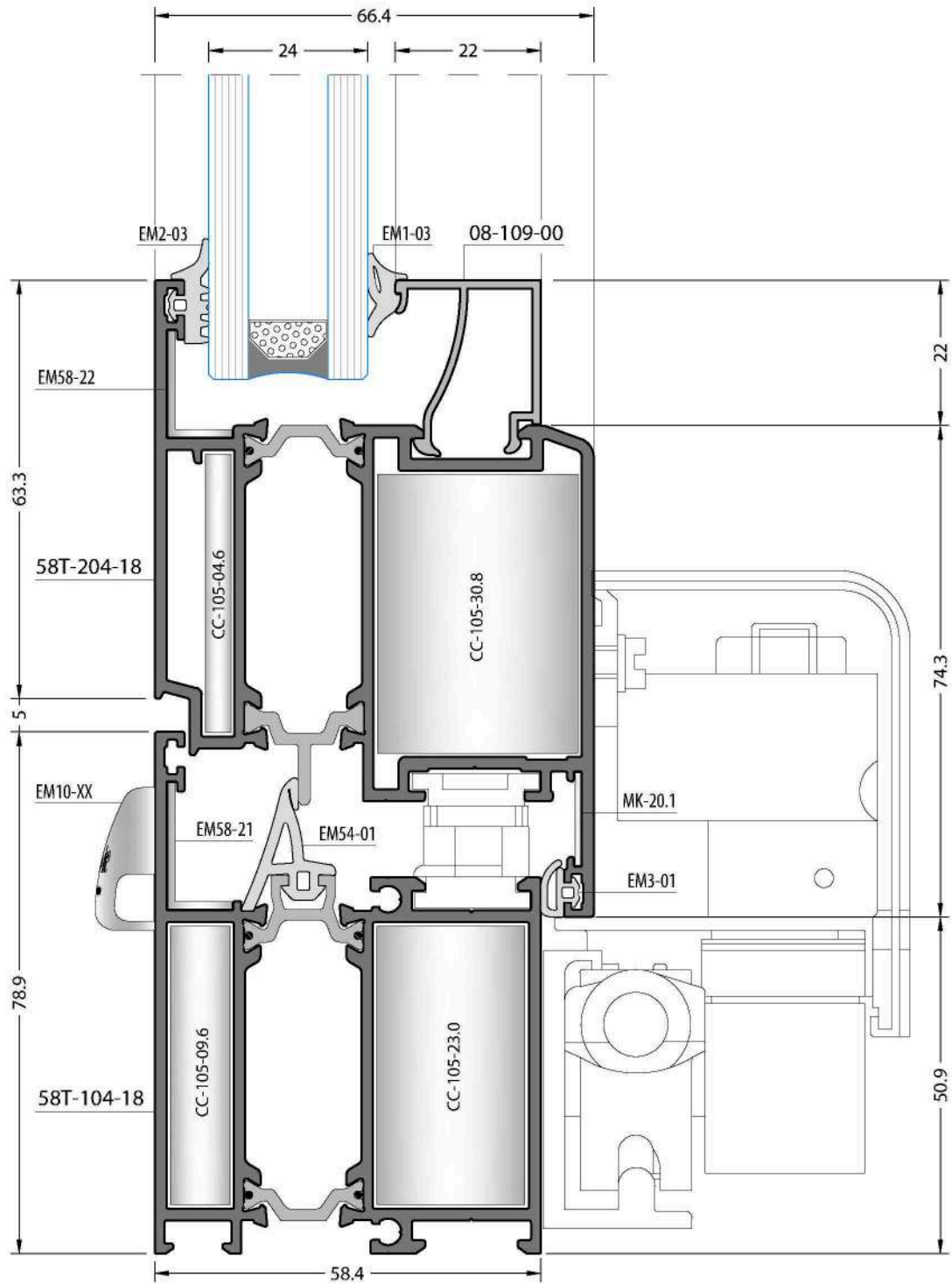
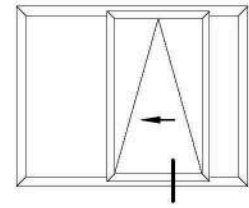

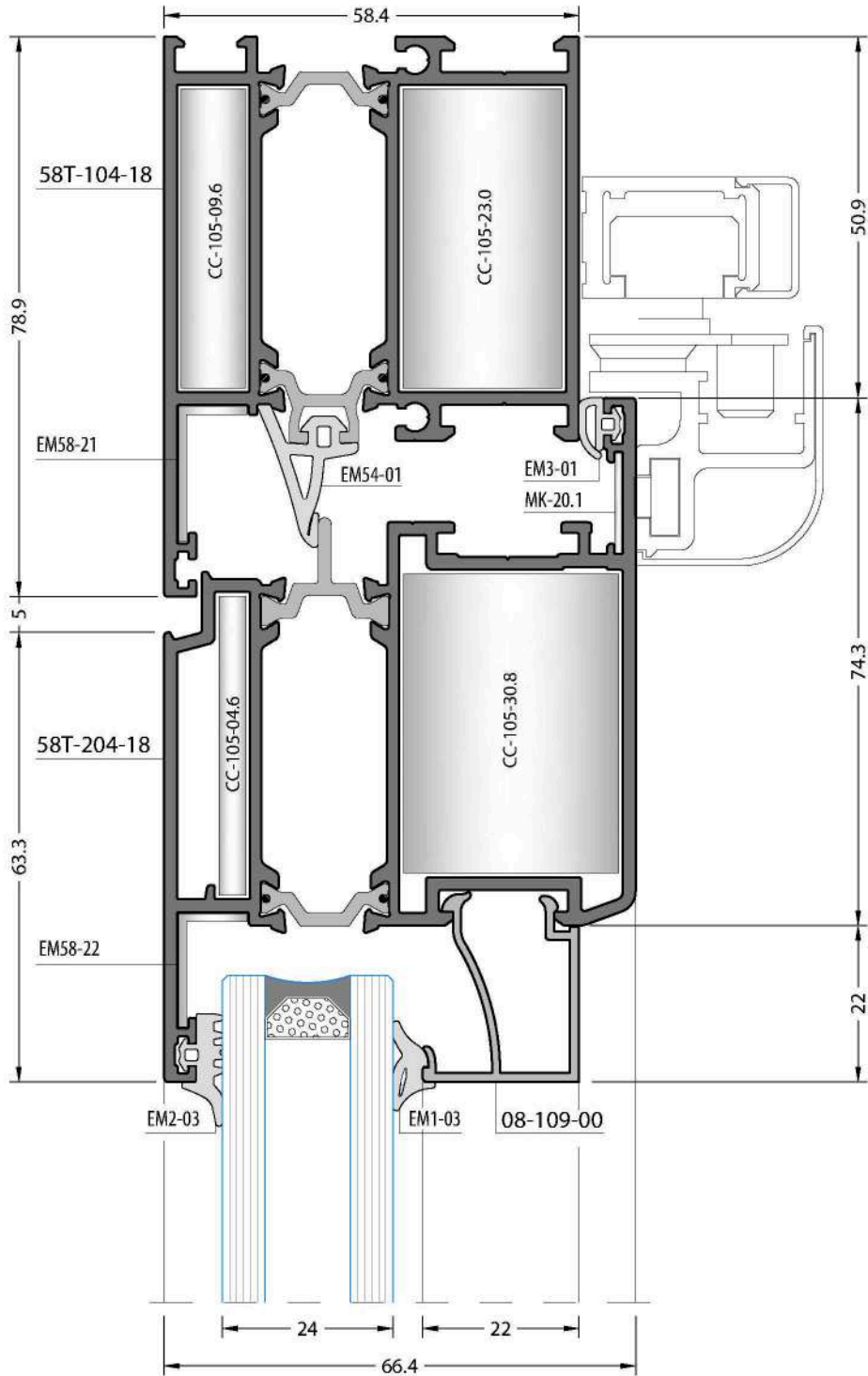
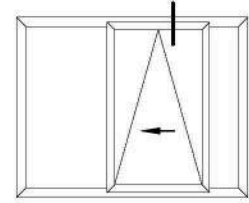

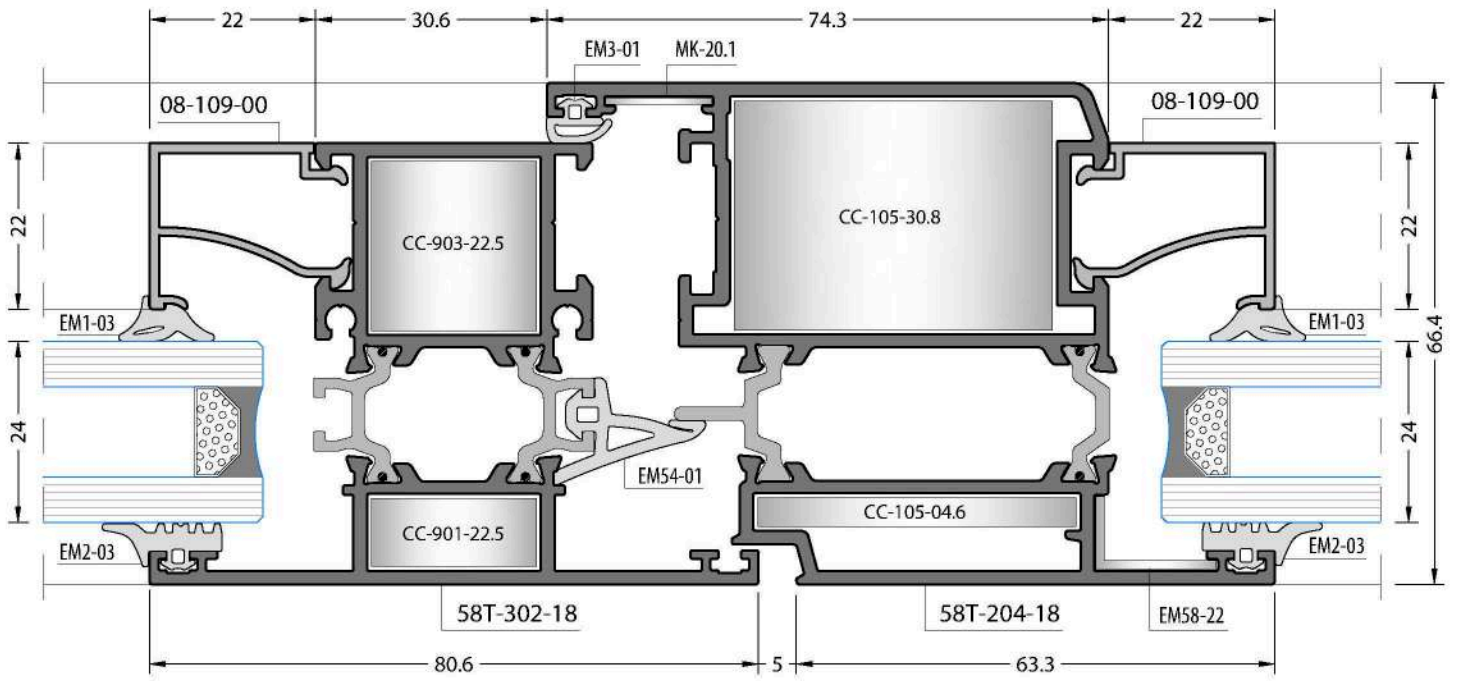
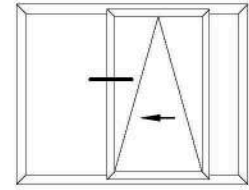

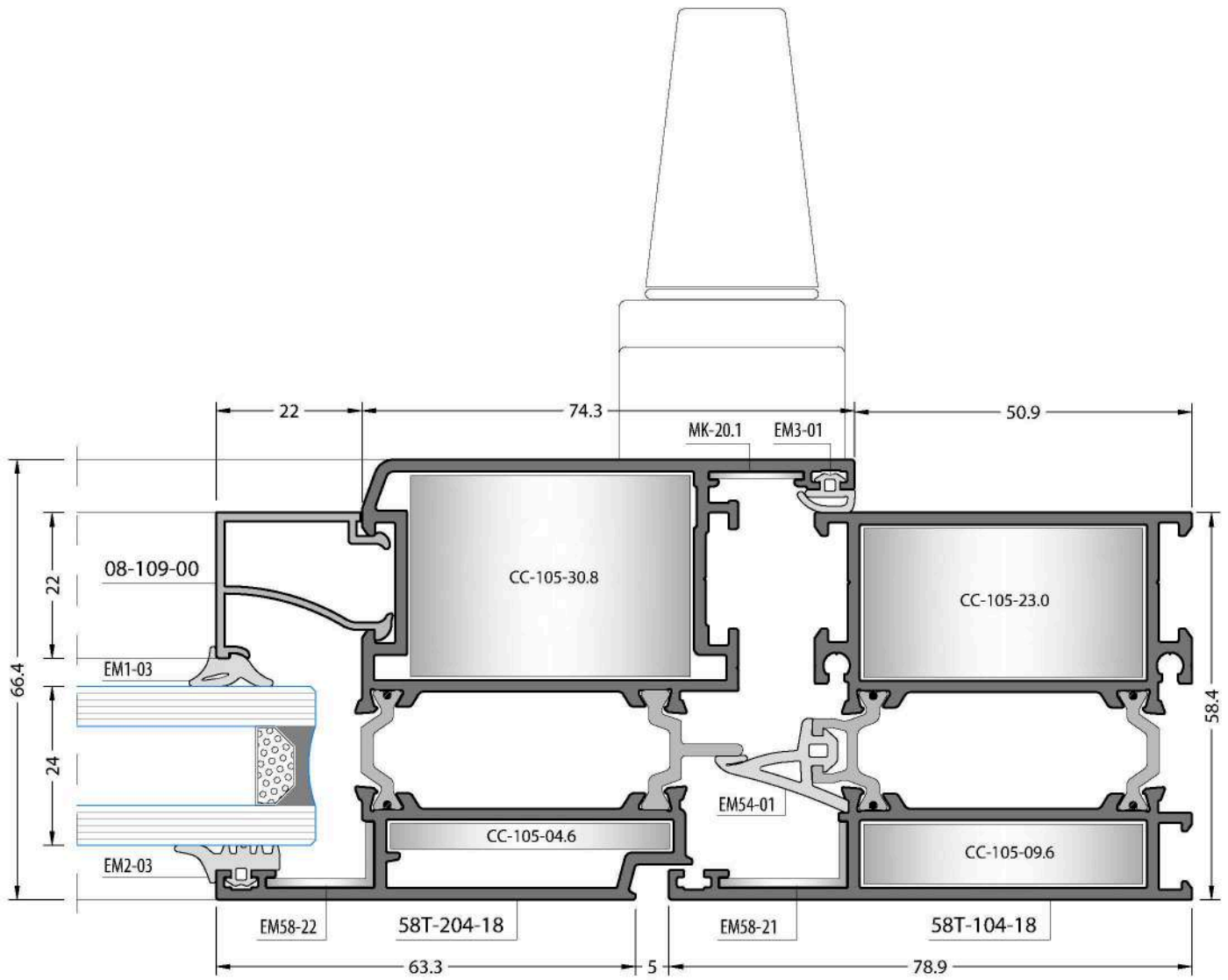
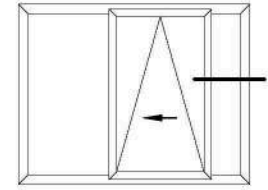

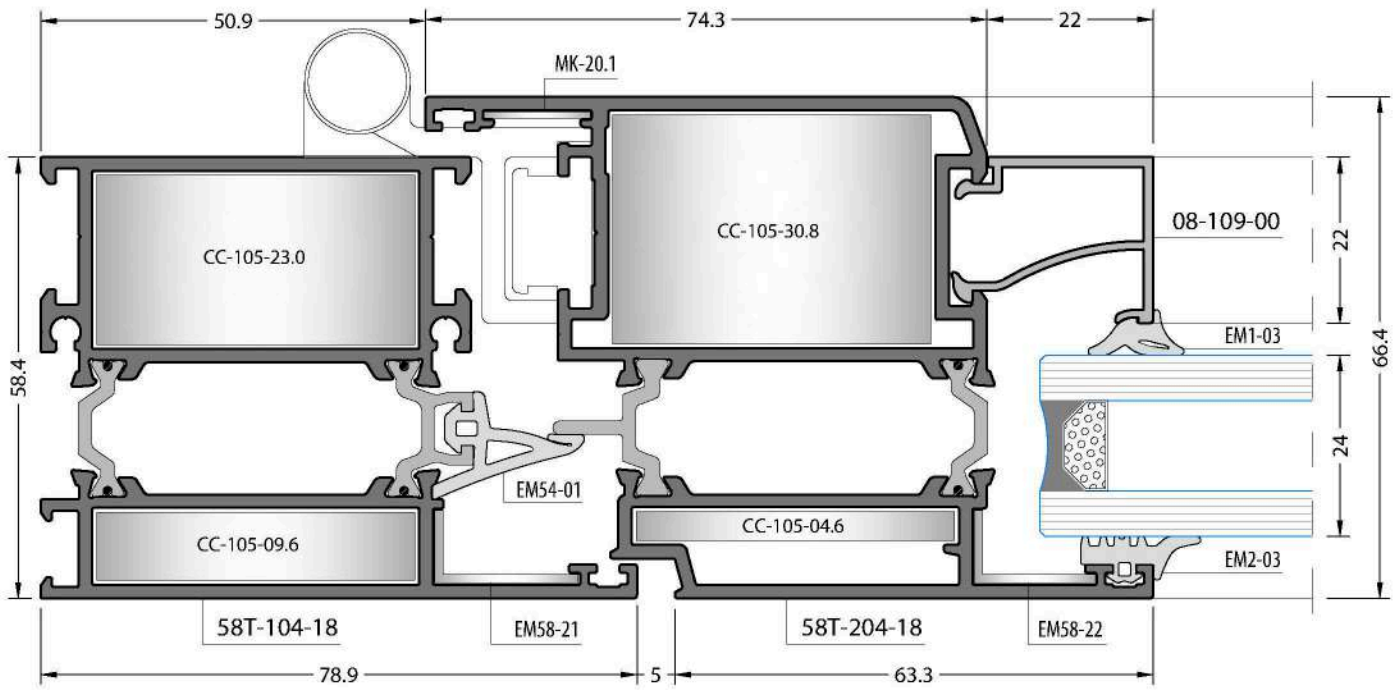
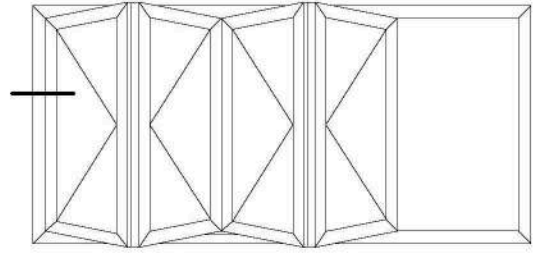

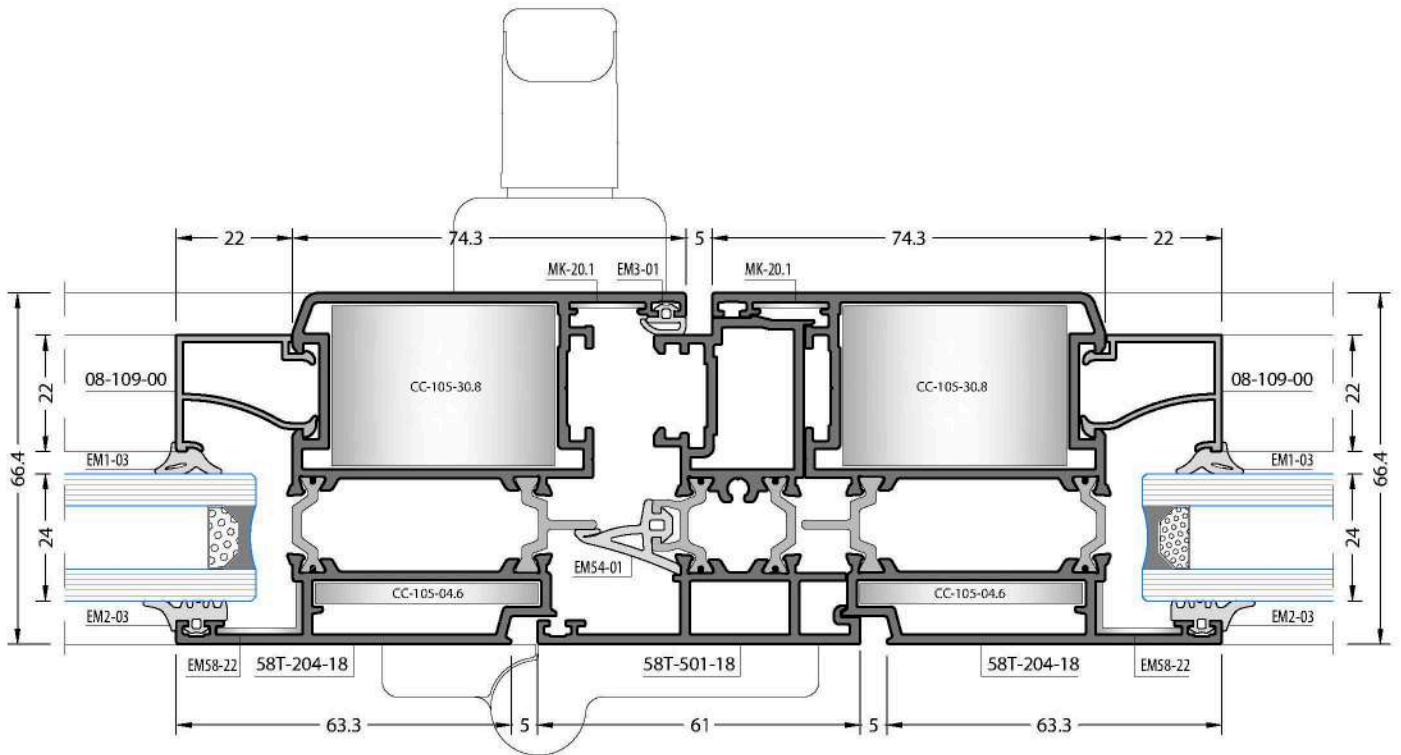
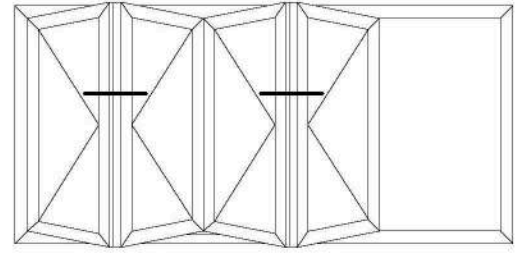

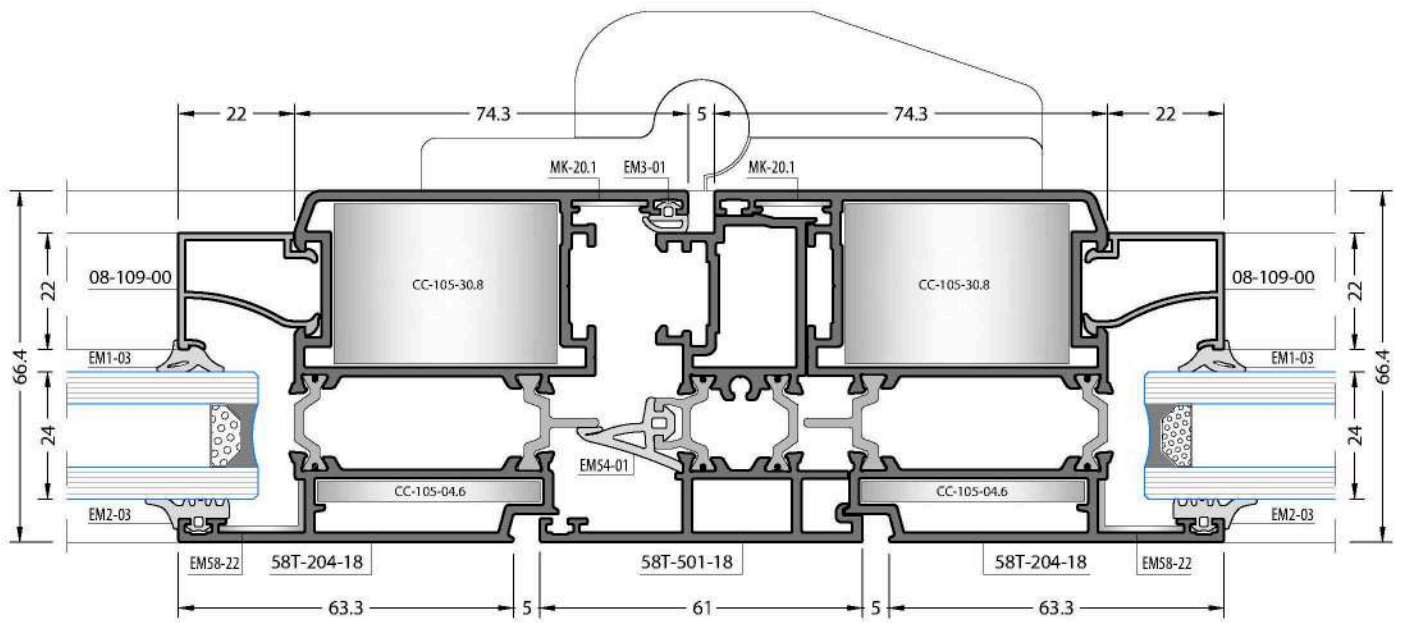
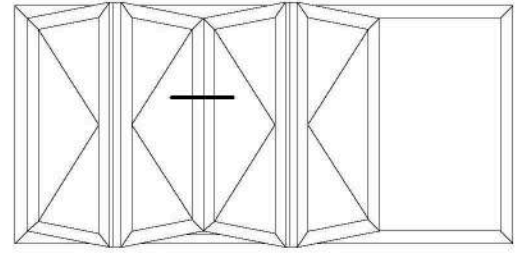

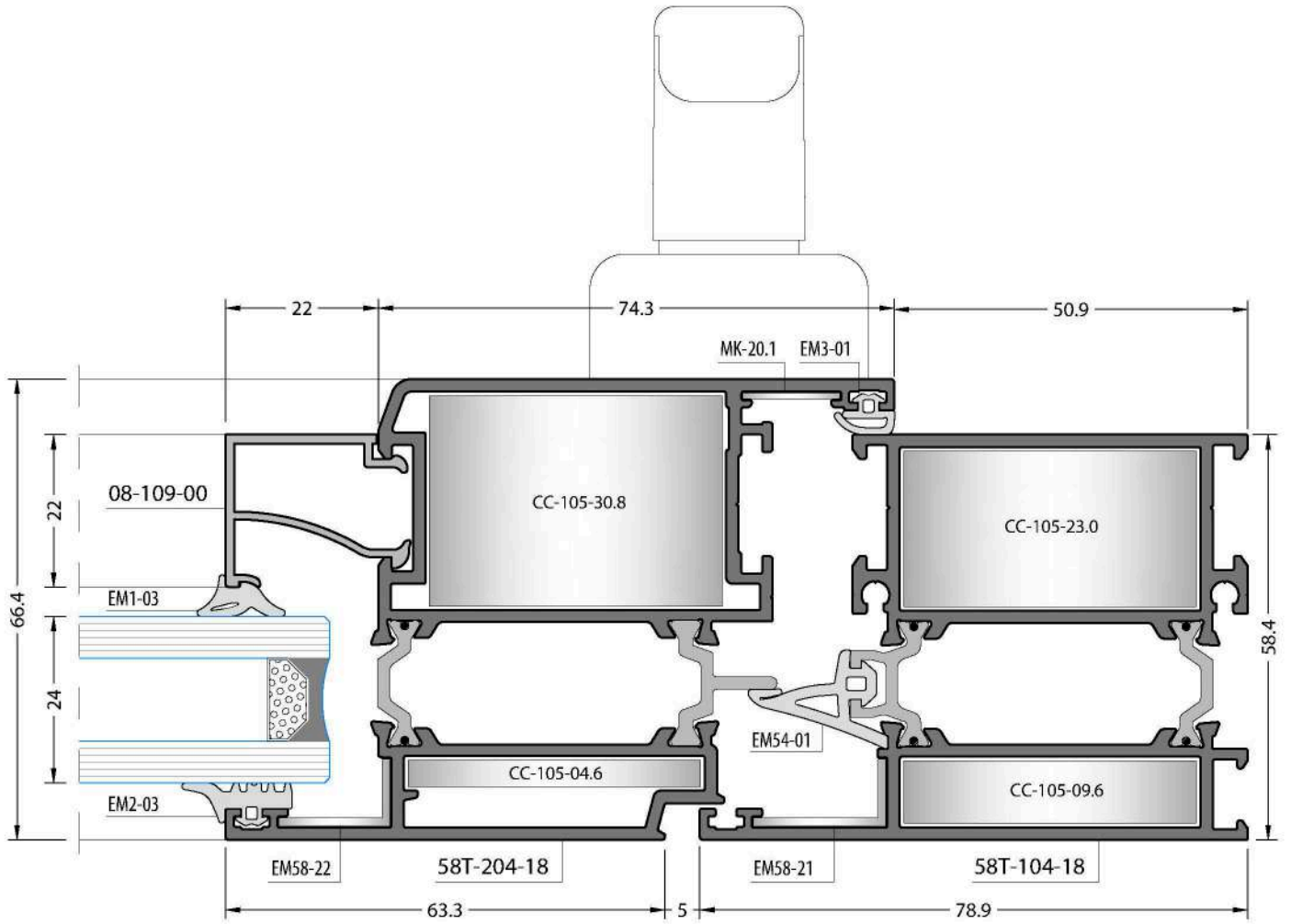
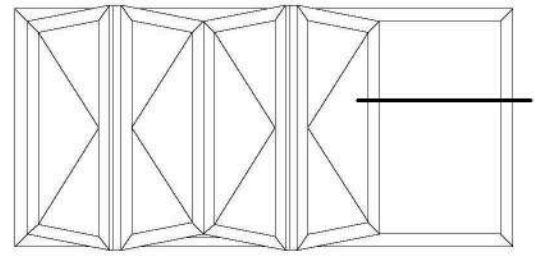

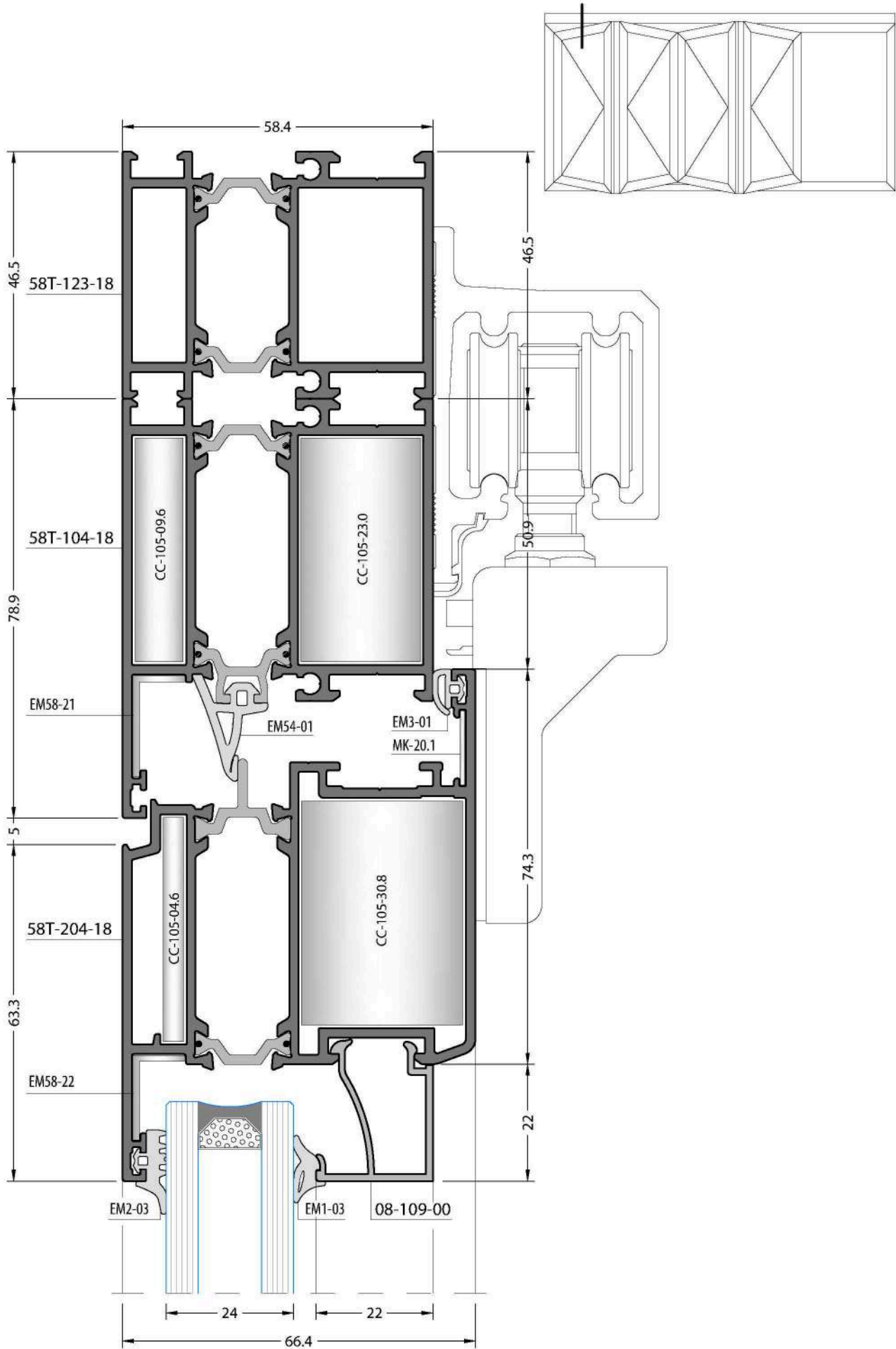

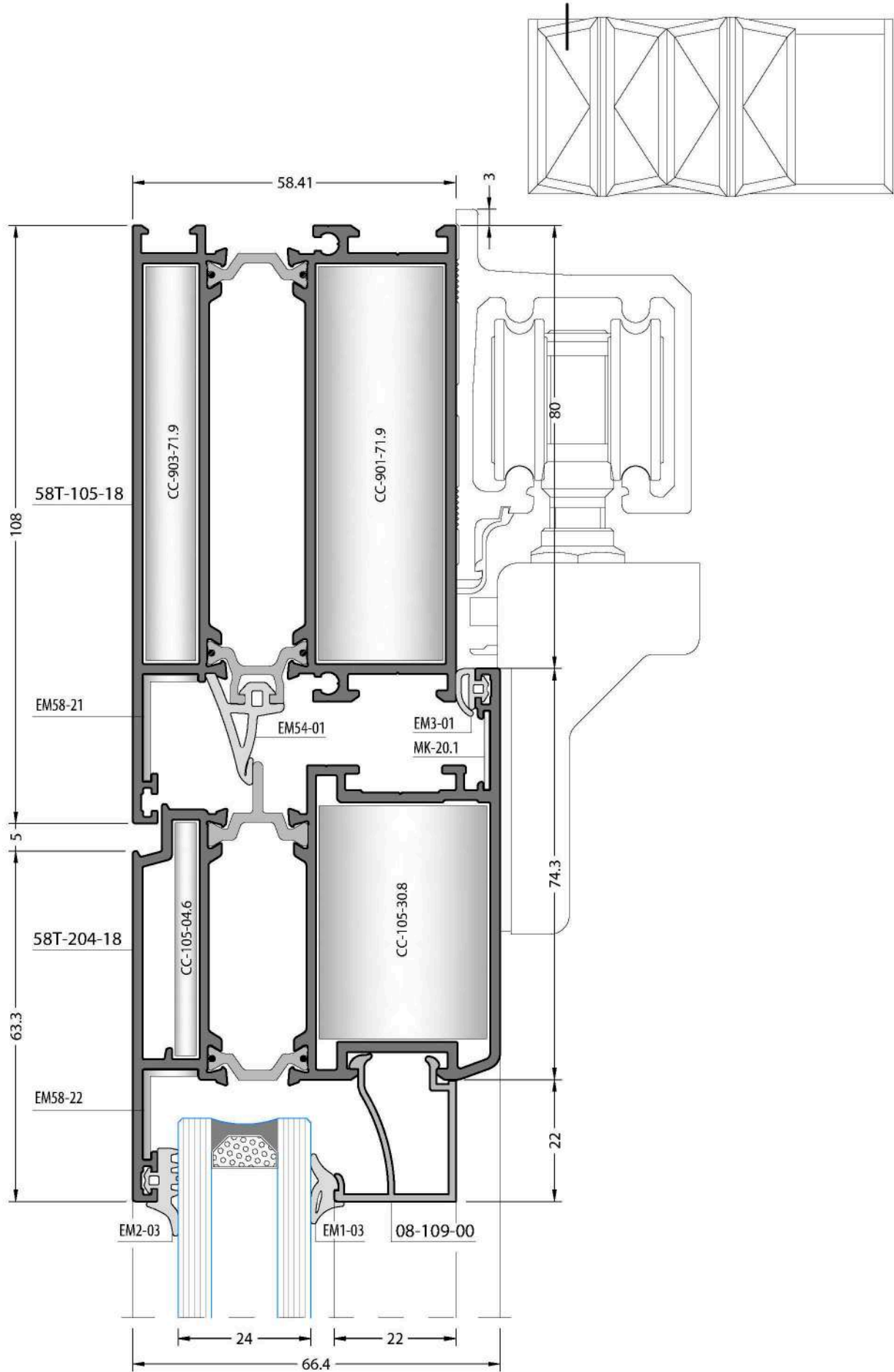

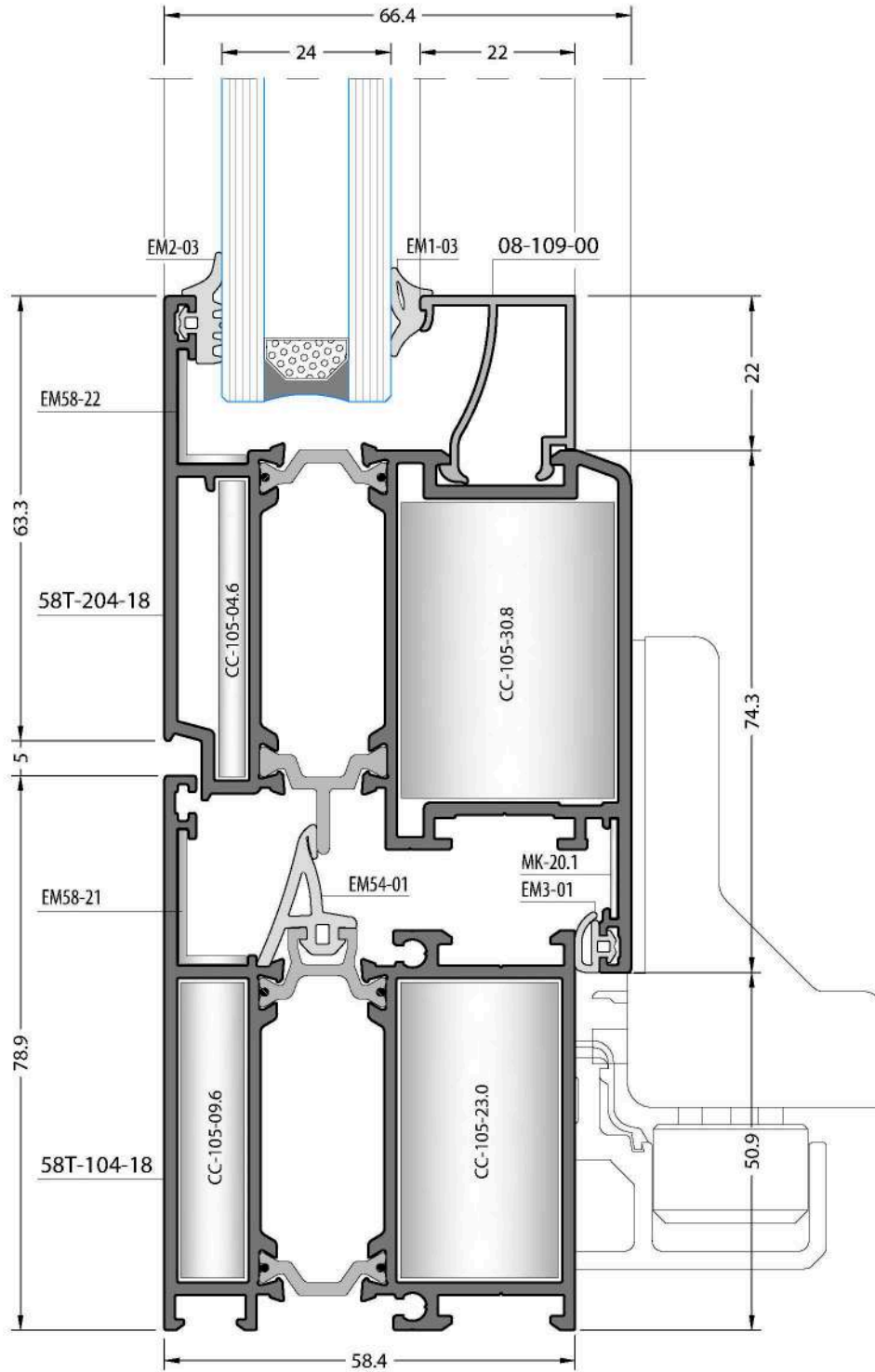
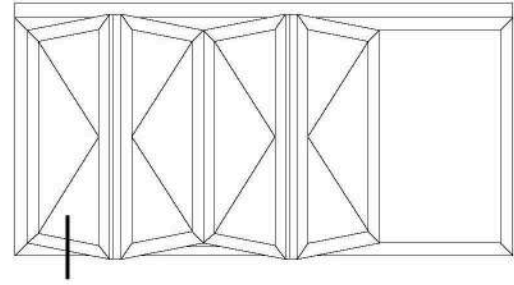

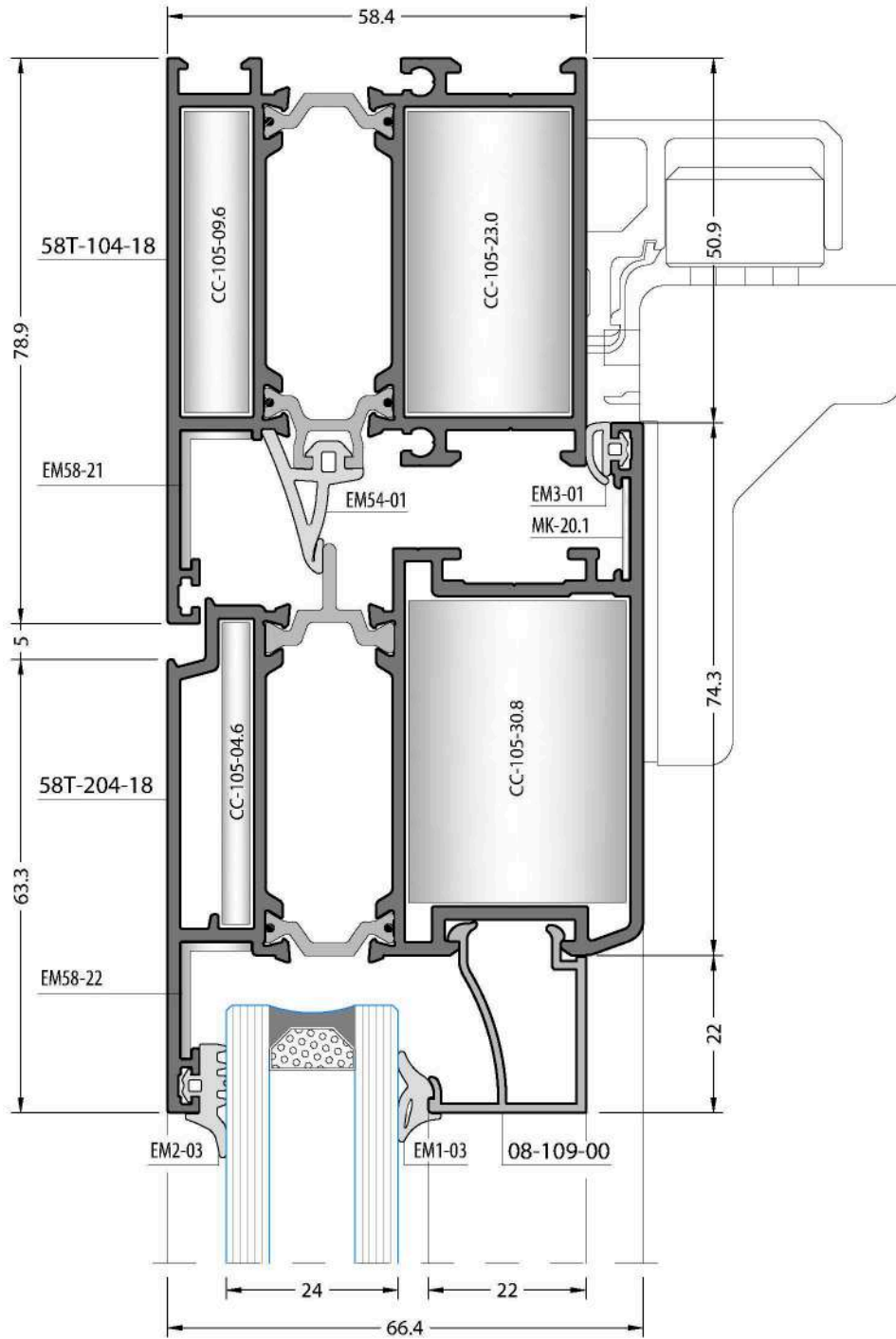
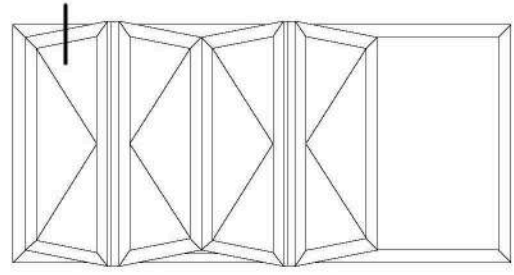

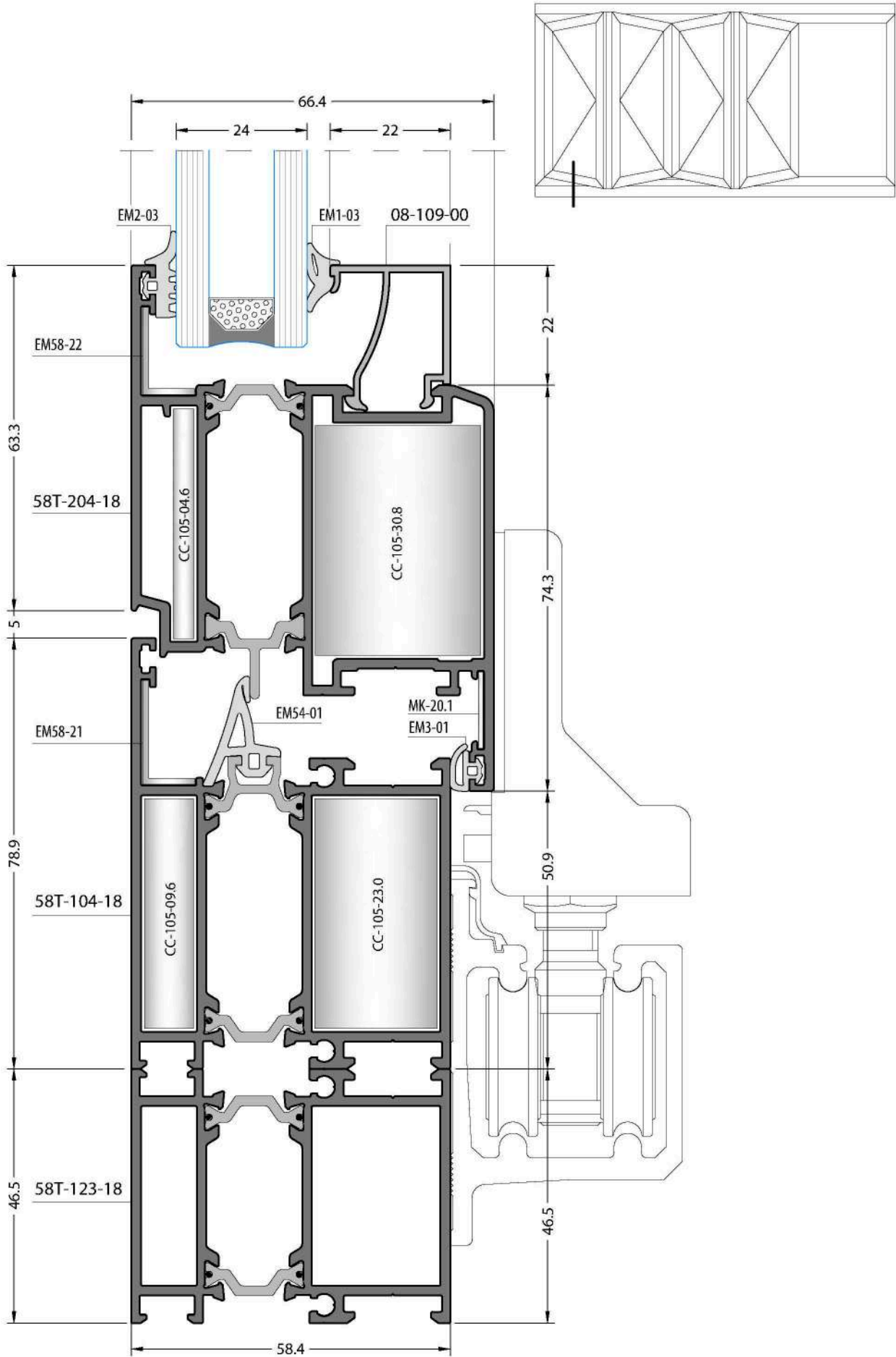

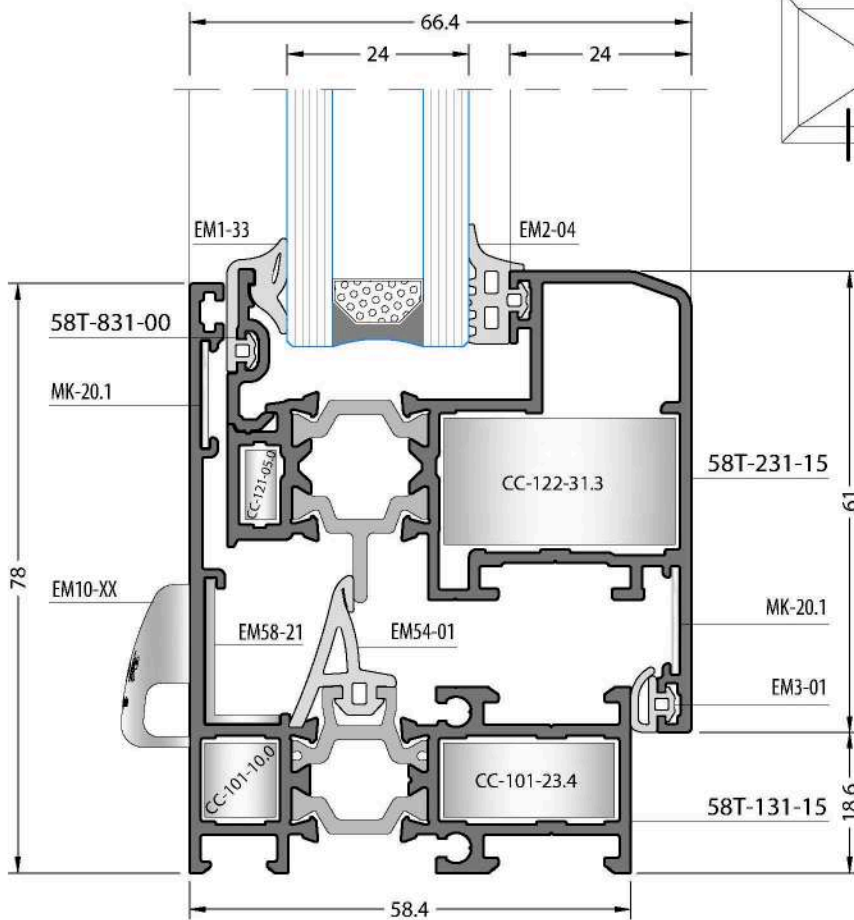
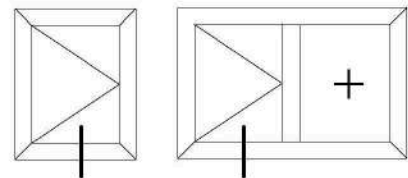
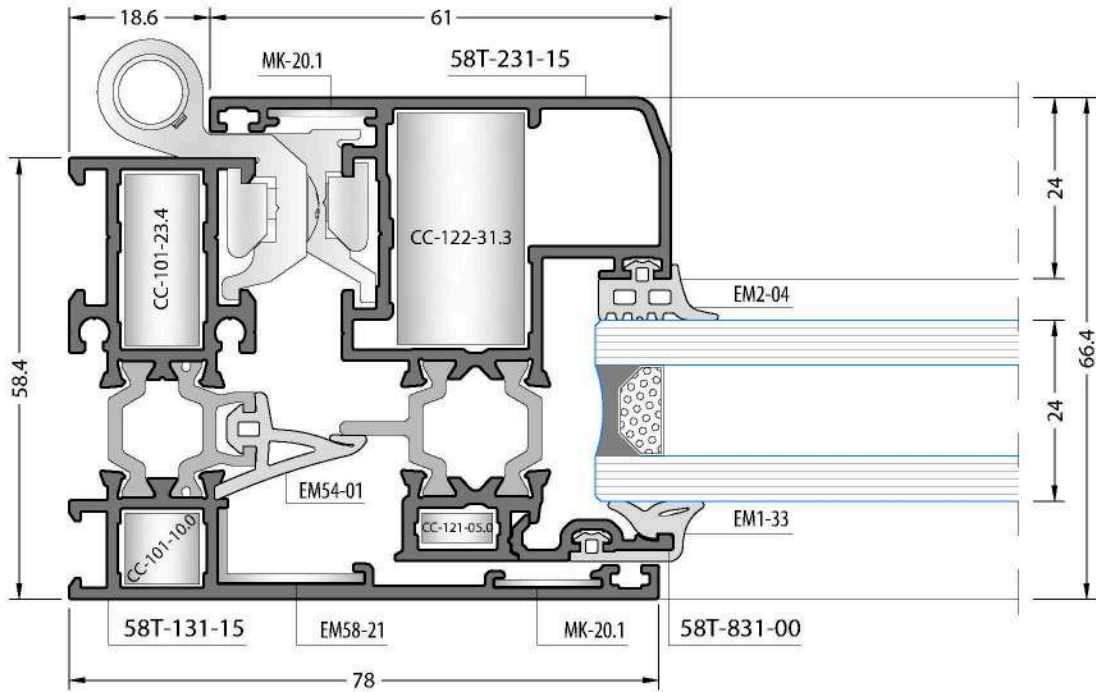
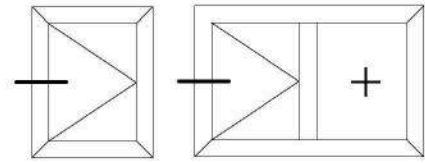

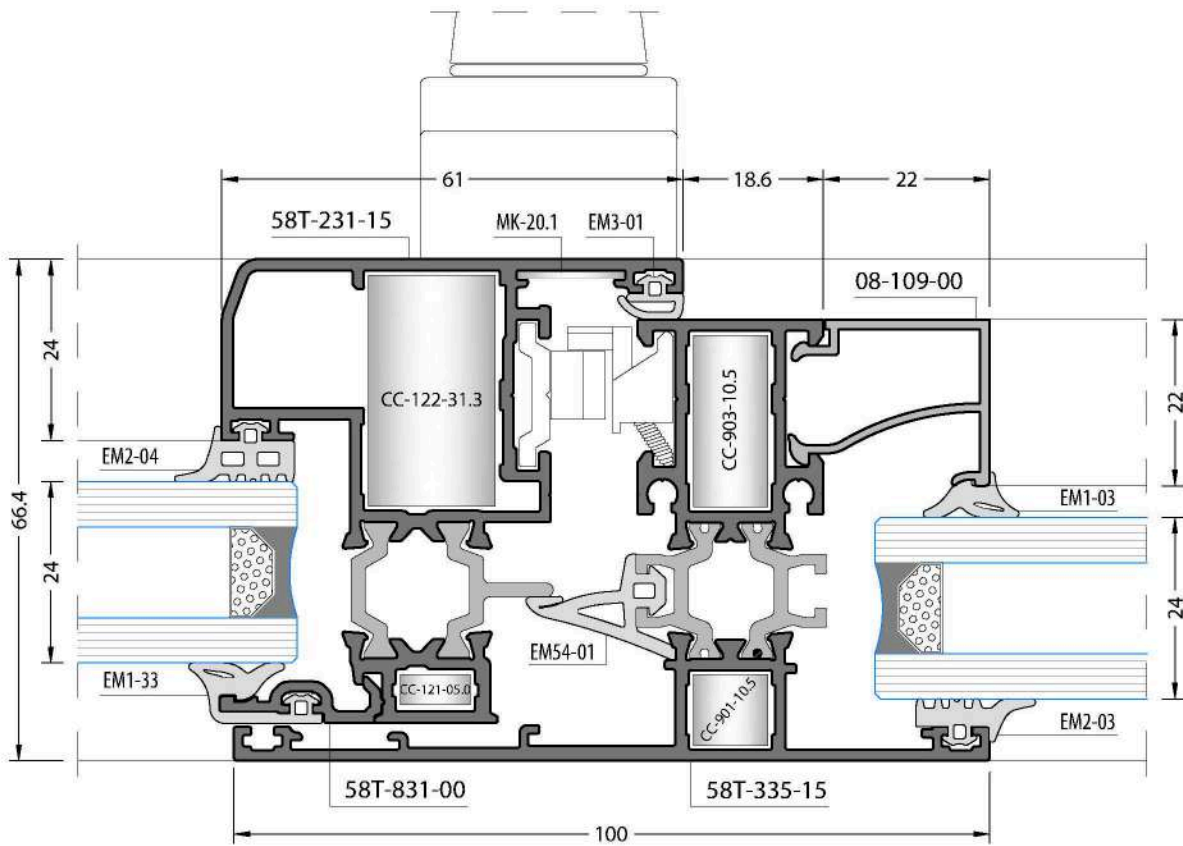
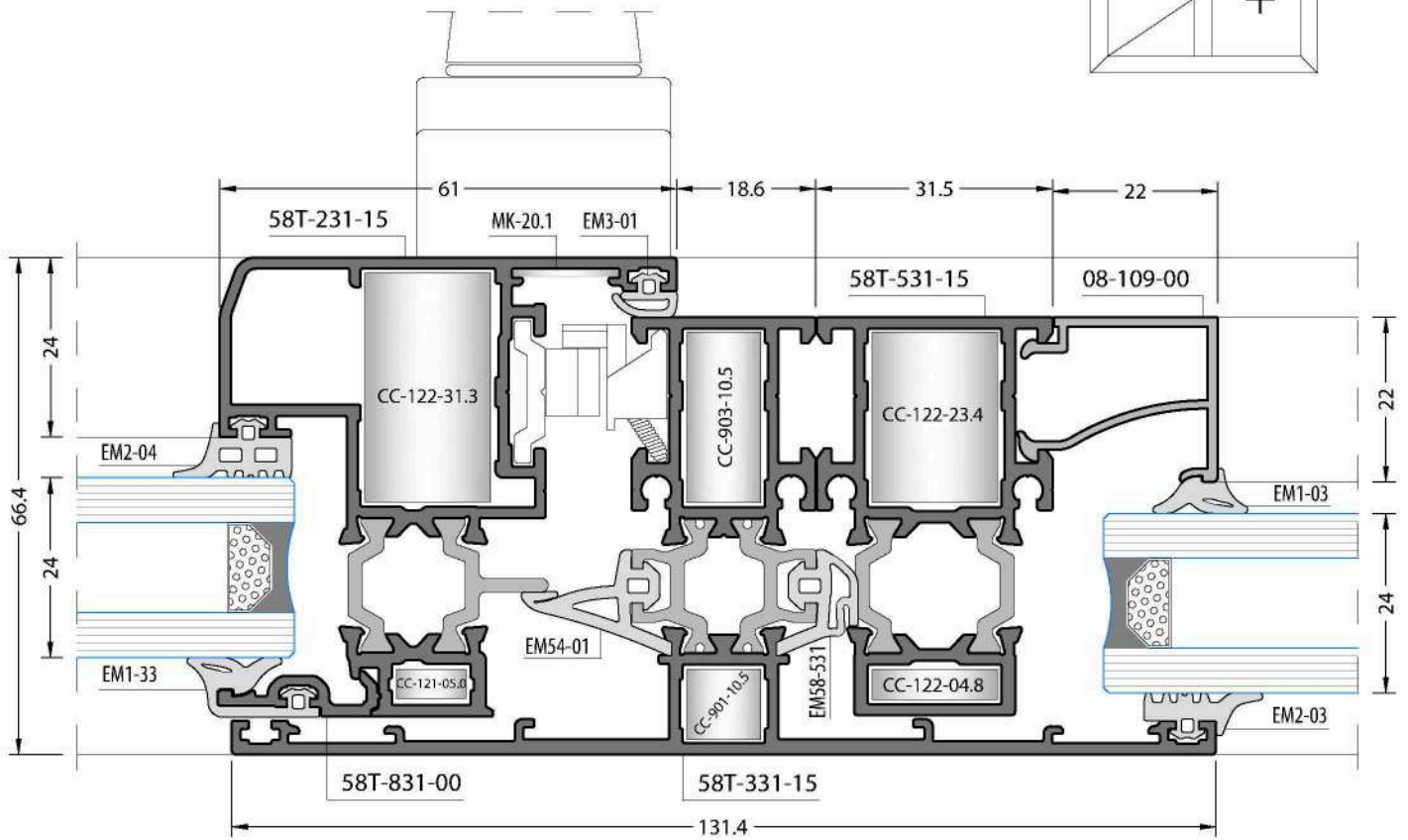
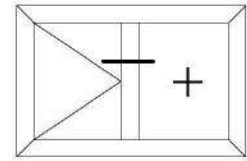

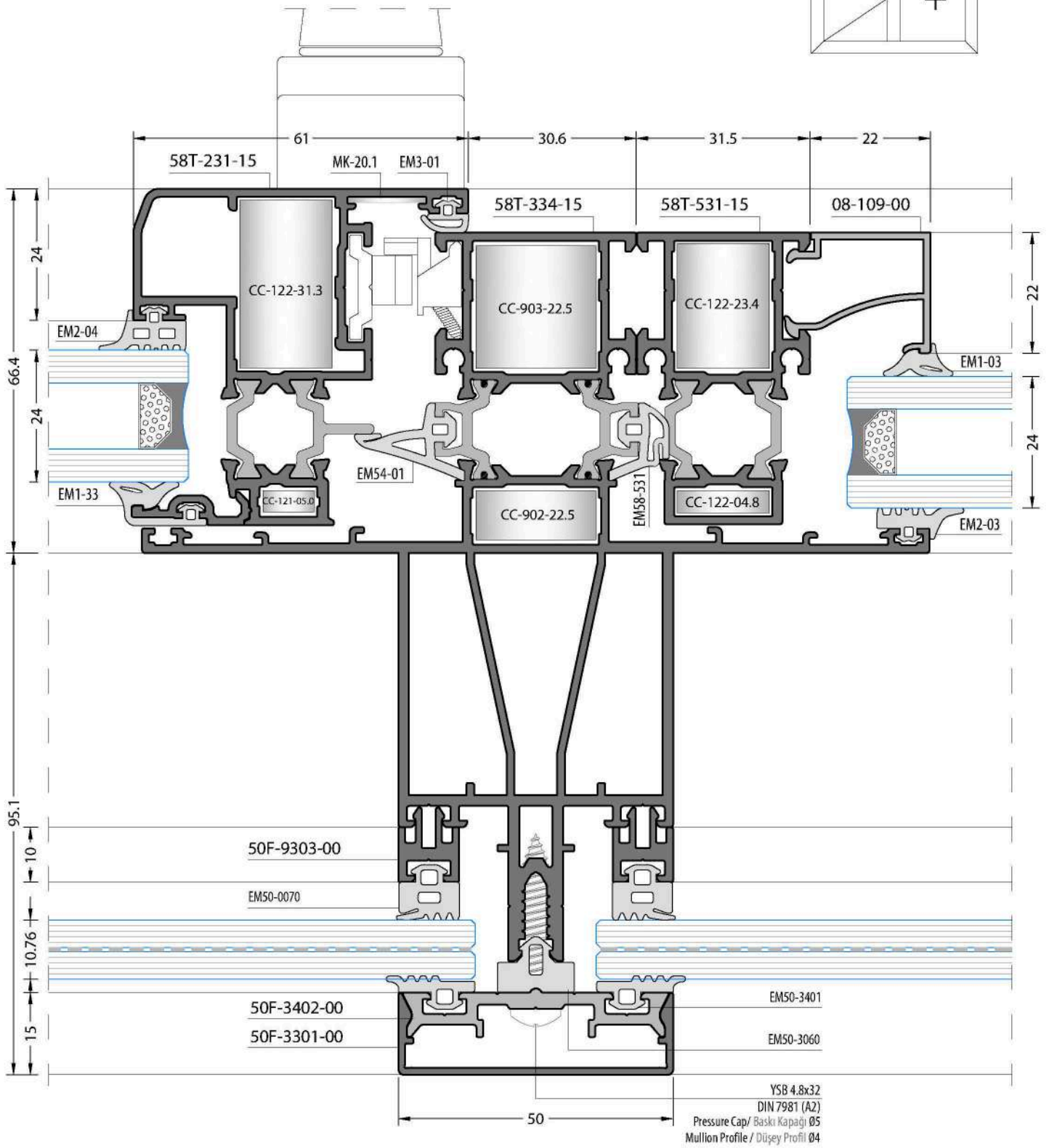
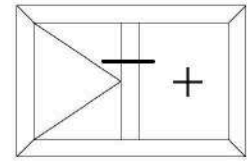

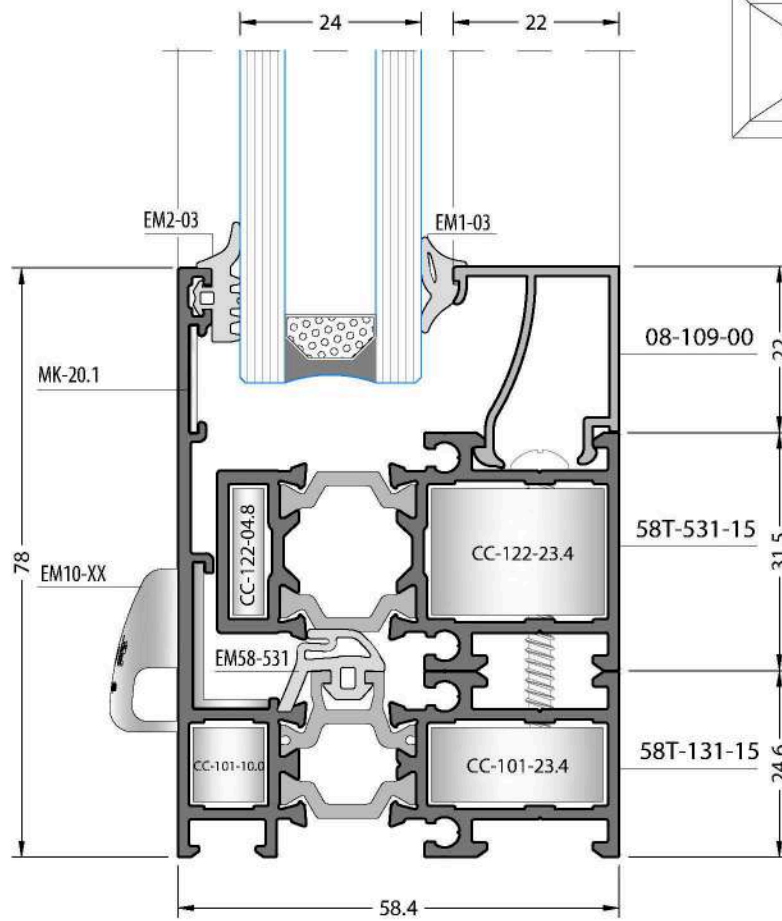
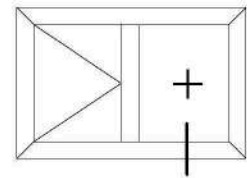
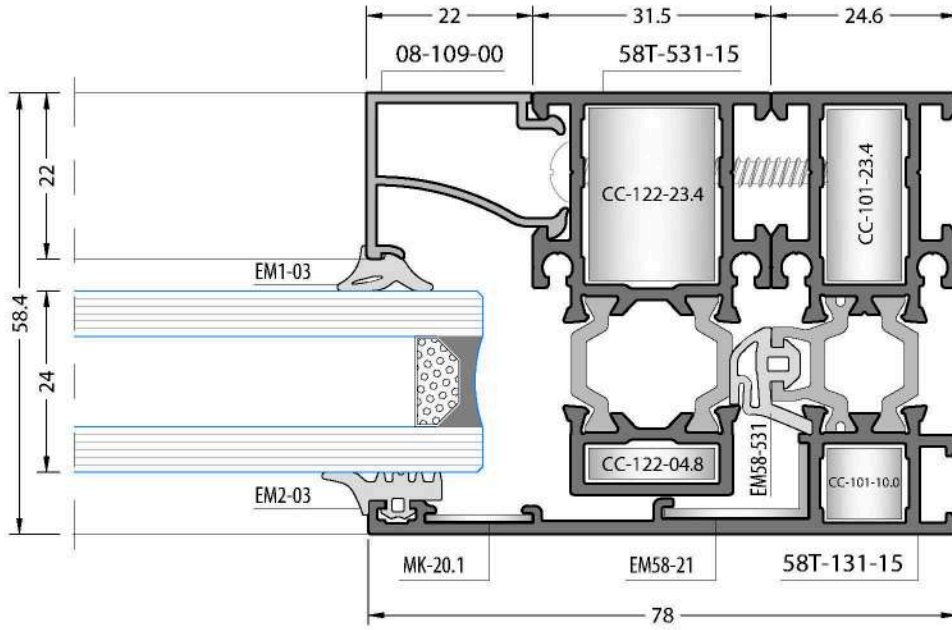
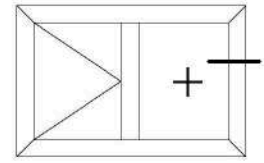

58T

GLAZING TABLES / CAM TABLolari

GLAZING TABLE / CAM TABLOSU

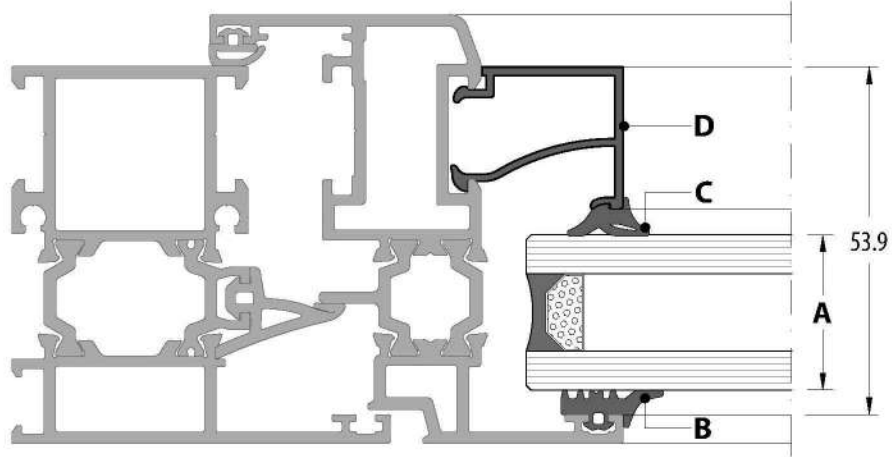

A	B	C	D
GLAZING THICKNESS CAM KALINLIĞI	OUTSIDE GLASS GASKET DIŞ CAM FİTİLİ	INSIDE GLASS GASKET İÇ CAM FİTİLİ	GLAZING BEAD CAM ÇITASI
4 mm	EM2-03	EM1-03	08-121-00
5 mm	EM2-03	EM1-02	
4 mm	EM2-03	EM1-04	08-120-00
5 mm	EM2-03	EM1-03	
6 mm	EM2-03	EM1-02	
7 mm	EM2-03	EM1-05	08-116-00
8 mm	EM2-03	EM1-04	
9 mm	EM2-03	EM1-03	
10 mm	EM2-03	EM1-02	
11 mm	EM2-03	EM1-05	08-115-00
12 mm	EM2-03	EM1-04	
13 mm	EM2-03	EM1-03	
14 mm	EM2-03	EM1-02	
14 mm	EM2-03	EM1-05	08-117-00
15 mm	EM2-03	EM1-04	
16 mm	EM2-03	EM1-03	
17 mm	EM2-03	EM1-02	
15 mm	EM2-03	EM1-05	08-114-00
16 mm	EM2-03	EM1-04	
17 mm	EM2-03	EM1-03	
18 mm	EM2-03	EM1-02	

A	B	C	D
GLAZING THICKNESS CAM KALINLIĞI	OUTSIDE GLASS GASKET DIŞ CAM FİTİLİ	INSIDE GLASS GASKET İÇ CAM FİTİLİ	GLAZING BEAD CAM ÇITASI
16 mm	EM2-03	EM1-05	08-113-00
17 mm	EM2-03	EM1-04	
18 mm	EM2-03	EM1-03	
19 mm	EM2-03	EM1-02	
19 mm	EM2-03	EM1-05	08-112-00
20 mm	EM2-03	EM1-04	
21 mm	EM2-03	EM1-03	
22 mm	EM2-03	EM1-02	
22 mm	EM2-03	EM1-05	08-111-00
23 mm	EM2-03	EM1-04	
24 mm	EM2-03	EM1-03	
25 mm	EM2-03	EM1-02	
22 mm	EM2-03	EM1-05	08-110-00
23 mm	EM2-03	EM1-04	
24 mm	EM2-03	EM1-03	
25 mm	EM2-03	EM1-02	
22 mm	EM2-03	EM1-05	08-109-00
23 mm	EM2-03	EM1-04	
24 mm	EM2-03	EM1-03	
25 mm	EM2-03	EM1-02	

GLAZING TABLE / CAM TABLOSU

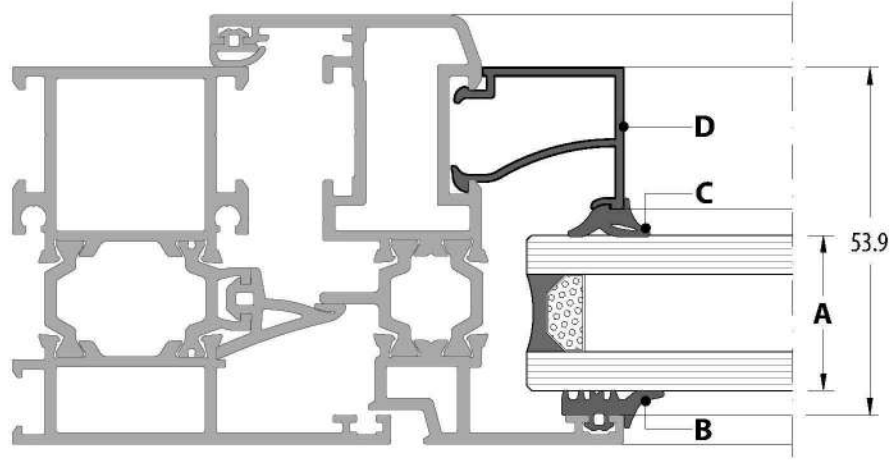

A	B	C	D
GLAZING THICKNESS CAM KALINLIĞI	OUTSIDE GLASS GASKET DIŞ CAM FİTİLİ	INSIDE GLASS GASKET İÇ CAM FİTİLİ	GLAZING BEAD CAM ÇİTASI
25 mm	EM2-03	EM1-05	08-108-00
26 mm	EM2-03	EM1-04	
27 mm	EM2-03	EM1-03	
28 mm	EM2-03	EM1-02	
27 mm	EM2-03	EM1-05	08-107-00
28 mm	EM2-03	EM1-04	
29 mm	EM2-03	EM1-03	
30 mm	EM2-03	EM1-02	
30 mm	EM2-03	EM1-05	08-105-00
31 mm	EM2-03	EM1-04	
32 mm	EM2-03	EM1-03	
33 mm	EM2-03	EM1-02	
31 mm	EM2-03	EM1-05	08-104-00
32 mm	EM2-03	EM1-04	
33 mm	EM2-03	EM1-03	
34 mm	EM2-03	EM1-02	
34 mm	EM2-03	EM1-05	08-103-00
35 mm	EM2-03	EM1-04	
36 mm	EM2-03	EM1-03	
37 mm	EM2-03	EM1-02	

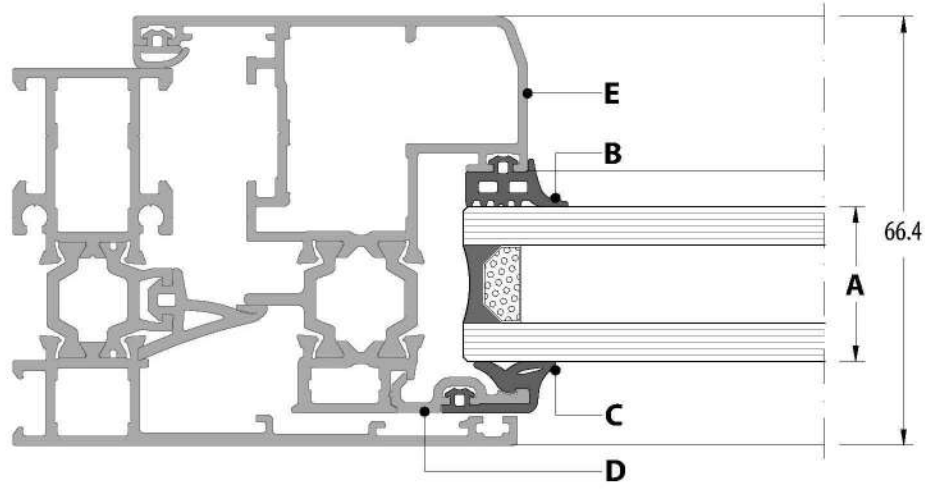









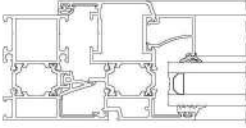

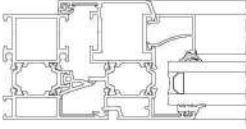

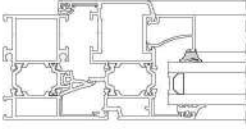
A	B	C	D	E
GLAZING THICKNESS CAM KALINLIĞI	OUTSIDE GLASS GASKET DIŞ CAM FITİLİ	INSIDE GLASS GASKET İÇ CAM FITİLİ	GLAZING BEAD CAM ÇITASI	SASH PROFILE KANAT PROFİLİ
24 mm	EM2-04	EM1-33	58T-831-00	58T-231-15
26 mm	EM2-03			

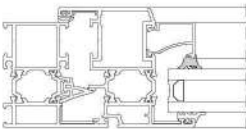

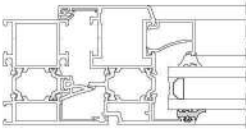

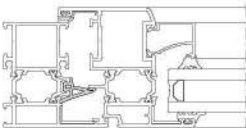

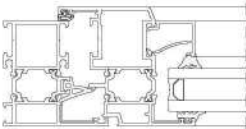

58T

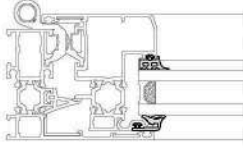
ACCESSORIES / AKSESUARLAR

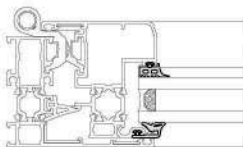
GASKETS / FITİLLER

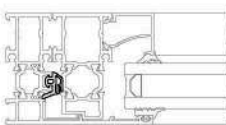
CODE / KOD	DRAWING / ÇİZİM	APPLICATION UYGULAMA	DESCRIPTION AÇIKLAMA	MATERIAL MALZEME	WEIGHT AĞIRLIK Kg/m	IN ONE PACKAGE PAKET MIKTARI
EM1-02			Glazing Gasket Inside İç Cam Fitili	EPDM	0.040	375 m
EM1-03			Glazing Gasket Inside İç Cam Fitili	EPDM	0.050	300 m
EM1-04			Glazing Gasket Inside İç Cam Fitili	EPDM	0.065	230 m
EM1-05			Glazing Gasket Inside İç Cam Fitili	EPDM	0.071	210 m
EM2-03			Glazing Gasket Outside Dış Cam Fitili	EPDM	0.069	215 m
EM54-01			Central Gasket Tozluk Fitili	EPDM	0.128	117 m
EM3-01			Acoustical Gasket Bini Fitili	EPDM	0.032	465 m

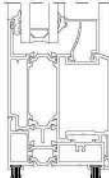
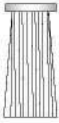
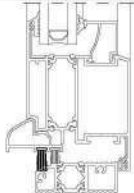
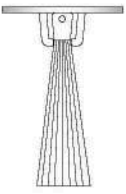





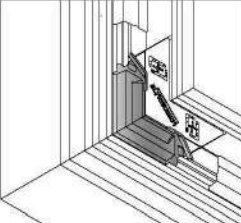



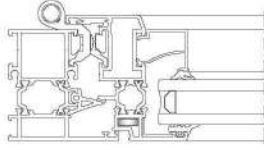

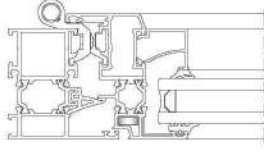

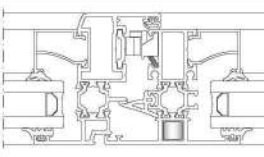

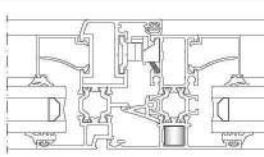

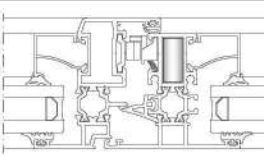
GASKETS / FITİLLER

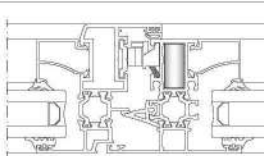
CODE / KOD	DRAWING / ÇİZİM	APPLICATION UYGULAMA	DESCRIPTION AÇIKLAMA	MATERIAL MALZEME	WEIGHT AĞIRLIK Kg/m	IN ONE PACKAGE PAKET MİKTARI
EM2-04			Hidden Sash Glazing Gasket Inside Gizli Kanat İç Cam Fitili	EPDM	0.081	185 m
EM1-33			Hidden Sash Glazing Gasket Outside Gizli Kanat Dış Cam Fitili	EPDM	0.085	175 m
EM58-531			Hidden Sash Central Gasket Gizli Kanat Tozluğ Fitili	EPDM	0.083	180 m
PB-7-1000			Brush / Fırça (10 mm)	-	-	200 m
PB-7-1500			Brush / Fırça (15 mm)	-	-	200 m
AKF-195 B			Brush / Fırça (35 mm)	-	-	90cm / 100 cm

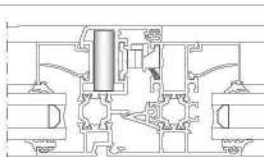

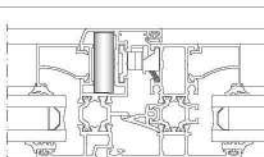

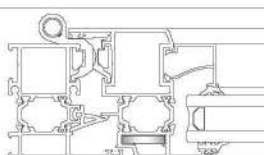

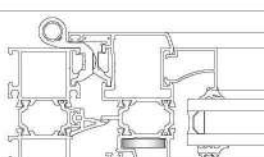



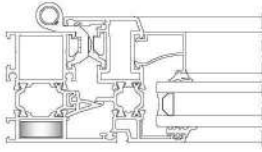

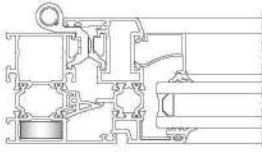

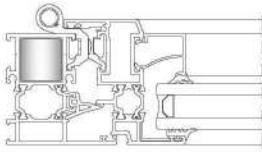

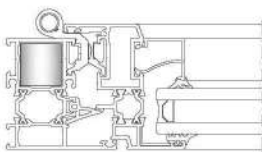
ENJECTION CORNER / ENJEKSİYON KÖŞE

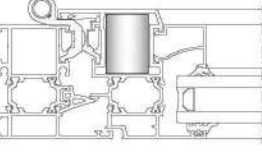
CODE / KOD	DRAWING / ÇİZİM	APPLICATION UYGULAMA	DESCRIPTION AÇIKLAMA	MATERIAL MALZEME	WEIGHT AĞIRLIK Kg/m	IN ONE PACKAGE PAKET MİKTARI
EM54-C01			-	EPDM	-	50 Pieces / Adet

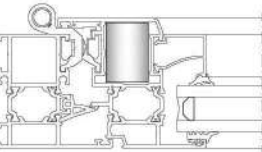

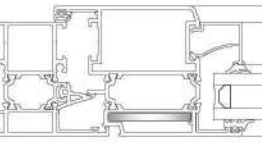

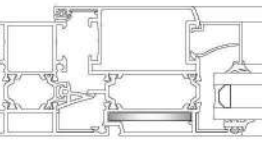

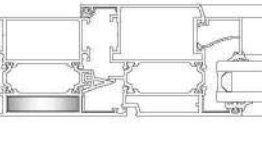



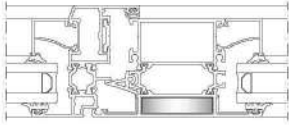

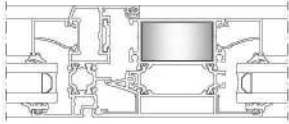

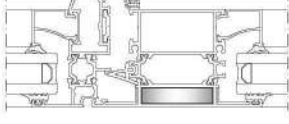

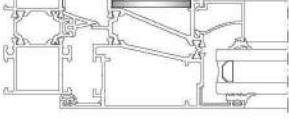

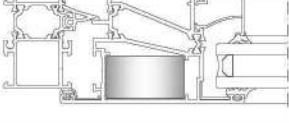
CUTTED CORNER JOINTS / KESİLMİŞ KÖŞE TAKOZLAR

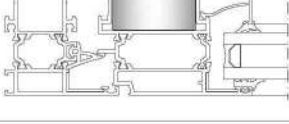
CODE / KOD	DRAWING / ÇİZİM	APPLICATION / UYGULAMA	PROFILE CODE PROFİL KOD	CUTTING SIZE KESİM ÖLÇÜSÜ	APPLICATION PROFILES ÇALIŞTIĞI PROFİLLER
CC-101-04.6			09-101-00	4.6 mm	58T-201-18 58T-201-20
CC-101-04.9			09-101-00	4.9 mm	58T-201-15
CC-101-09.6			09-101-00	9.6 mm	58T-301-18 58T-301-20 58T-507-18
CC-101-10.0			09-101-00	10 mm	58T-301-15 58T-131-15 58T-141-15 58T-335-15
CC-101-23.0			09-101-00	23 mm	58T-301-18 58T-301-20 58T-507-18
CC-101-23.4			09-101-00	23.4 mm	58T-301-15 58T-131-15 58T-141-15 58T-335-15
CC-101-30.8			09-101-00	30.8 mm	58T-201-18 58T-201-20
CC-101-31.3			09-101-00	31.3 mm	58T-201-15
CC-103-04.6			09-103-00	4.6 mm	58T-202-18 58T-202-20 58T-252-18 58T-404-18 58T-503-18
CC-103-04.9			09-103-00	4.9 mm	58T-202-15 58T-252-15

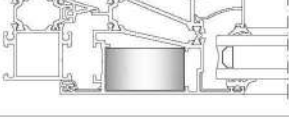

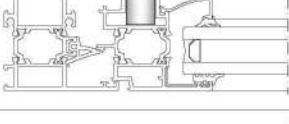

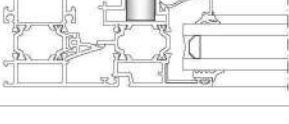

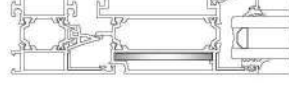



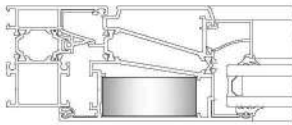

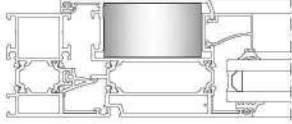

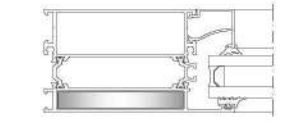

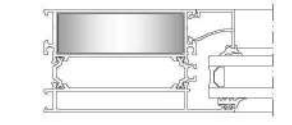
CUTTED CORNER JOINTS / KESİLMİŞ KÖŞE TAKOZLAR

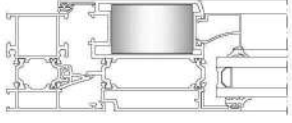
CODE / KOD	DRAWING / ÇİZİM	APPLICATION / UYGULAMA	PROFILE CODE PROFİL KOD	CUTTING SIZE KESİM ÖLÇÜSÜ	APPLICATION PROFILES ÇALIŞTIĞI PROFİLLER
CC-103-09.6			09-103-00	9.6 mm	58T-102-18 58T-122-18 58T-302-18 58T-302-20 58T-312-18 58T-322-18
CC-103-10.0			09-103-00	9.6 mm	58T-102-15 58T-112-15 58T-302-15 58T-312-15
CC-103-23.0			09-103-00	23.0 mm	58T-102-18 58T-122-18 58T-302-18 58T-312-18 58T-322-18 58T-404-18 58T-302-20
CC-103-23.4			09-103-00	23.4 mm	58T-102-15 58T-112-15 58T-302-15 58T-312-15
CC-103-30.8			09-103-00	30.8 mm	58T-202-18 58T-202-20
CC-103-31.3			09-103-00	31.3 mm	58T-202-15
CC-105-04.6			09-105-00	4.6 mm	58T-204-18 58T-205-18 58T-204-20 58T-205-20
CC-105-04.9			09-105-00	4.9 mm	58T-204-15 58T-205-15
CC-105-09.6			09-105-00	9.6 mm	58T-104-18 58T-304-18

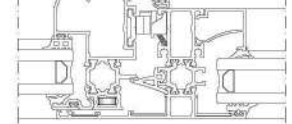

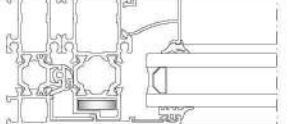

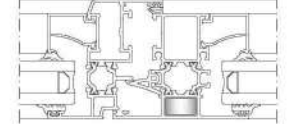

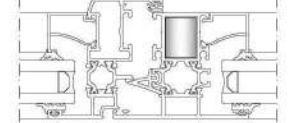
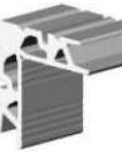
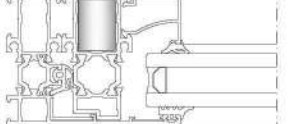



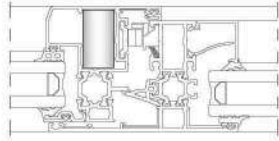

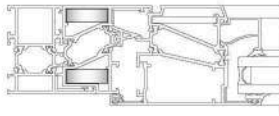

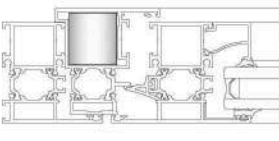
CUTTED CORNER JOINTS / KESİLMİŞ KÖŞE TAKOZLAR

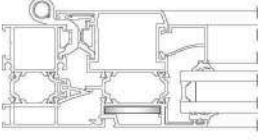
CODE / KOD	DRAWING / ÇİZİM	APPLICATION / UYGULAMA	PROFILE CODE PROFİL KOD	CUTTING SIZE KESİM ÖLÇÜSÜ	APPLICATION PROFILES ÇALIŞTIĞI PROFİLLER
CC-105-10.0			09-105-00	10 mm	58T-304-15
CC-105-23.0			09-105-00	23 mm	58T-104-18 58T-304-18
CC-105-23.4			09-105-00	23.4 mm	58T-304-15
CC-105-23.6			09-105-00	23.6 mm	58T-205-18 58T-205-20
CC-105-23.8			09-105-00	23.8 mm	58T-205-15
CC-105-30.8			09-105-00	30.8 mm	58T-204-18 58T-204-20
CC-105-31.3			09-105-00	31.3 mm	58T-204-15
CC-110-31.0			09-110-00	31.0 mm	58T-252-18
CC-110-31.3			09-110-00	31.3 mm	58T-252-15
CC-113-04.5			09-113-00	4.5 mm	58T-206-18 58T-207-18 58T-256-18

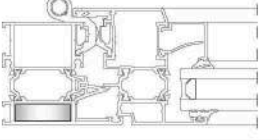

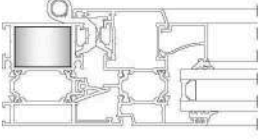

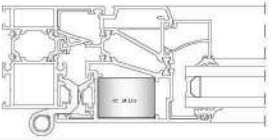

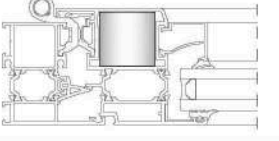
CUTTED CORNER JOINTS / KESİLMİŞ KÖŞE TAKOZLAR

CODE / KOD	DRAWING / ÇİZİM	APPLICATION / UYGULAMA	PROFILE CODE PROFİL KOD	CUTTING SIZE KESİM ÖLÇÜSÜ	APPLICATION PROFILES ÇALIŞTIĞI PROFİLLER
CC-113-23.5			09-113-00	23.5 mm	58T-207-18
CC-113-31.0			09-113-00	31 mm	58T-206-18
CC-114-09.6			09-114-00	9.6 mm	58T-105-18 58T-305-18
CC-114-23.0			09-114-00	23 mm	58T-105-18 58T-305-18
CC-117-30.2			09-117-00	30.2 mm	58T-256-18
CC-121-05.0			09-121-00	5 mm	58T-231-15
CC-122-04.8			09-122-00	4.8 mm	58T-531-15
CC-122-09.6			09-122-00	9.6 mm	58T-306-18
CC-122-23.0			09-122-00	23 mm	58T-306-18
CC-122-23.4			09-122-00	23.4 mm	58T-531-15

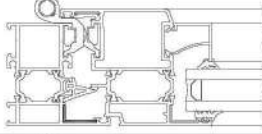

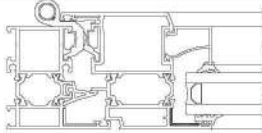

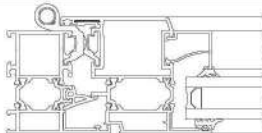

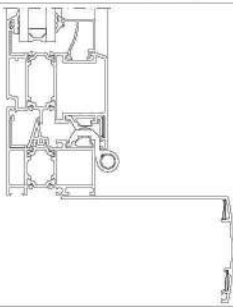



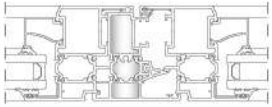

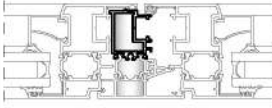

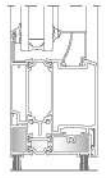
CUTTED CORNER JOINTS / KESİLMİŞ KÖŞE TAKOZLAR

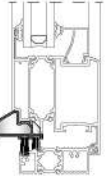
CODE / KOD	DRAWING / ÇİZİM	APPLICATION / UYGULAMA	PROFILE CODE PROFİL KOD	CUTTING SIZE KESİM ÖLÇÜSÜ	APPLICATION PROFILES ÇALIŞTIĞI PROFİLLER
CC-122-31.3			09-122-00	31.3 mm	58T-231-15
CC-123-09.5			09-123-00	9.5 mm	58T-502-18
CC-123-31.0			09-123-00	31 mm	58T-503-18
CC-124-04.6			09-124-00	4.6 mm	58T-203-18 58T-215-18
CC-124-09.6			09-124-00	9.6 mm	58T-103-18 58T-113-18 58T-303-18
CC-124-23.0			09-124-00	23 mm	58T-103-18 58T-113-18 58T-303-18
CC-124-23.5			09-124-00	23.5 mm	58T-215-18
CC-124-30.8			09-124-00	30.8 mm	58T-203-18

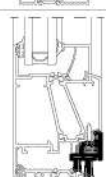
CORNER ACCESSORIES / KÖŞE BAĞLANTILAR

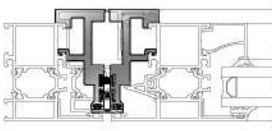
PACKAGE CODE PAKET KODU	DRAWING / ÇİZİM	APPLICATION / UYGULAMA	DESCRIPTION AÇIKLAMA	MATERIAL MALZEME	APPLICATION PROFILES ÇALIŞTIĞI PROFİLLER
EM58-21			Corner Joint Köşe Bağlantı	PVC	All Frames & Mullions Tüm Kasa ve Orta Kayıtlar
EM58-22			Corner Joint Köşe Bağlantı	PVC	All Vents Tüm Kanatlar
MK-20.1			Corner Joint Köşe Bağlantı	METAL	All Vents Tüm Kanatlar
LC-122			Corner Joint Köşe Bağlantı	DIE-CAST DÖKÜM	07-105-00

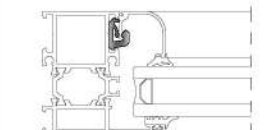
OTHER ACCESSORIES / DİĞER AKSESUARLAR

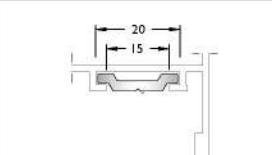
PACKAGE CODE PAKET KODU	DRAWING / ÇİZİM	APPLICATION UYGULAMA	APPLICATION PROFILES ÇALIŞTIĞI PROFİLLER	DESCRIPTION AÇIKLAMA	MATERIAL MALZEME
EM58T-501			58T-501-18 58T-545-18	Adapter Cap Adaptör Kapağı	PVC
EM58T-551			58T-551-18	Adapter Cap Adaptör Kapağı	PVC
EM58T-403			58T-403-18	Adapter Cap Adaptör Kapağı	PVC
EM58T-405			58T-405-00	Inside Sash İçe Açılır Kanat Dropper Cap Damlalık Kapağı	PVC
EM70T-406			70T-406-00	Outside Sash Dışa Açılır Kanat Dropper Cap Damlalık Kapağı	PVC
EM58-520			58T-503-18	Pivot Adapter Pivot Adaptör	Aluminium Alüminyum
EM08-111			08-111-00	Glazing Bead Adapter Çita Adaptörü	PVC
EM15-200			-	Polyamid Rod Profile (Euro Section 1) Polyamid Tij Profili (Avrupa Kanal 1)	Polyamid

OTHER ACCESSORIES / DİĞER AKSESUARLAR

PACKAGE CODE PAKET KODU	CODE / KOD	DESCRIPTION AÇIKLAMA	APPLICATION GASKET ÇALIŞTIĞI FITİL	MATERIAL MALZEME
GTOOL-EM54-01		GASKET TOOL FITİL APARATI	EM54-01	PVC

MONTAGE TO FRAME T JUNCTION / KASAYA ÇEKTİRME BAęLANTI

APPLICATION PROFILES ÇALIŞTIĐI PROFİLLER	PACKAGE CODE PAKET KODU	PROFILE CODE PROFİL KOD	CUTTING SIZE KESİM ÖLÇÜSÜ	A SCREW QUANTITY VİDA ADET	APPLICATION PROFILES ÇALIŞTIĐI PROFİLLER	PACKAGE CODE PAKET KODU	PROFILE CODE PROFİL KOD	CUTTING SIZE KESİM ÖLÇÜSÜ	A SCREW QUANTITY VİDA ADET
58T-301-18 58T-301-15 58T-301-20 58T-331-15 58T-335-15	CC-901-10.5 CC-903-10.5	09-901-00 09-903-00	10.5 mm	1	58T-303-18 58T-304-18 58T-304-15	CC-901-32.4 CC-903-32.4	09-901-00 09-903-00	32.4 mm	2
58T-306-18	CC-901-17.4 CC-903-17.4	09-901-00 09-903-00	17.4 mm	2	58T-305-18 58T-105-18	CC-901-71.9 CC-903-71.9	09-901-00 09-903-00	71.9 mm	2
58T-302-18 58T-312-18 58T-322-18 58T-302-15 58T-312-15 58T-302-20 58T-332-15	CC-901-22.5 CC-903-22.5	09-901-00 09-903-00	22.5 mm	2	58T-402-18	CC-901-65.7 CC-903-67.7	09-901-00 09-903-00	65.7 mm 67.7 mm	2

APPLICATION / UYGULAMA

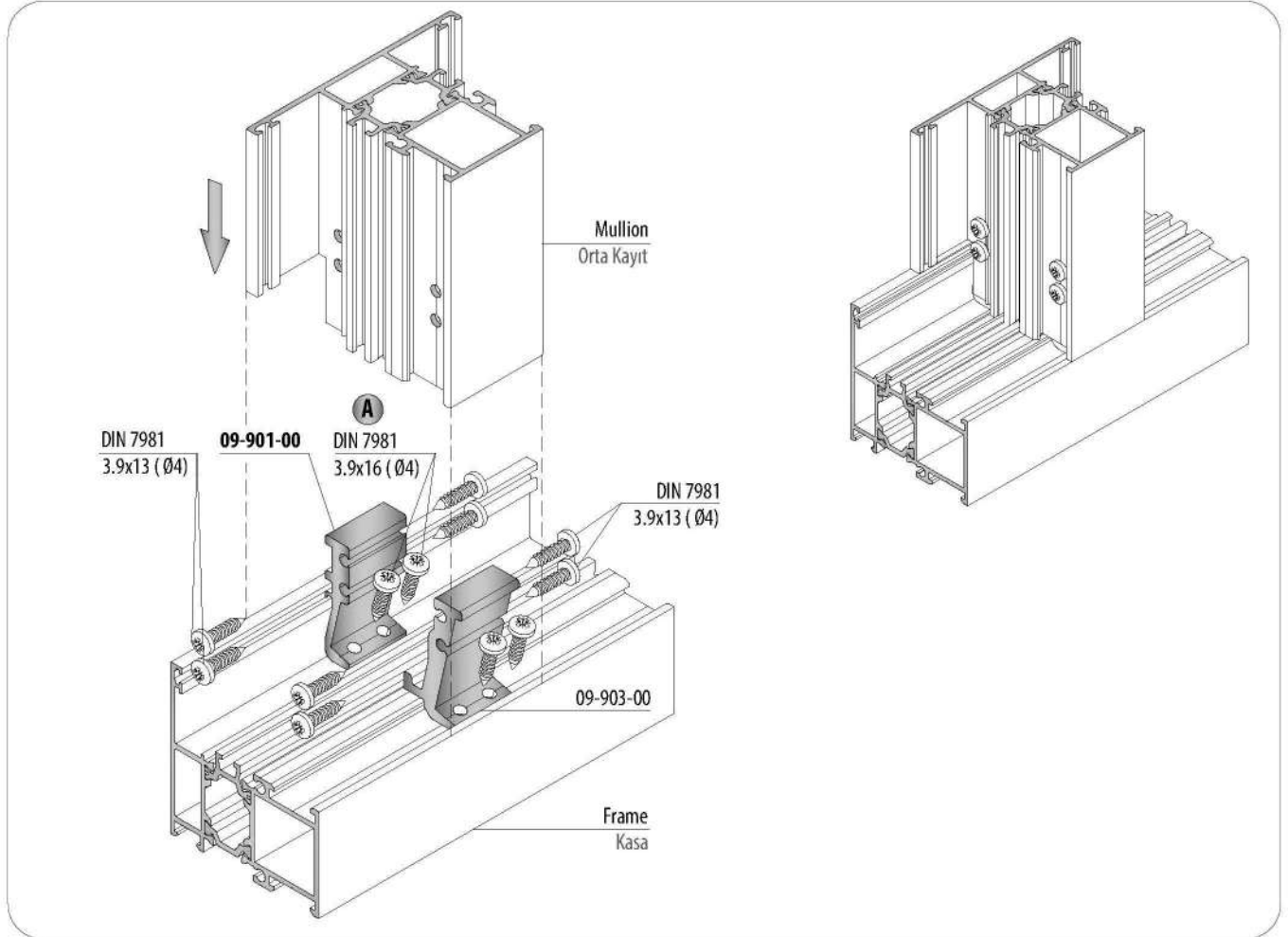

MONTAGE TO SASH T JUNCTION / KANAT ÇEKTİRME BAĞLANTI

APPLICATION PROFILES ÇALIŞTIĞI PROFİLLER	PACKAGE CODE PAKET KODU	PROFILE CODE PROFİL KODU	CUTTING SIZE KESİM ÖLÇÜSÜ	A SCREW QUANTITY VİDA ADET	APPLICATION PROFILES ÇALIŞTIĞI PROFİLLER	PACKAGE CODE PAKET KODU	PROFILE CODE PROFİL KODU	CUTTING SIZE KESİM ÖLÇÜSÜ	A SCREW QUANTITY VİDA ADET
58T-301-18 58T-301-15 58T-301-20 58T-331-15 58T-335-15	CC-902-10.5 CC-903-10.5	09-902-00 09-903-00	10.5 mm	1	58T-303-18 58T-304-18 58T-304-15	CC-902-32.4 CC-903-32.4	09-902-00 09-903-00	32.4 mm	2
58T-306-18	CC-902-17.4 CC-903-17.4	09-902-00 09-903-00	17.4 mm	2	58T-305-18 58T-105-18	CC-902-71.9 CC-903-71.9	09-902-00 09-903-00	71.9 mm	2
58T-302-18 58T-312-18 58T-322-18 58T-302-15 58T-312-15 58T-302-20 58T-332-15	CC-902-22.5 CC-903-22.5	09-902-00 09-903-00	22.5 mm	2	58T-402-18 58T-412-18	CC-902-65.7 CC-903-67.7 CC-902-40.0 CC-903-40.0	09-902-00 09-903-00 09-902-00 09-903-00	65.7 mm 67.7 mm 40.0 mm 40.0 mm	2 2

APPLICATION / UYGULAMA

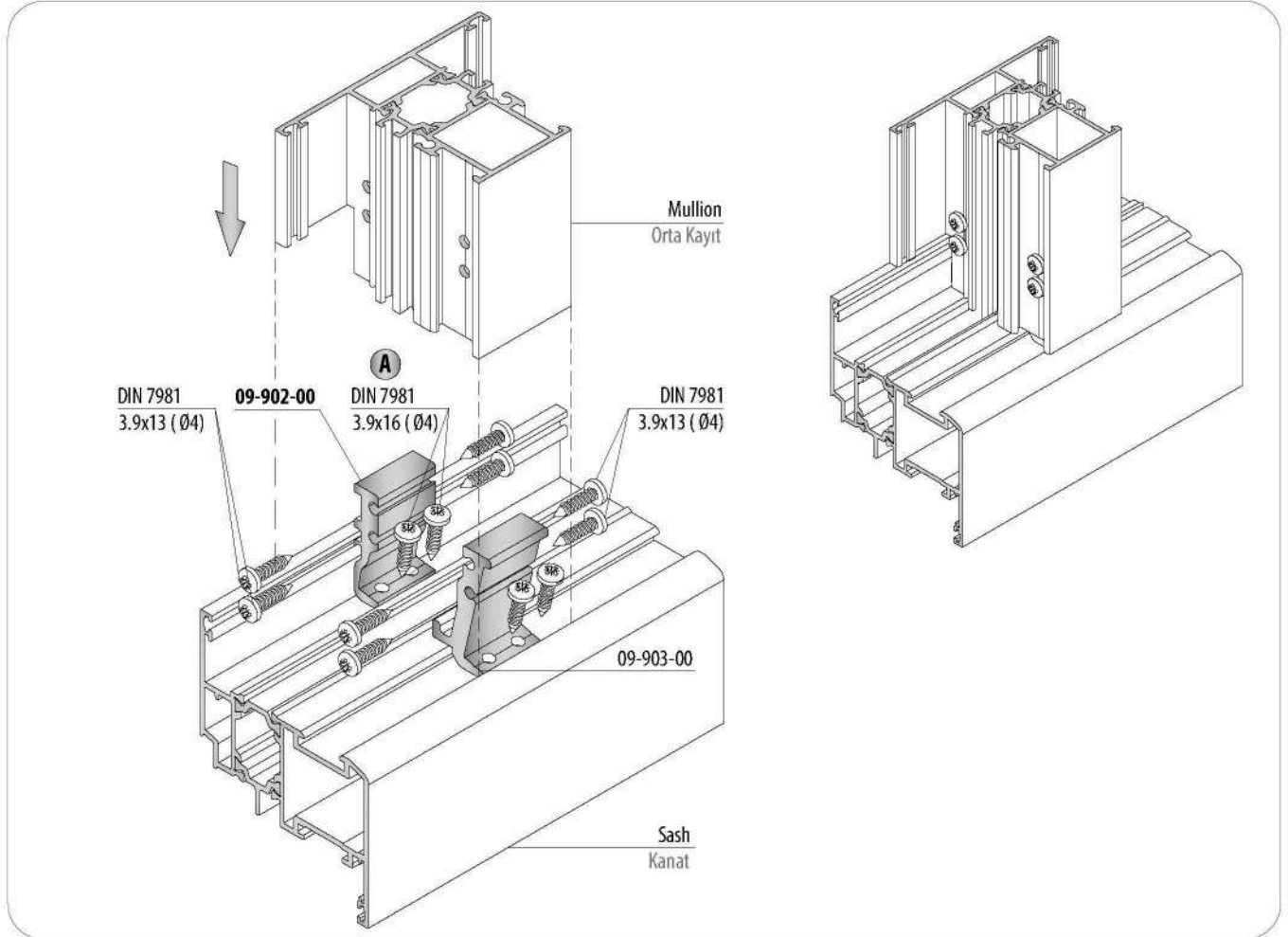

58T

CUTTING SIZE / KESİM ÖLÇÜLERİ

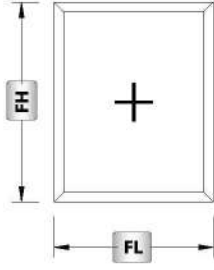
**GLASS / CAM**

Code Kod	Drawing Çizim	Quantity Miktar	Dimensions (mm) Boyutlar
Glass Cam		1 Pcs / Adet	$GL = FL - (A1+A1) - 14$ $GH = FH - (A1+A1) - 14$

PROFILES / PROFİLLER

Code Kod	Drawing Çizim	Cut Kesim	Quantity Miktar	Dimensions (mm) Boyutlar
58T-102-18			2 Pcs / Adet	FL
			2 Pcs / Adet	FH
08-109-00			2 Pcs / Adet	$CL = FL - (A1+A1)$
			2 Pcs / Adet	$CH = FH - (A1+A1+22+22)$

CONNECTIONS / BAĞLANTILAR

Code Kod	Quantity Miktar	Picture Resim
CC-103-23.0	4 Pcs / Adet	
CC-103-09.6	4 Pcs / Adet	
EM58-21	4 Pcs / Adet	

GASKETS / FİTİLLER

Code Kod	Quantity Miktar	Picture Resim
EM1-XX	2SL + 2SH	
EM2-03	2SL + 2SH	

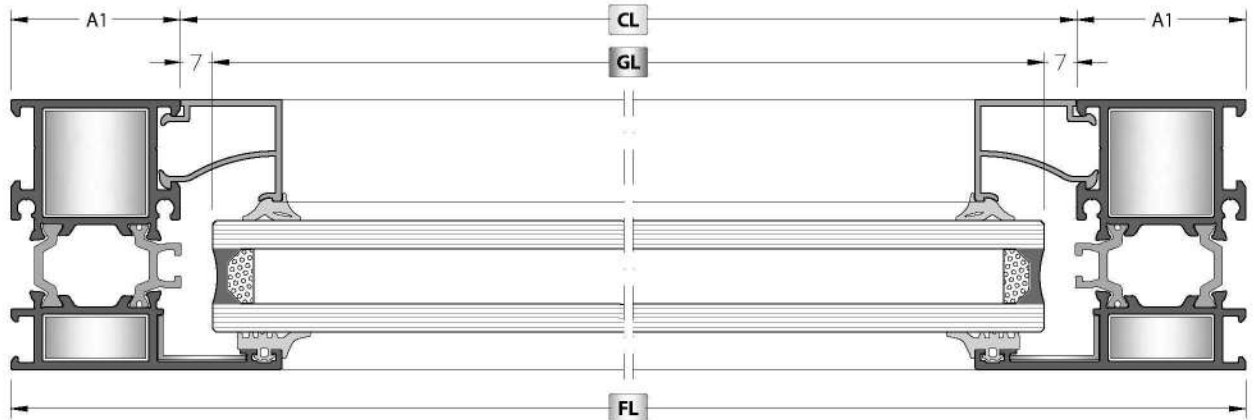
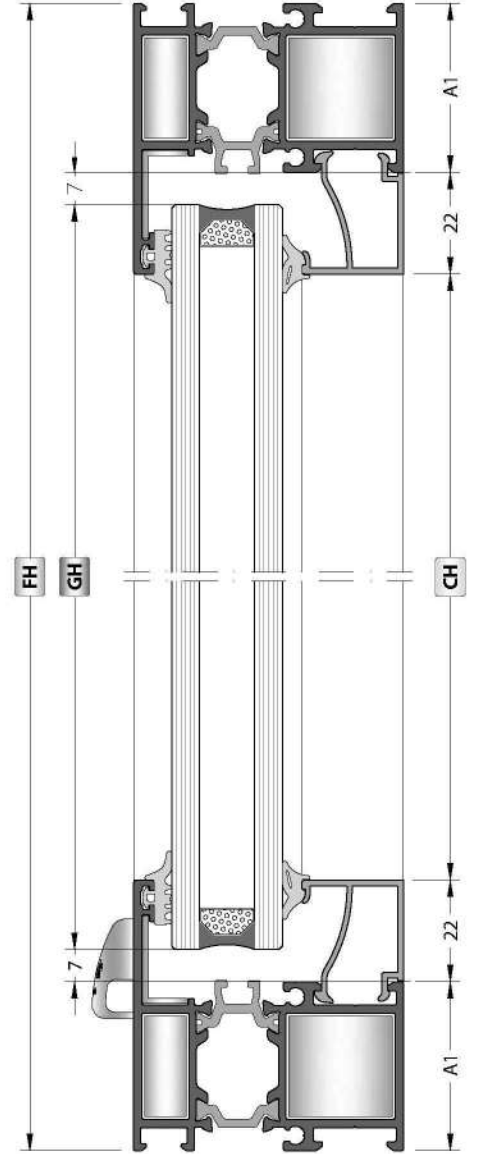

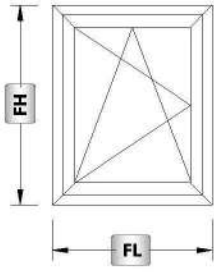

GLASS / CAM

Code Kod	Drawing Çizim	Quantity Miktar	Dimensions (mm) Boyutlar
Glass Cam		1 Pcs / Adet	$GL = SL - (A2+A2) - 14$ $GH = SH - (A2+A2) - 14$

PROFILES / PROFİLLER

Code Kod	Drawing Çizim	Cut Kesim	Quantity Miktar	Dimensions (mm) Boyutlar
58T-102-18			2 Pcs / Adet	FL
			2 Pcs / Adet	FH
58T-201-18			2 Pcs / Adet	$SL = FL - (A1+A1) + 12$
			2 Pcs / Adet	$SH = FH - (A1+A1) + 12$
08-109-00			2 Pcs / Adet	$CL = SL - (A2+A2)$
			2 Pcs / Adet	$CH = SH - (A2+A2+22+22)$

CONNECTIONS / BAĞLANTILAR

Code Kod	Quantity Miktar	Picture Resim
CC-103-23.0	4 Pcs / Adet	
CC-103-09.6	4 Pcs / Adet	
CC-101-30.8	4 Pcs / Adet	
CC-101-04.6	4 Pcs / Adet	
EM58-21	4 Pcs / Adet	
EM58-22	4 Pcs / Adet	
MK-20.1	4 Pcs / Adet	
EM54-C01	4 Pcs / Adet	

GASKETS / FİTİLLER

Code Kod	Quantity Miktar	Picture Resim
EM1-XX	2SL + 2SH	
EM2-03	2SL + 2SH	
EM54-01	2SL + 2SH	
EM3-01	2SL + 2SH	

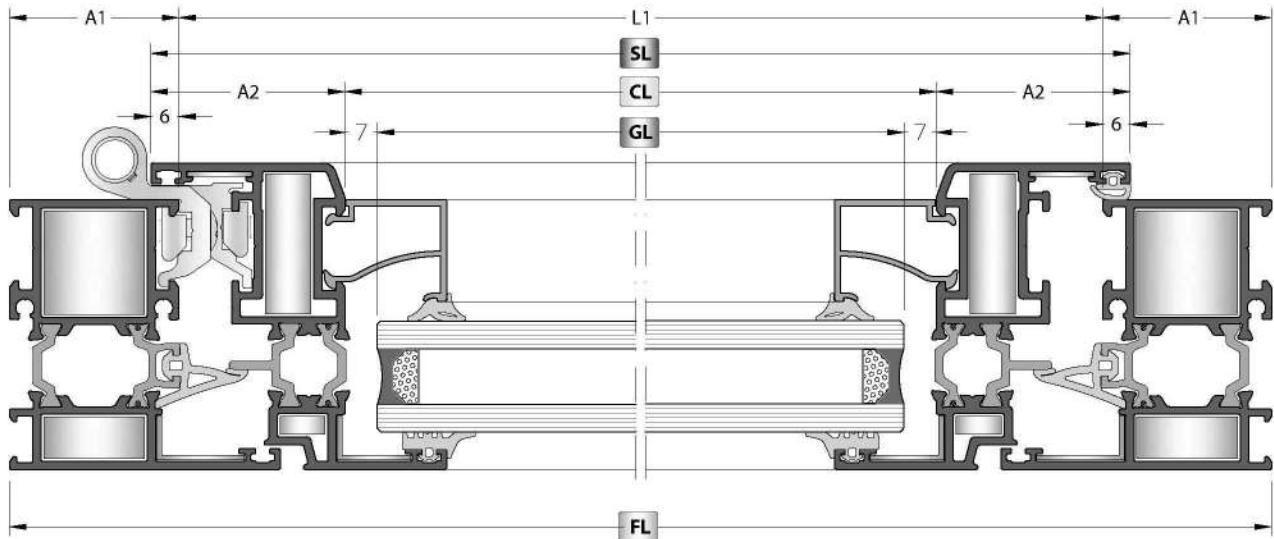
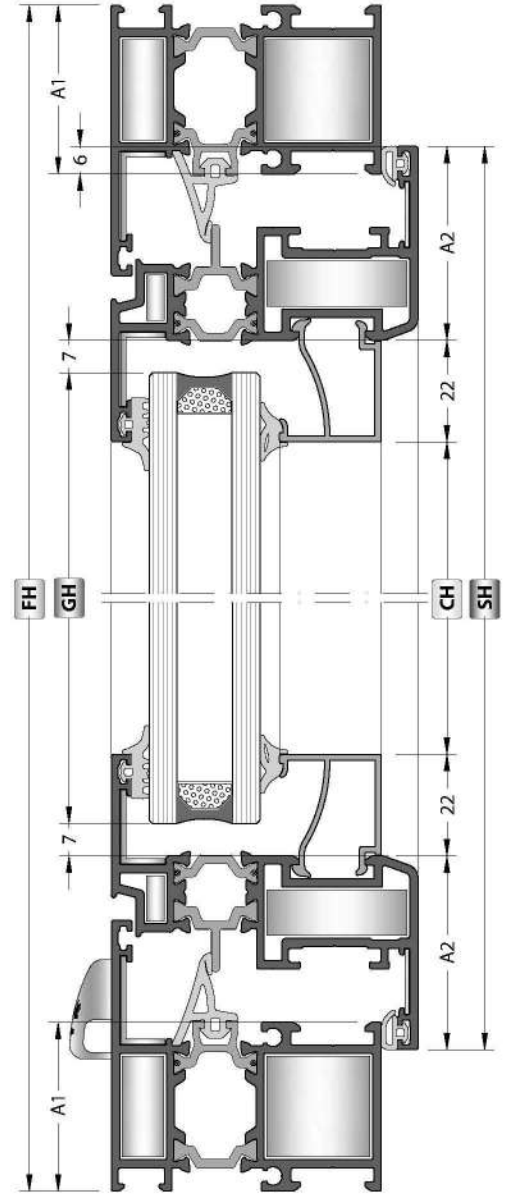

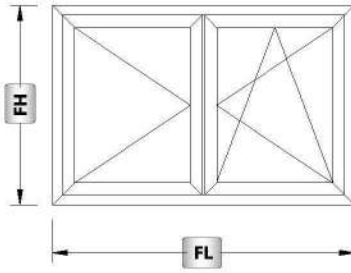

GLASS / CAM

Code Kod	Drawing Çizim	Quantity Miktar	Dimensions (mm) Boyutlar
Glass Cam		2 Pcs / Adet	GL = SL - (A2+A2) - 14 GH = SH - (A2+A2) - 14

PROFILES / PROFİLLER

Code Kod	Drawing Çizim	Cut Kesim	Quantity Miktar	Dimensions (mm) Boyutlar
58T-102-18			2 Pcs / Adet	FL
			2 Pcs / Adet	FH
58T-201-18			4 Pcs / Adet	$SL = \frac{FL - (A1 + A1) + 7}{2}$
			4 Pcs / Adet	SH = FH - (A1+A1) + 12
58T-501-18			1 Pcs / Adet	AH = SH - 70
08-109-00			4 Pcs / Adet	CL = SL - (A2+A2)
			4 Pcs / Adet	CH = SH - (A2+A2+22+22)

CONNECTIONS / BAĞLANTILAR

Code Kod	Quantity Miktar	Picture Resim
CC-103-23.0	4 Pcs / Adet	
CC-103-09.6	4 Pcs / Adet	
CC-101-30.8	8 Pcs / Adet	
CC-101-04.6	8 Pcs / Adet	
EM58-21	4 Pcs / Adet	
EM58-22	8 Pcs / Adet	
MK-20.1	8 Pcs / Adet	
EM58T-501	1 Set / Takım	
EM54-C01	4 Pcs / Adet	

GASKETS / FİTİLLER

Code Kod	Quantity Miktar	Picture Resim
EM1-XX	2SL + 4SH	
EM2-03	2SL + 4SH	
EM54-01	2SL + 3SH	
EM3-01	2SL + 3SH	

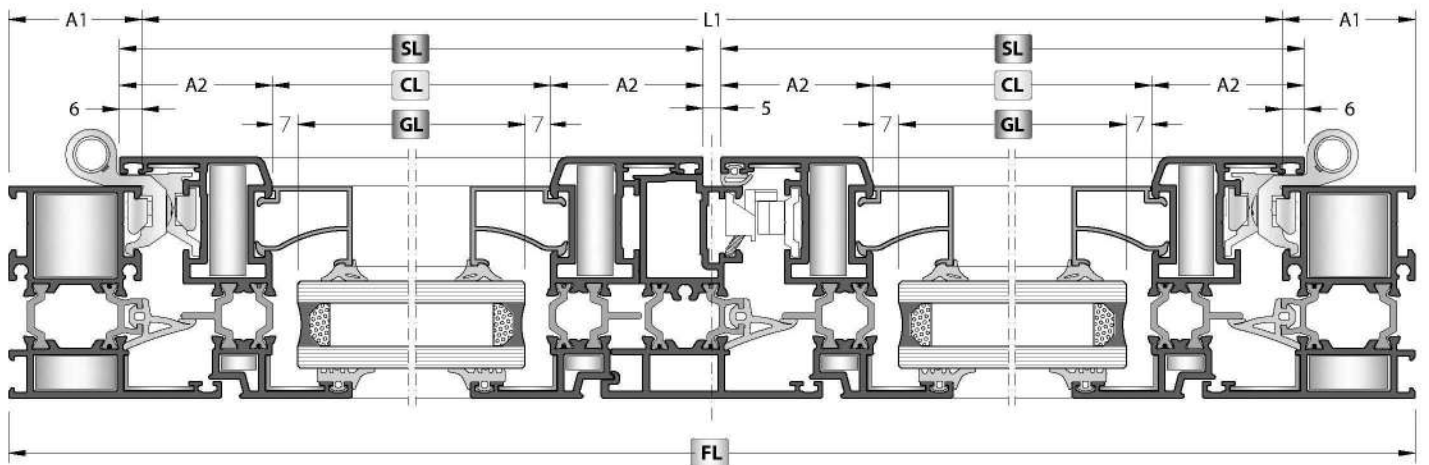
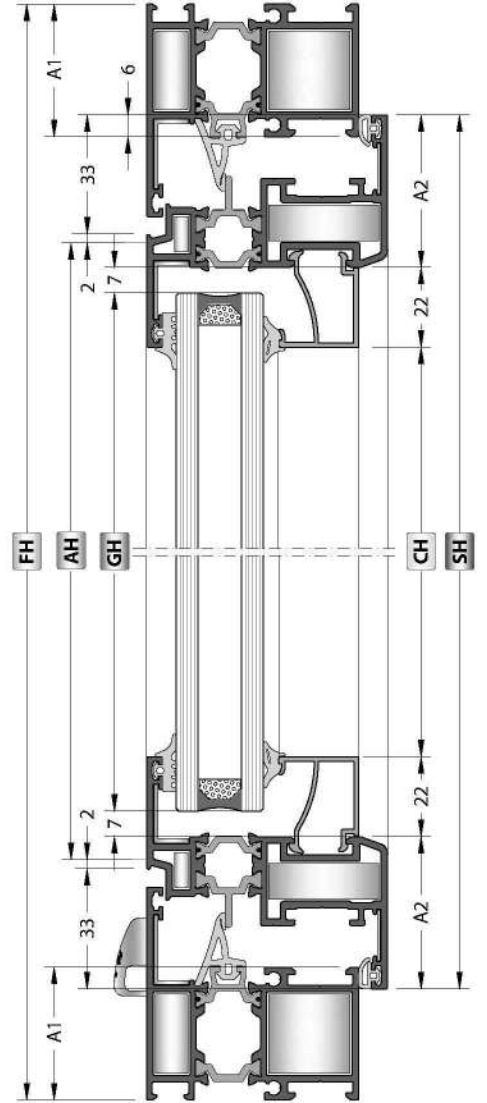

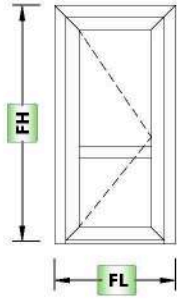

Depend to mullion position
* Orta kayıt pozisyonuna bağlıdır.

GLASS / CAM

Code Kod	Drawing Çizim	Quantity Miktar	Dimensions (mm) Boyutlar
Glass Cam		2 Pcs / Adet	GL = SL - (A2+A2) - 14 *

PROFILES / PROFİLLER

Code Kod	Drawing Çizim	Cut Kesim	Quantity Miktar	Dimensions (mm) Boyutlar
58T-102-18			1 Pcs / Adet	FL
			1 Pcs / Adet	FH
			1 Pcs / Adet	FH
58T-204-18			2 Pcs / Adet	SL = FL - (A1+A1) + 12
			2 Pcs / Adet	SH = FH - (A1+10) + 6
58T-302-18			1 Pcs / Adet	ML = SL - (A2+A2)
08-109-00			4 Pcs / Adet	CL = SL - (A2+A2)
			4 Pcs / Adet	*
58T-403-18			1 Pcs / Adet	AL = SL - 70

CONNECTIONS / BAĞLANTILAR

Code Kod	Quantity Miktar	Picture Resim
CC-103-23.0	2 Pcs / Adet	
CC-103-09.6	2 Pcs / Adet	
CC-105-30.8	4 Pcs / Adet	
CC-105-04.6	4 Pcs / Adet	
CC-902-22.5	2 Pcs / Adet	
CC-903-22.5	2 Pcs / Adet	
EM58-21	2 Pcs / Adet	
EM58-22	4 Pcs / Adet	
MK-20.1	4 Pcs / Adet	

CONNECTIONS / BAĞLANTILAR

Code Kod	Quantity Miktar	Picture Resim
EM58T-403	1 Set / Takım	
EM54-C01	2 Pcs / Adet	

GASKETS / FİTİLLER

Code Kod	Quantity Miktar	Picture Resim
EM1-XX	4SL + 2SH	
EM2-03	4SL + 2SH	
EM54-01	1SL + 2SH	
EM3-01	1SL + 2SH	
PB-7-1000	2SL	

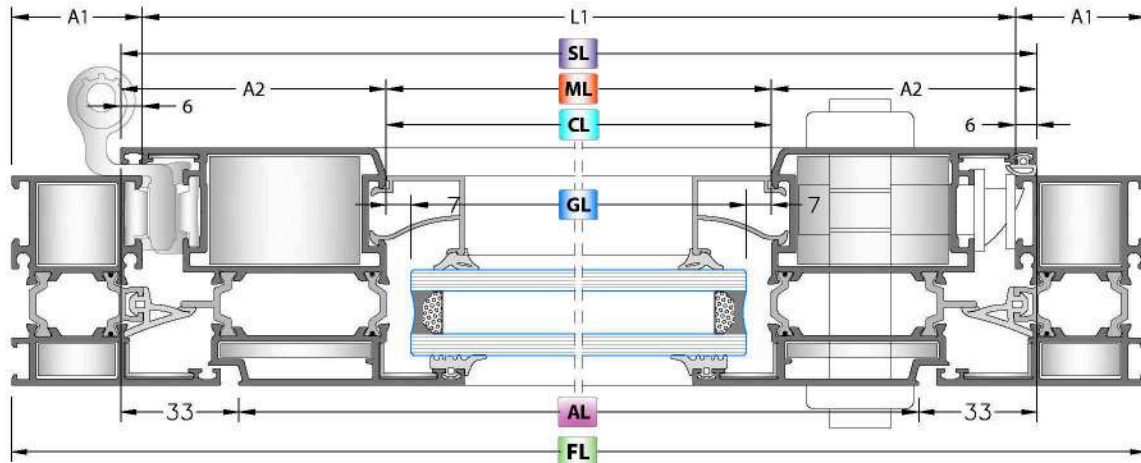
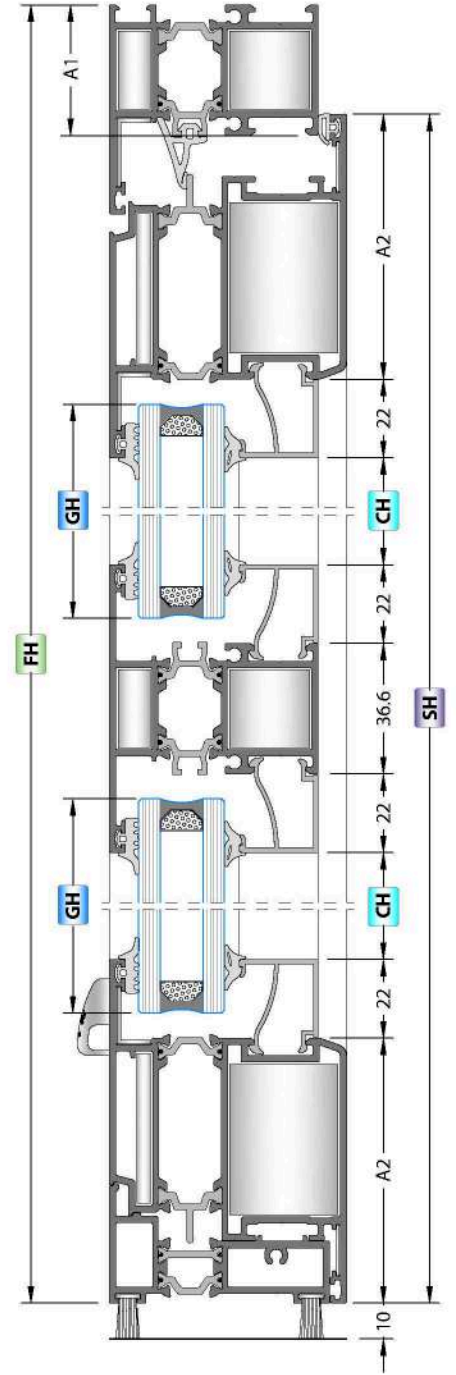

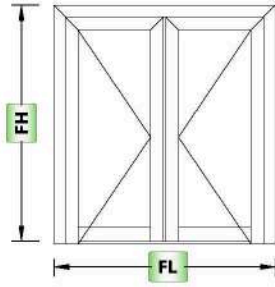

GLASS / CAM

Code Kod	Drawing Çizim	Quantity Miktar	Dimensions (mm) Boyutlar
Glass Cam		2 Pcs / Adet	GL = SL - (A2+A2) + 30 GH = SH - (A2+130) + 30

PROFILES / PROFİLLER

Code Kod	Drawing Çizim	Cut Kesim	Quantity Miktar	Dimensions (mm) Boyutlar
58T-102-18			1 Pcs / Adet	FL
			1 Pcs / Adet	FH
			1 Pcs / Adet	FH
58T-205-18			2 Pcs / Adet	$SL = \frac{FL - (A1+A1) + 7}{2}$
			2 Pcs / Adet	SH = FH - (A1+12) + 6
			2 Pcs / Adet	SH = FH - (A1+12) + 6
58T-501-18			1 Pcs / Adet	AH = SH - 35
58T-402-18			2 Pcs / Adet	ML = CL
08-109-00			4 Pcs / Adet	CL = SL - (A2+A2) + 44
			4 Pcs / Adet	CH = SH - (130+A2)
20-101-00			1 Pcs / Adet	L1

CONNECTIONS / BAĞLANTILAR

Code Kod	Quantity Miktar	Picture Resim
CC-103-23.0	2 Pcs / Adet	
CC-103-09.6	2 Pcs / Adet	
CC-105-23.6	4 Pcs / Adet	
CC-105-04.6	4 Pcs / Adet	
CC-902-65.7	2 Pcs / Adet	
CC-903-67.7	2 Pcs / Adet	
EM58-21	2 Pcs / Adet	
EM58-22	4 Pcs / Adet	
MK-20.1	4 Pcs / Adet	
EM58T-501	1 Set / Takım	

CONNECTIONS / BAĞLANTILAR

Code Kod	Quantity Miktar	Picture Resim
EM54-C01	2 Pcs / Adet	

GASKETS / FİTİLLER

Code Kod	Quantity Miktar	Picture Resim
EM1-XX	4SL + 4SH	
EM2-03	4SL + 4SH	
EM54-01	1SL + 3SH	
EM3-01	2SL + 3SH	
AKF-195 B	2SL	

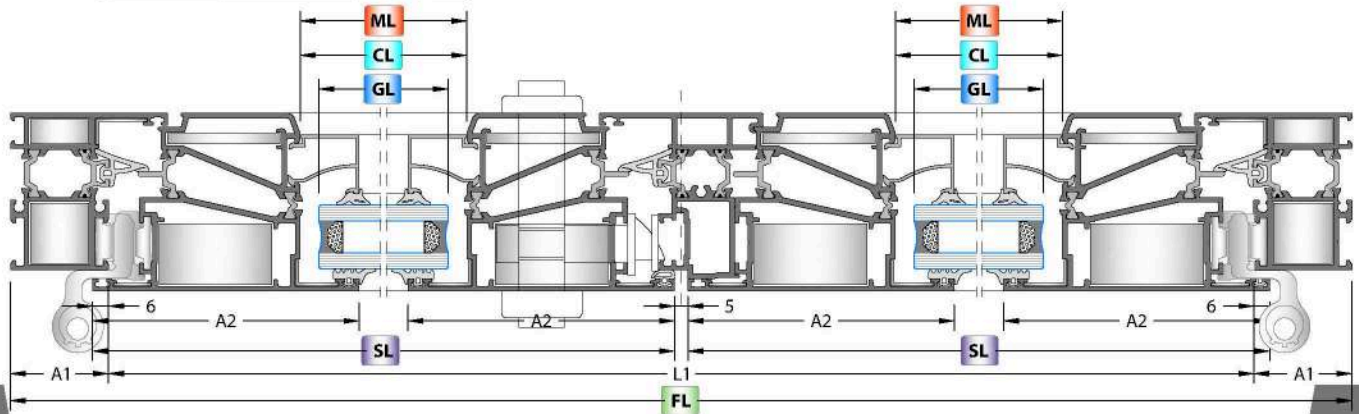
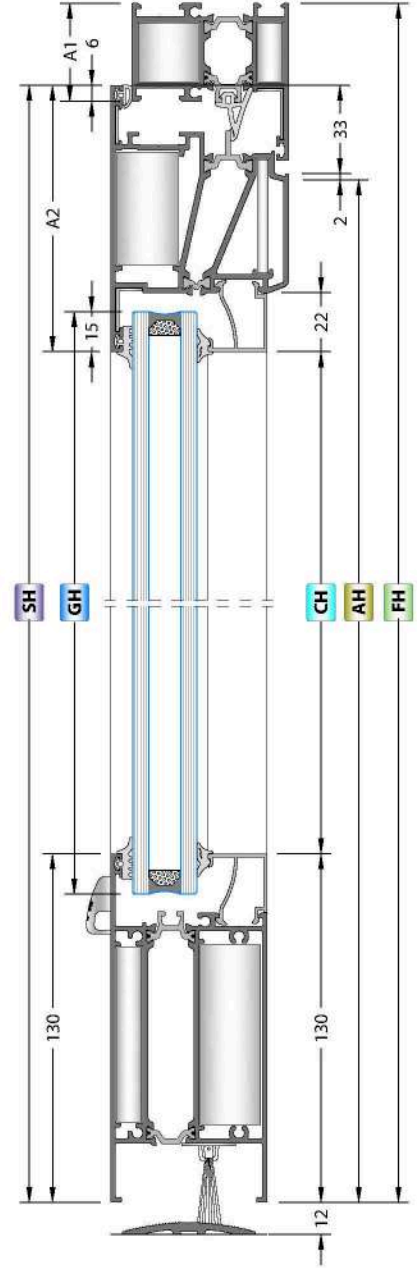

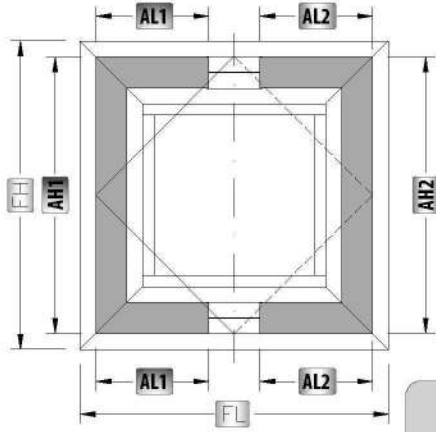

GLASS / CAM

Code Kod	Drawing Çizim	Quantity Miktar	Dimensions (mm) Boyutlar
Glass Cam		1 Pcs / Adet	GL = SL - (A2+A2) - 14 GH = SH - (A2+A2) - 14

PROFILES / PROFİLLER

Code Kod	Drawing Çizim	Cut Kesim	Quantity Miktar	Dimensions (mm) Boyutlar
58T-102-18			2 Pcs / Adet	FL
58T-302-18			2 Pcs / Adet	SL = FL - (A1+A1) - 54
			2 Pcs / Adet	SH = FH - (A1+A1) - 54
AL1 58T-503-18		Front View / Ön Görünüş 45° Plan View / Plan Görünüş 60°	2 Pcs / Adet	AL1 = $\frac{FL}{2}$ - 43.6 - A1
			1 Pcs / Adet	AH1 = FH - (A1+A1) + 12
AL2 58T-503-18		Front View / Ön Görünüş 45° Plan View / Plan Görünüş 60°	2 Pcs / Adet	AL2 = $\frac{FL}{2}$ - 43.6 - A1
			1 Pcs / Adet	AH2 = FH - (A1+A1) + 12
08-109-00			2 Pcs / Adet	CL = SL - (A2+A2)
			2 Pcs / Adet	CH = SH - (A2+A2+22+22)

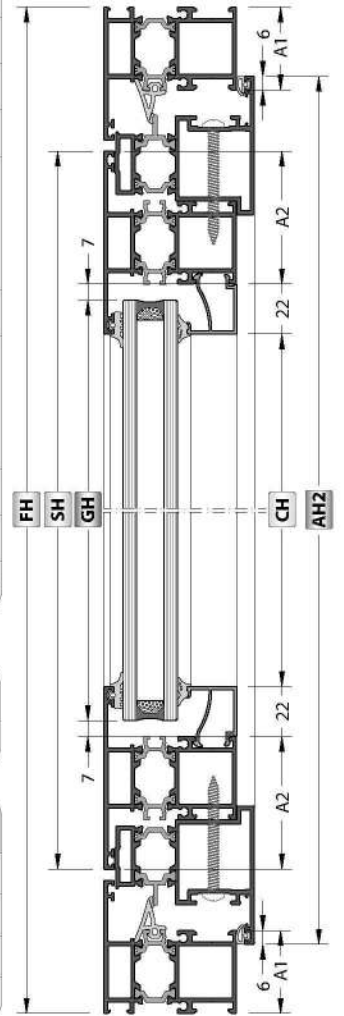
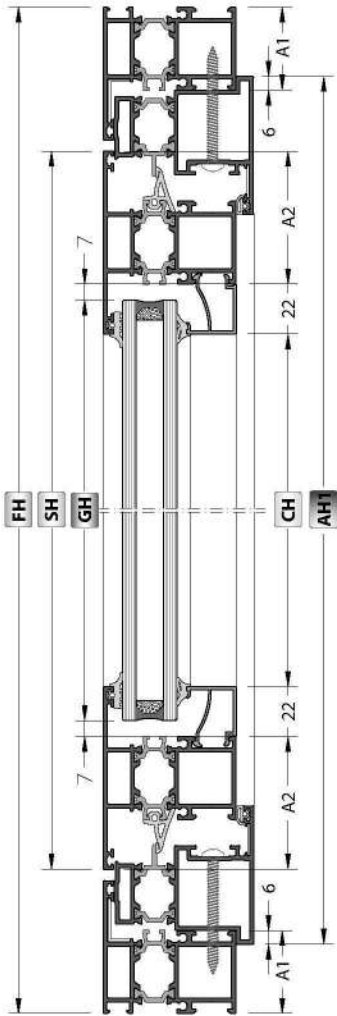

CONNECTIONS / BAĞLANTILAR

Code Kod	Quantity Miktar	Picture Resim
CC-103-23.0	8 Pcs / Adet	
CC-103-09.6	8 Pcs / Adet	
CC-123-31.0	4 Pcs / Adet	
CC-103-04.6	4 Pcs / Adet	
EM58-21	8 Pcs / Adet	
MK-20.1	4 Pcs / Adet	
EM54-C01	2 Pcs / Adet	

CONNECTIONS / BAĞLANTILAR

Code Kod	Quantity Miktar	Picture Resim
EM58-520	2 Pcs / Adet	

GASKETS / FITİLLER

Code Kod	Quantity Miktar	Picture Resim
EM1-XX	2SL + 2SH	
EM2-03	2SL + 2SH	
EM54-01	2SL + 2SH	
EM3-01	2SL + 2SH	

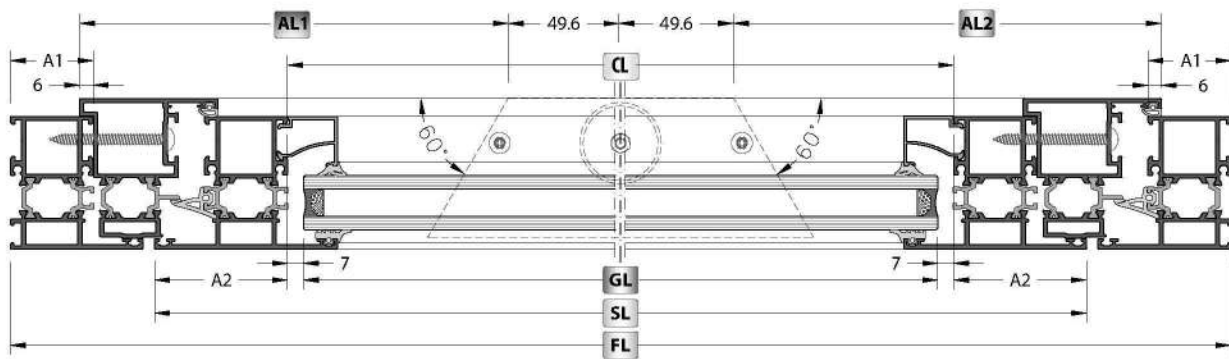

58T

ASSEMBLY DETAILS / MONTAJ DETAYLARI

FRAME ASSEMBLY / KASA UYGULAMA

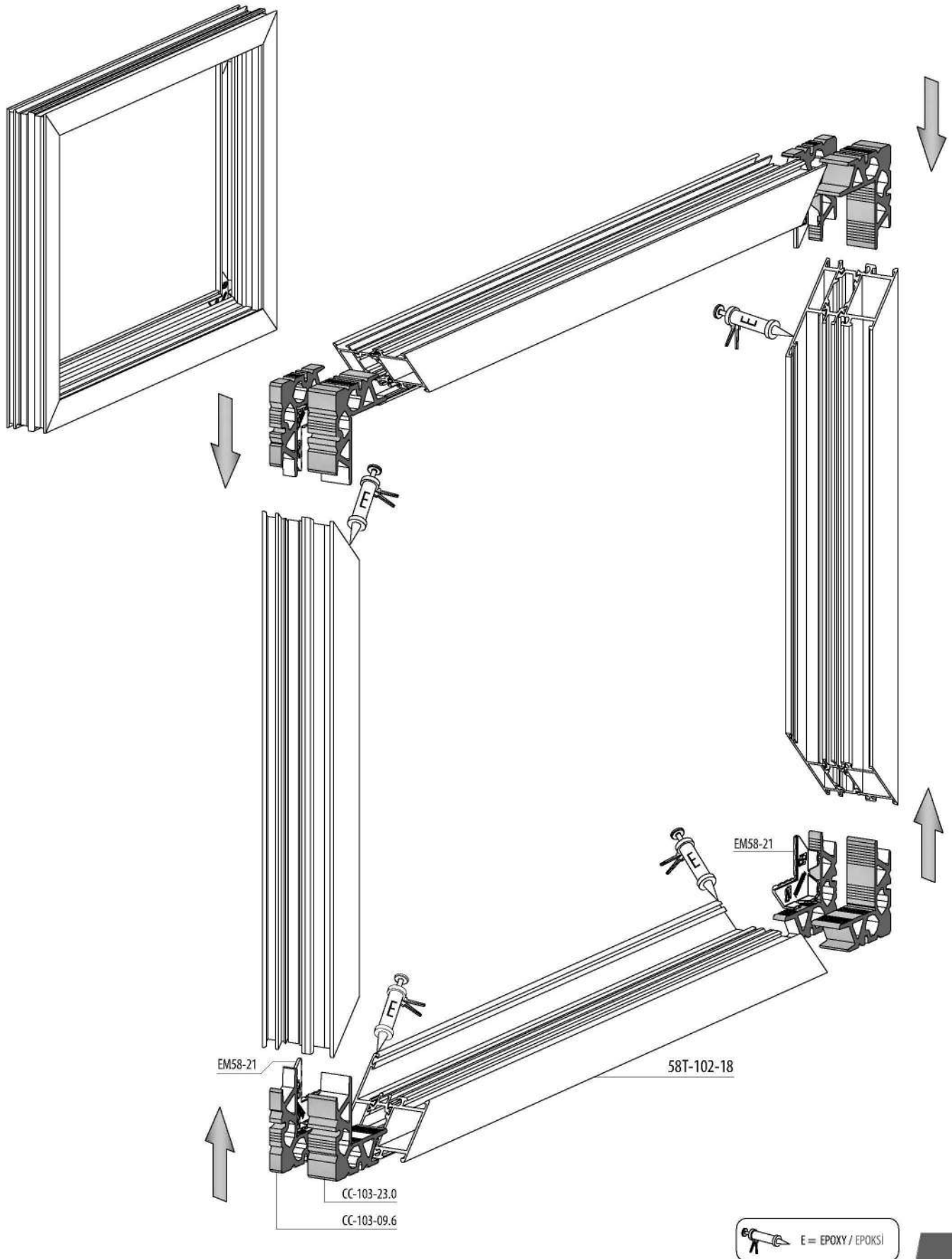

SASH ASSEMBLY / KANAT UYGULAMA

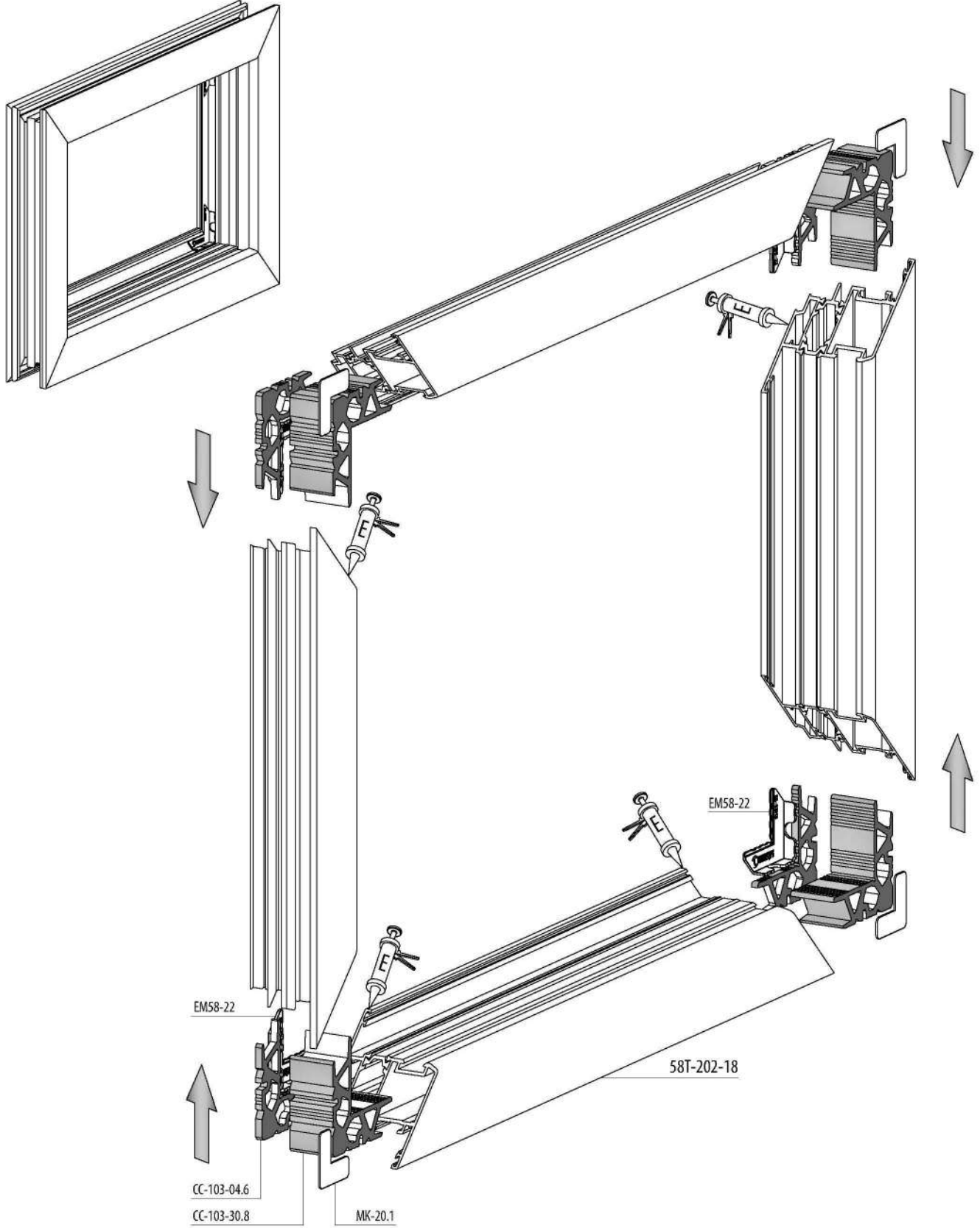

 E = EPOXY / EPOKSI

CENTRAL GASKET ENJECTION CORNER
TOZLUK FİTİLİ ENJEKSİYON KÖŞE

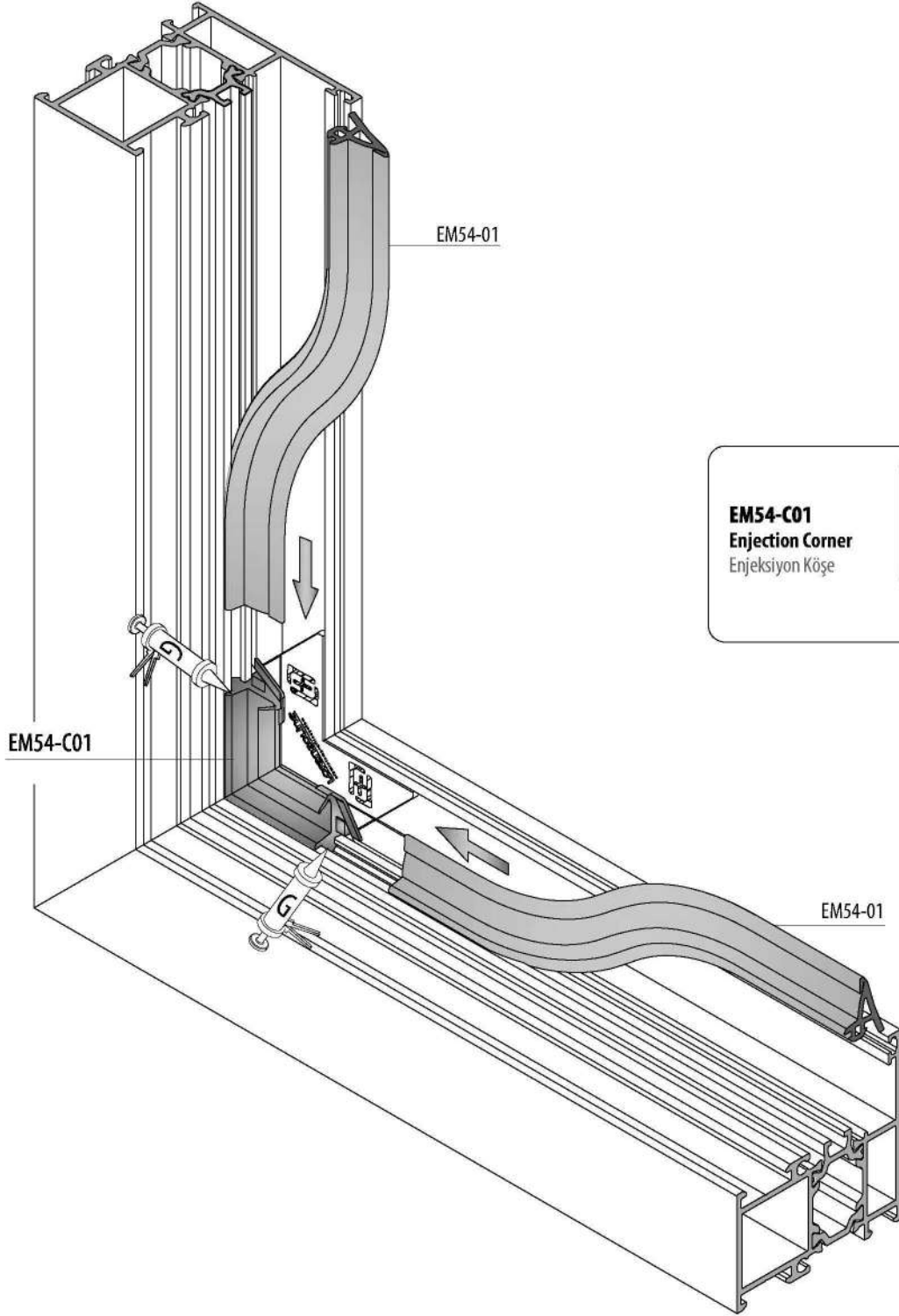

EM54-C01
Enjection Corner
Enjeksiyon Köşe



 G = EPDM GLUE
EPDM YAPIŞTIRICI

GLAZING BEAD APPLICATION TYPES / CAM ÇITA UYGULAMA ÇEŞİTLERİ

Vertical / Düşey : Flat - Düz
Horizontal / Yatay : Flat - Düz

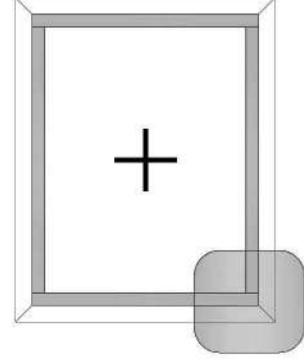
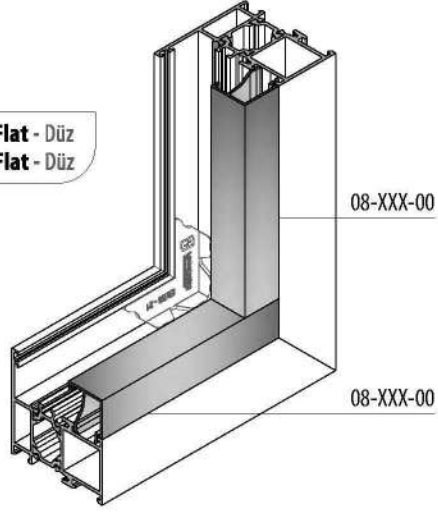

Vertical / Düşey : Oval
Horizontal / Yatay : Flat - Düz

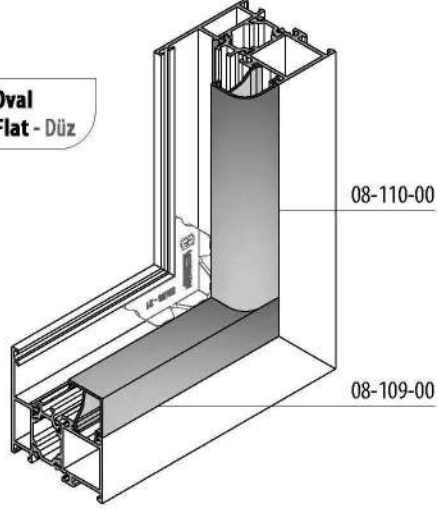

Vertical / Düşey : Flat - Düz
Horizontal / Yatay : Oval

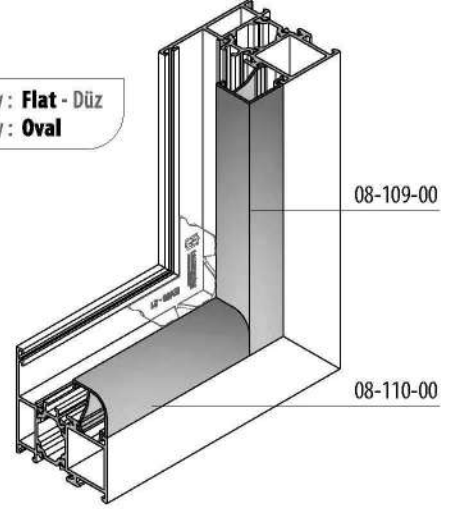

Vertical / Düşey : Oval
Horizontal / Yatay : Oval

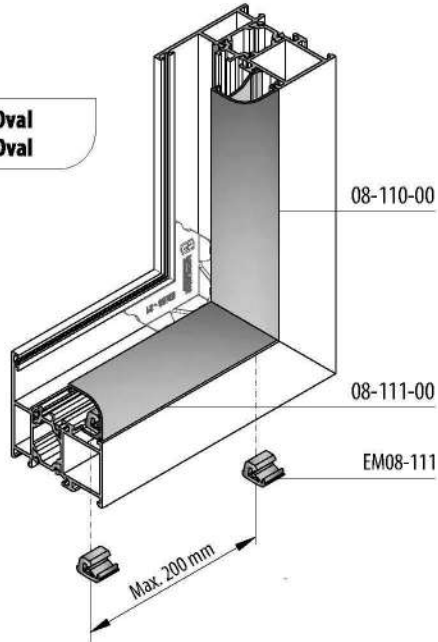

Vertical / Düşey : Oval
Horizontal / Yatay : Oval

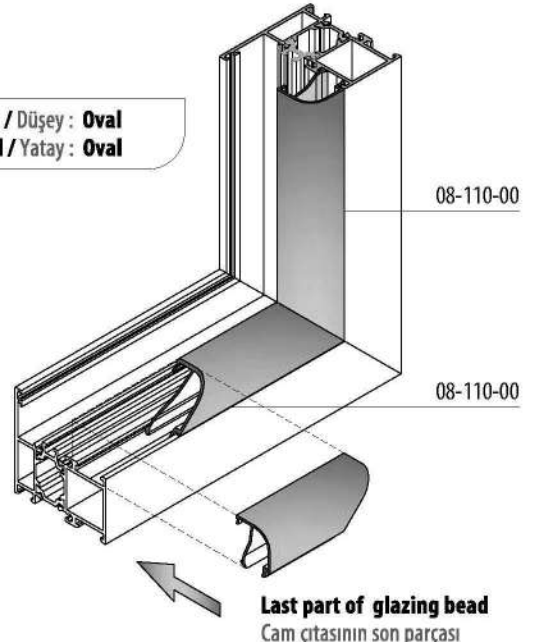

DRANAIGE HOLES / TAHLİYE DELİKLERİ

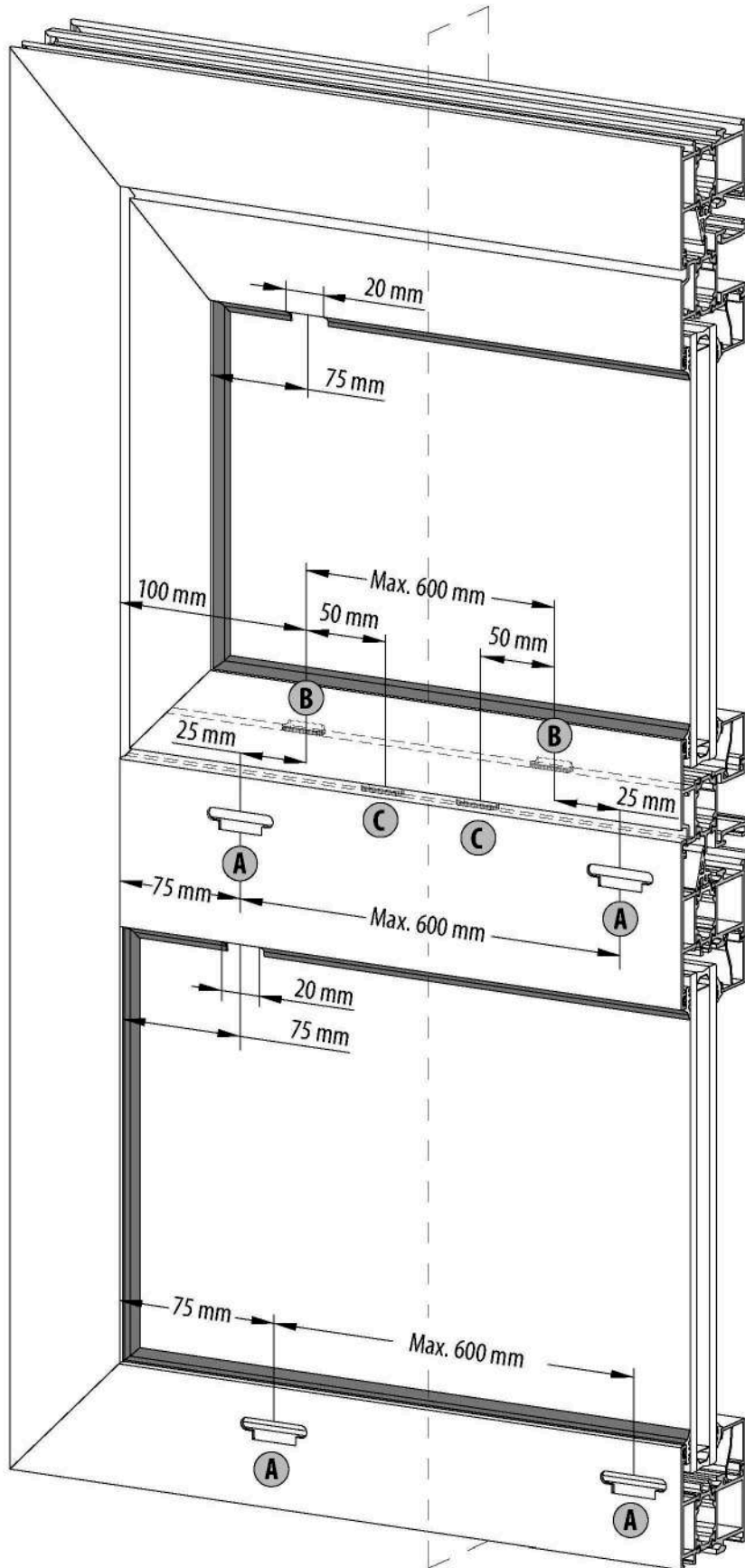

A

SLOT DIMENSIONS / SLOK ÖLÇÜLERİ

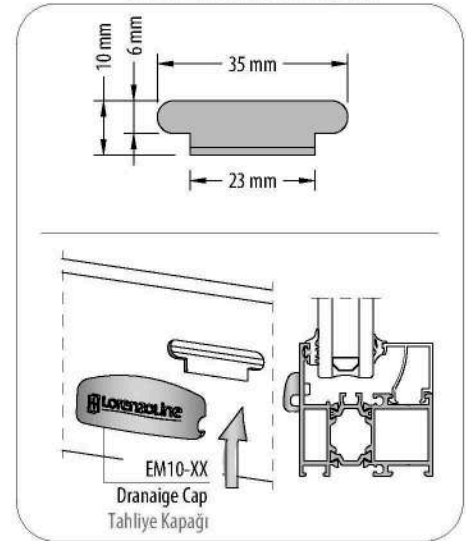

B

SLOT DIMENSIONS / SLOK ÖLÇÜLERİ

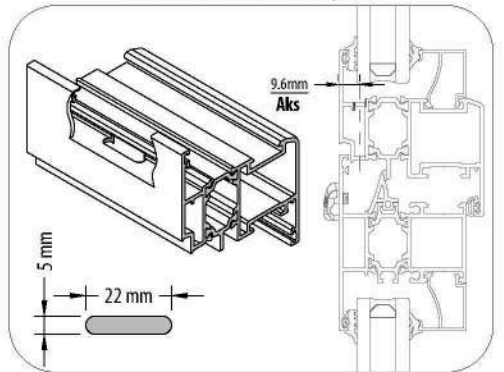

C

SLOT DIMENSIONS / SLOK ÖLÇÜLERİ

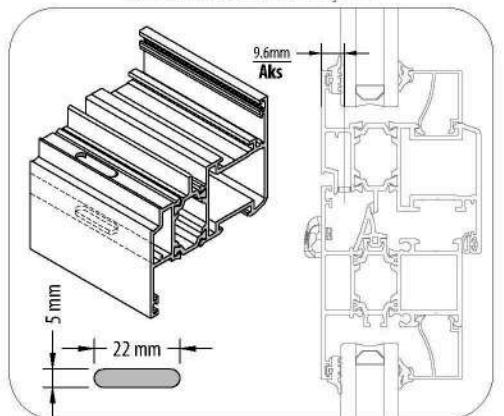

DOUBLE SASH ADAPTER CAP / ÇİFT KANAT ADAPTÖR

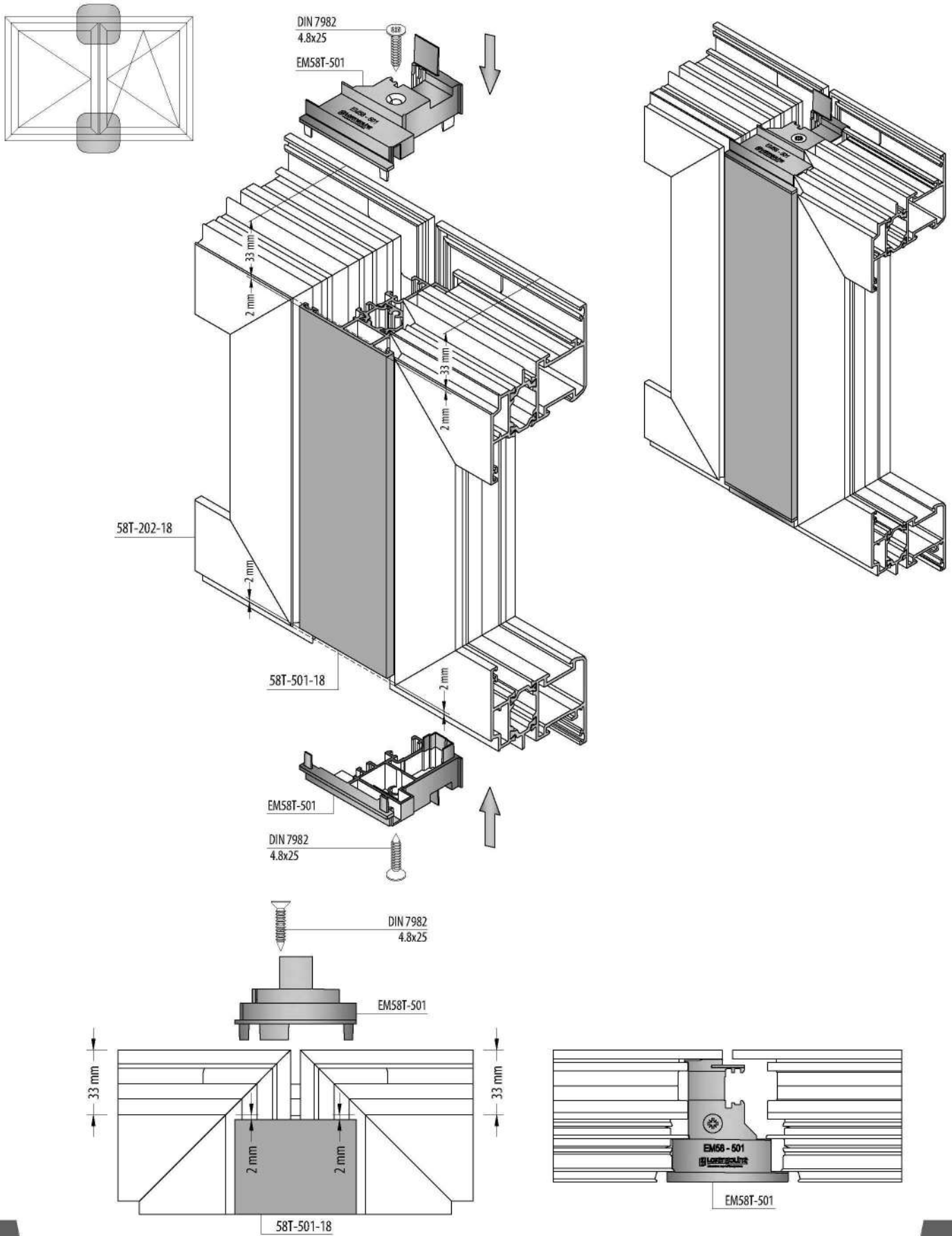

MULLION CUTTING KNIFE / ORTA KAYIT KESME BIÇAĞI

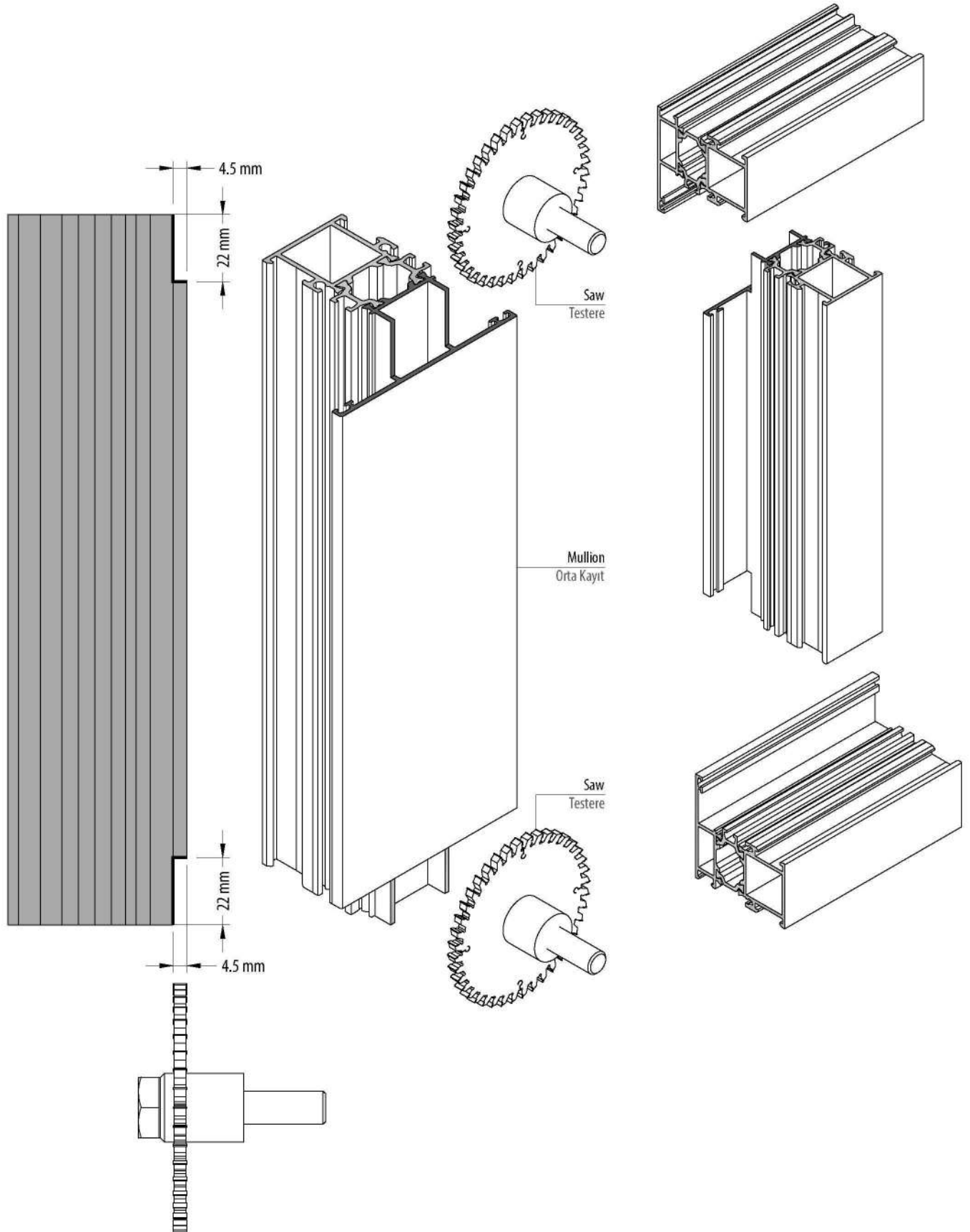

MULLION ISOLATION / ORTA KAYIT İZOLASYONU



Isolation Before Montage
Montaj Öncesi İzolasyon

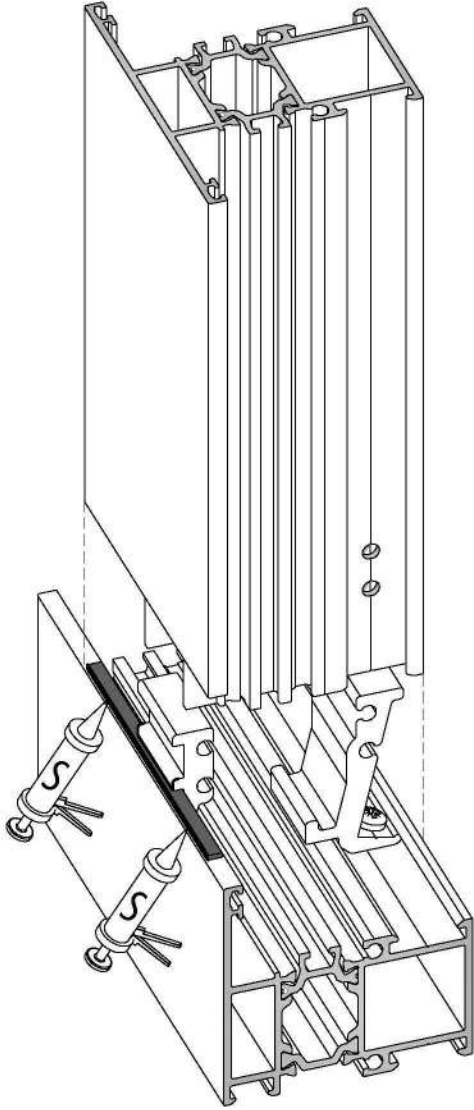

Isolation After Montage
Montaj Sonrası İzolasyon

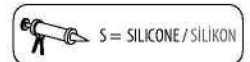
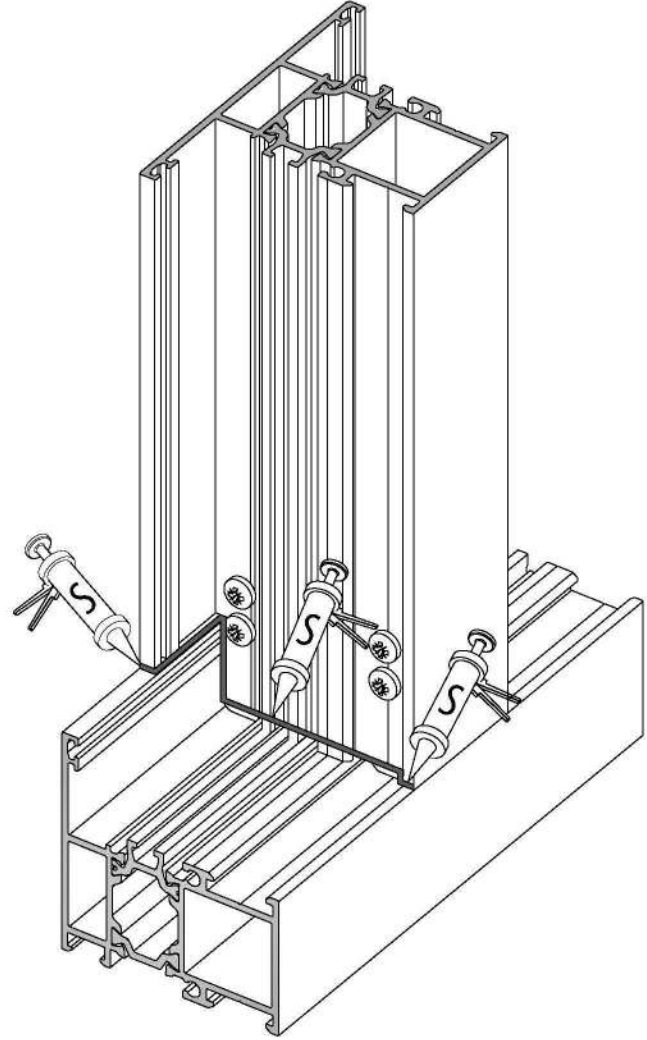

MULLION MONTAGE WITH T JUNCTION / ÇEKTİRME BAĞLANTI İLE ORTA KAYIT MONTAJI

Montage to Frame / Kasaya Montaj

Holes Sizes
Delik Ölçüleri

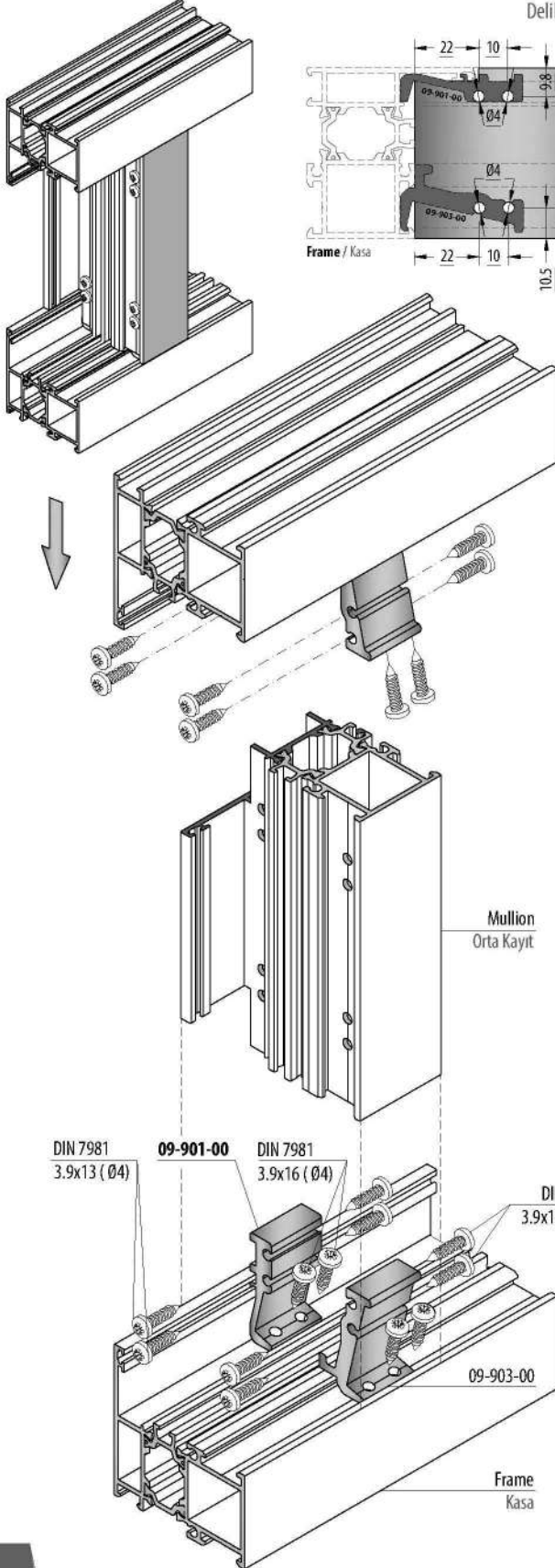
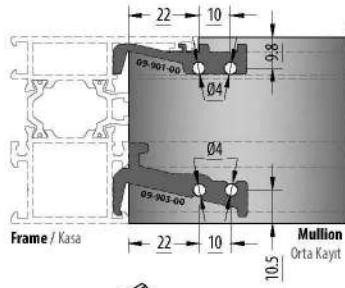

Montage to Sash / Kanat'a Montaj

Holes Sizes
Delik Ölçüleri

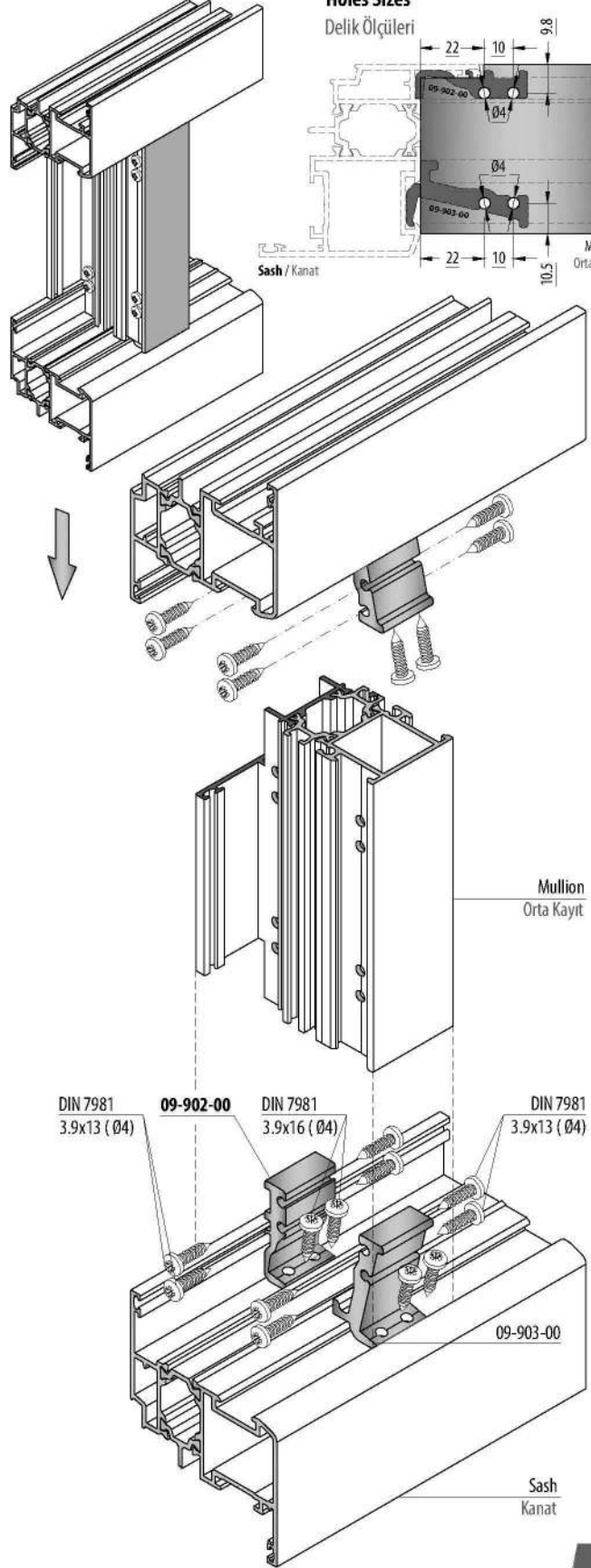
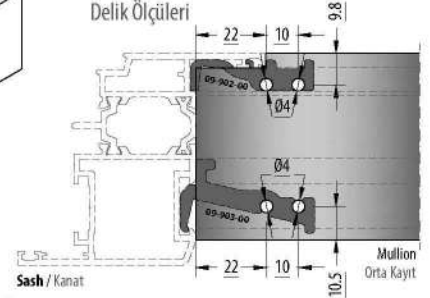

MULLION MONTAGE WITH SCREW / VİDA İLE ORTA KAYIT MONTAJI

Montage to Frame / Kasaya Montaj

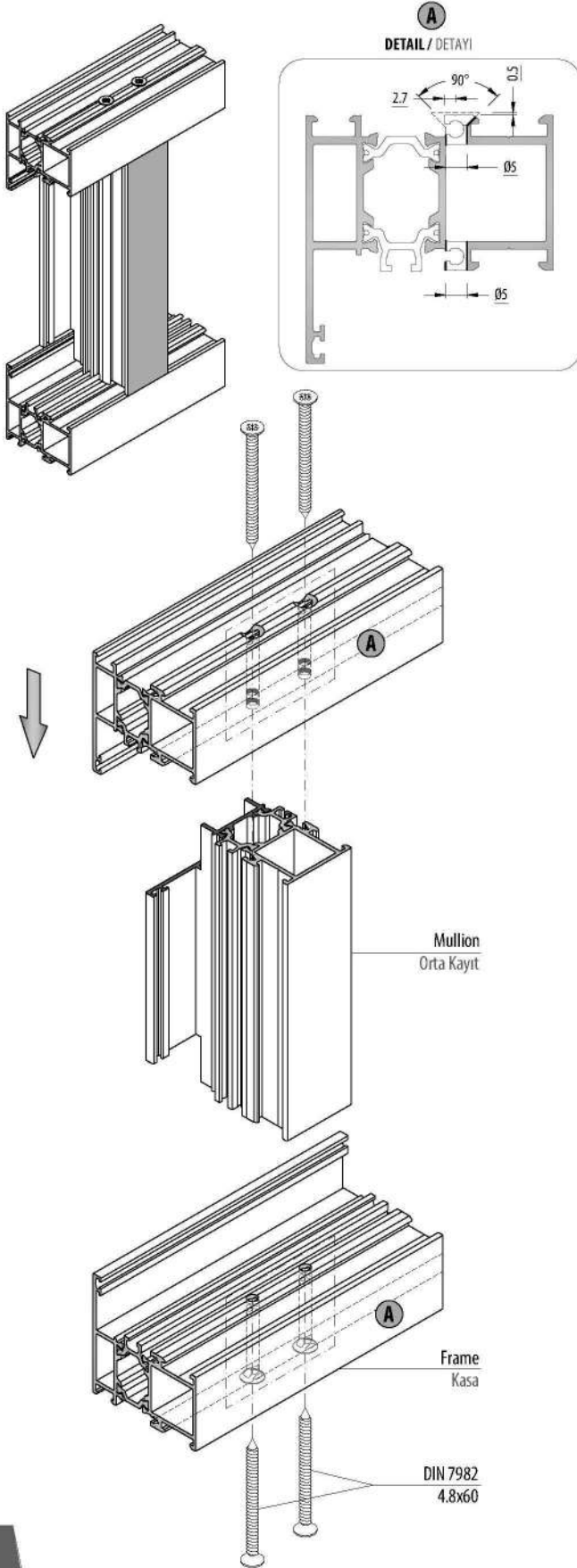

Montage to Sash / Kanat'a Montaj

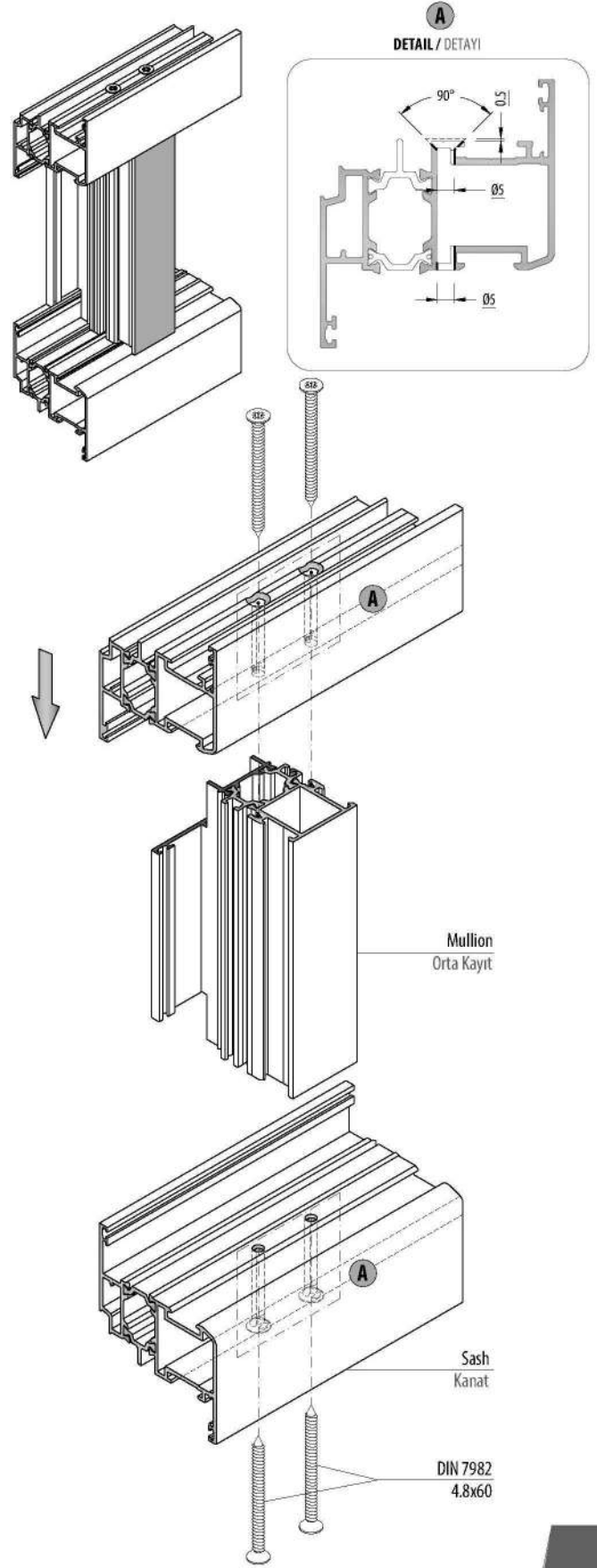

MULLION MONTAGE WITH SCREW / VIDA İLE ORTA KAYIT MONTAJI

SCREW SIZES / VIDA ÖLÇÜLERİ

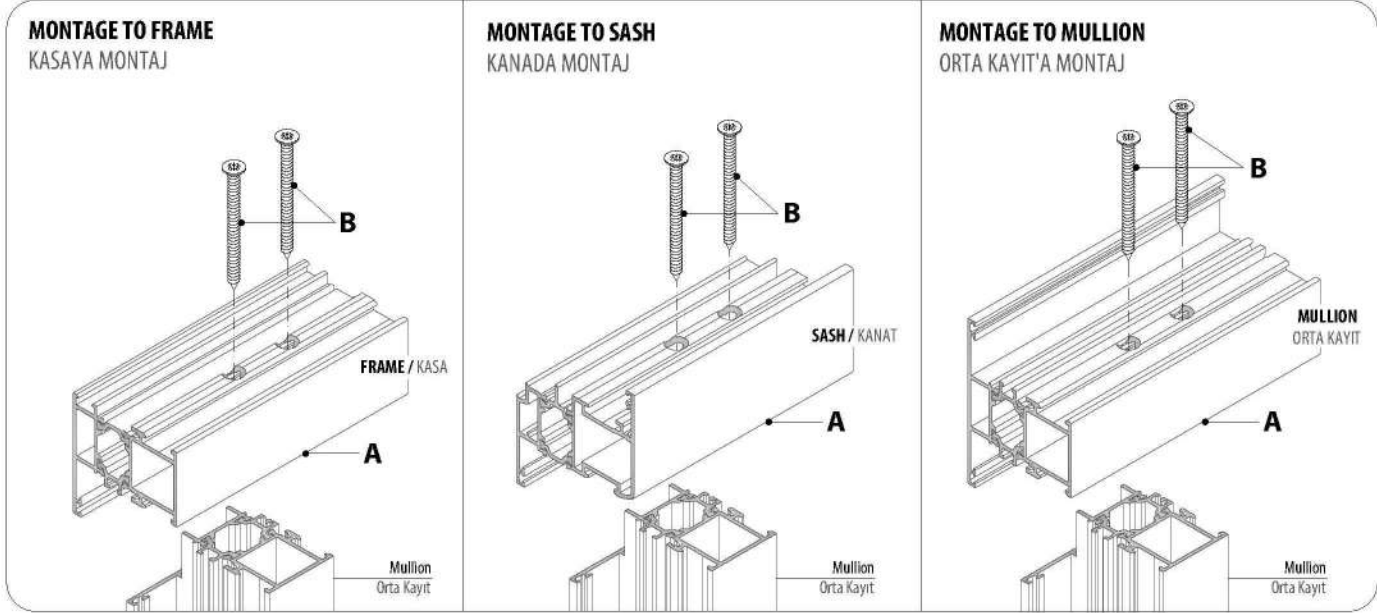

A	B	
PROFILE CODE PROFİL KODU	SCREW VIDA	
58T-102-18	YHB 4.8x60 DIN 7982	
58T-102-15		
58T-112-15		
58T-122-18		
58T-132-18		
58T-103-18		
58T-113-18		
58T-133-18		
58T-104-18		YHB 4.8x70 DIN 7982
58T-105-18		YHB 4.8x100 DIN 7982

A	B
PROFILE CODE PROFİL KODU	SCREW VIDA
58T-201-18	YHB 4.8x38 DIN 7982
58T-201-15	
58T-201-20	
58T-202-18	YHB 4.8x50 DIN 7982
58T-202-15	
58T-202-20	
58T-203-18	YHB 4.8x60 DIN 7982
58T-204-18	YHB 4.8x70 DIN 7982
58T-204-15	
58T-204-20	
58T-205-18	YHB 4.8x80 DIN 7982
58T-205-15	
58T-205-20	
58T-206-18	YHB 4.8x90 DIN 7982
58T-207-18	YHB 4.8x50 DIN 7982
58T-252-18	
58T-252-15	
58T-256-18	YHB 4.8x90 DIN 7982

A	B
PROFILE CODE PROFİL KODU	SCREW VIDA
58T-301-18	YHB 4.8x38 DIN 7982
58T-301-15	
58T-301-20	
58T-306-18	YHB 4.8x50 DIN 7982
58T-302-18	YHB 4.8x60 DIN 7982
58T-302-15	
58T-302-20	
58T-303-18	YHB 4.8x70 DIN 7982
58T-304-18	YHB 4.8x80 DIN 7982
58T-304-15	
58T-305-18	YHB 4.8x100 DIN 7982
58T-312-18	YHB 4.8x60 DIN 7982
58T-312-15	
58T-322-18	

MULLION MONTAGE WITH SCREW / VİDA İLE ORTA KAYIT MONTAJI

MULLION AKS DIMENSION / ORTA KAYIT AKS ÖLÇÜLERİ

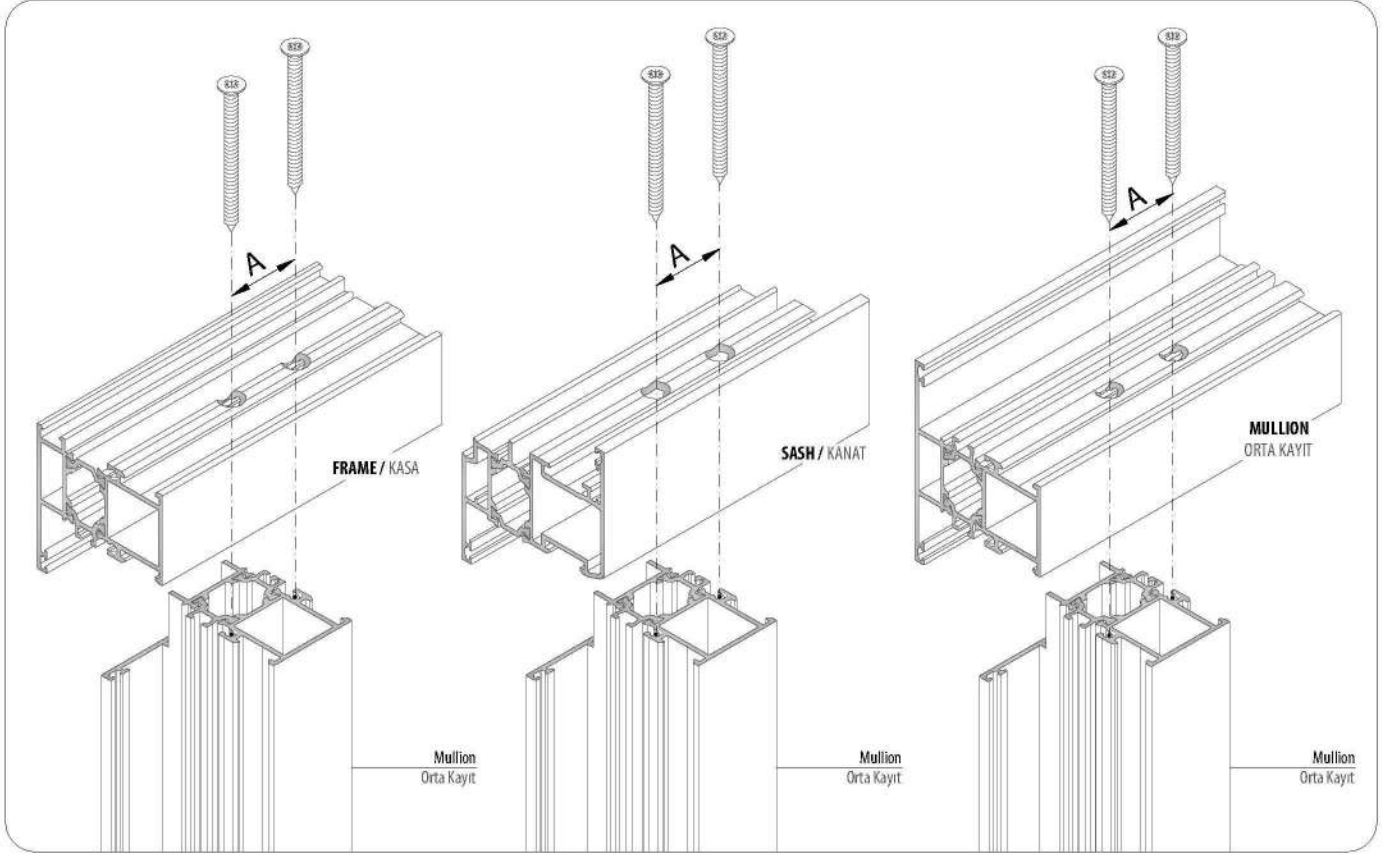

PROFILE CODE PROFİL KODU	A
	CENTER DIMENSION VİDA AKS ÖLÇÜLERİ
58T-301-18	18 mm
58T-301-15	
58T-301-20	
58T-306-18	24.9 mm
58T-302-18	30 mm
58T-302-15	
58T-302-20	
58T-312-18	
58T-312-15	
58T-322-18	

PROFILE CODE PROFİL KODU	A
	CENTER DIMENSION VİDA AKS ÖLÇÜLERİ
58T-303-18	39.9 mm
58T-304-18	50.3 mm
58T-304-15	
58T-305-18	79.4 mm

KICK PLATE CAP MONTAGE / ETEK KAPAK MONTAJI

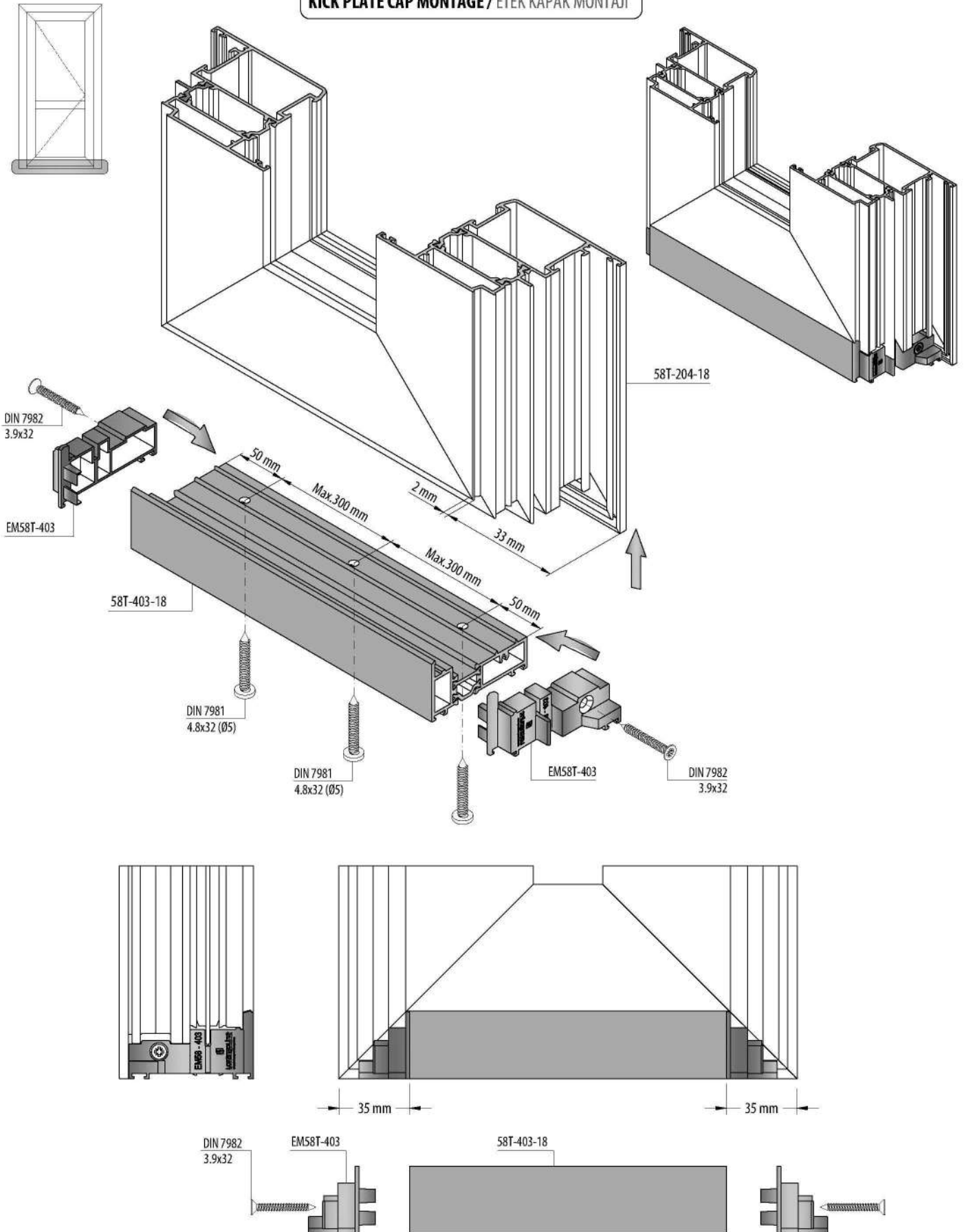

KICK PLATE MONTAGE WITH T JUNCTION / ÇEKTİRME BAĞLANTI İLE ETEK MONTAJI

Montage to Frame / Kasaya Montaj

Montage to Sash / Kanat'a Montaj

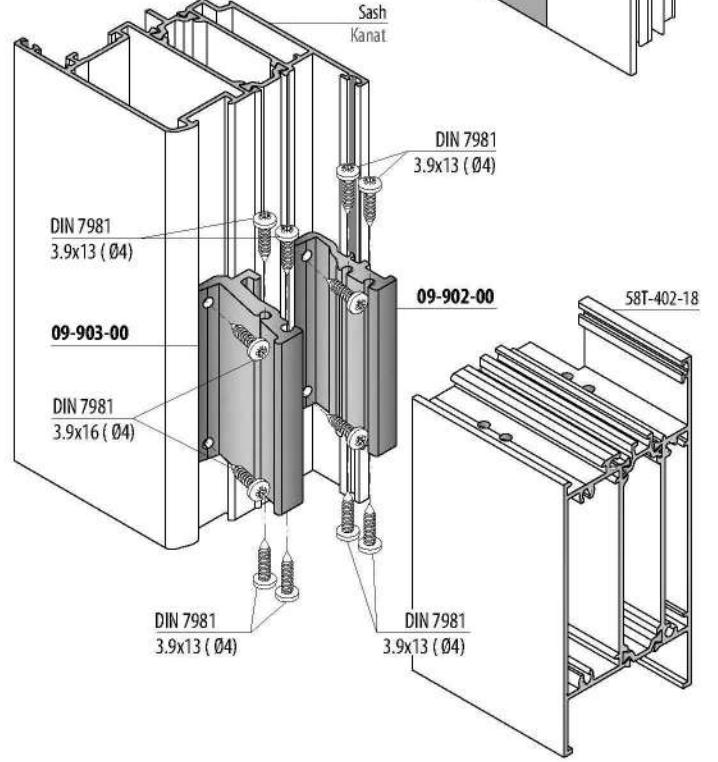
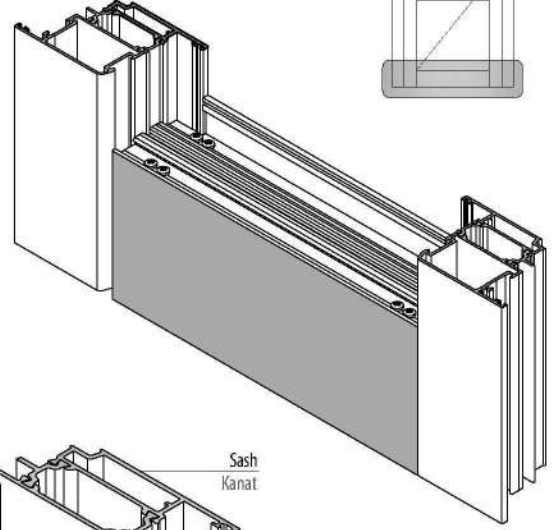
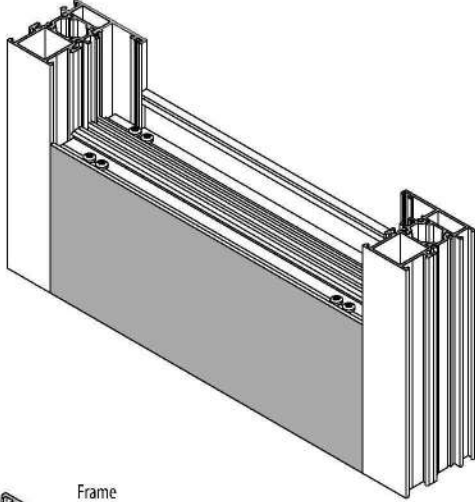
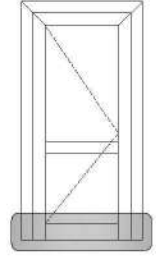
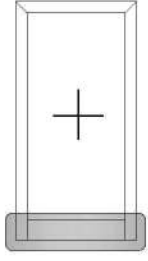

Holes Sizes
Delik Ölçüleri

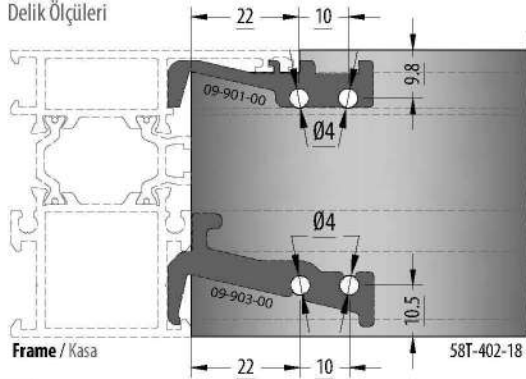

Holes Sizes
Delik Ölçüleri

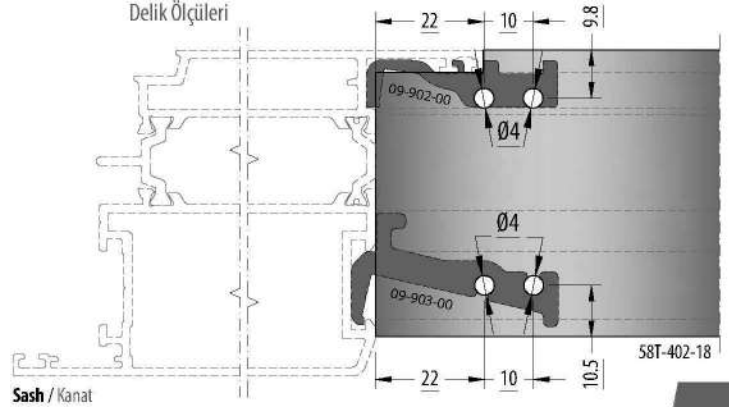

KICK PLATE CAP MONTAGE WITH SCREW / ETEK KAPAĞI İLE VIDA MONTAJI

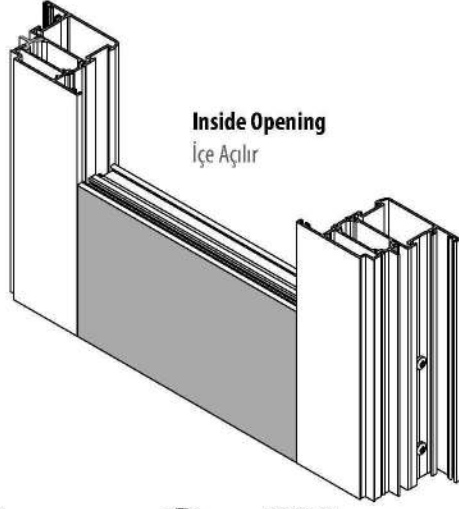
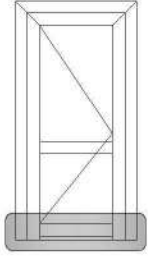

Inside Opening
İçe Açılır

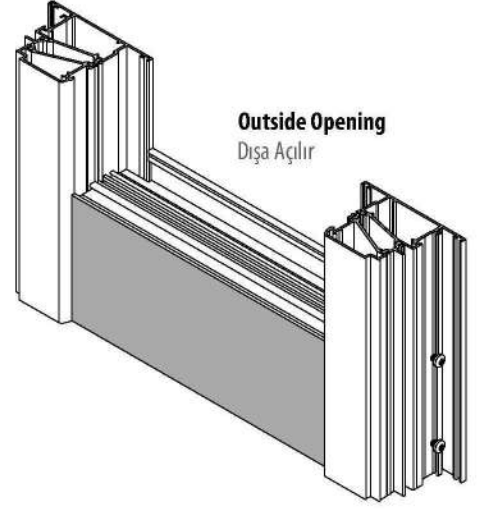

Outside Opening
Dışa Açılır

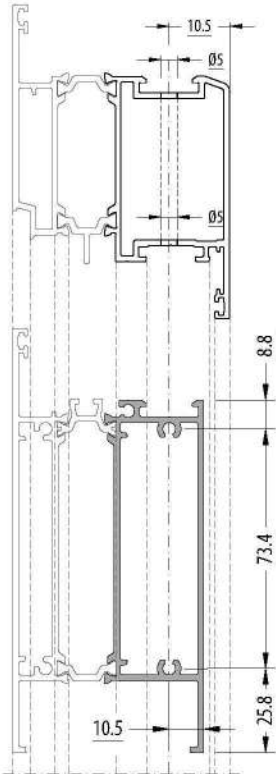
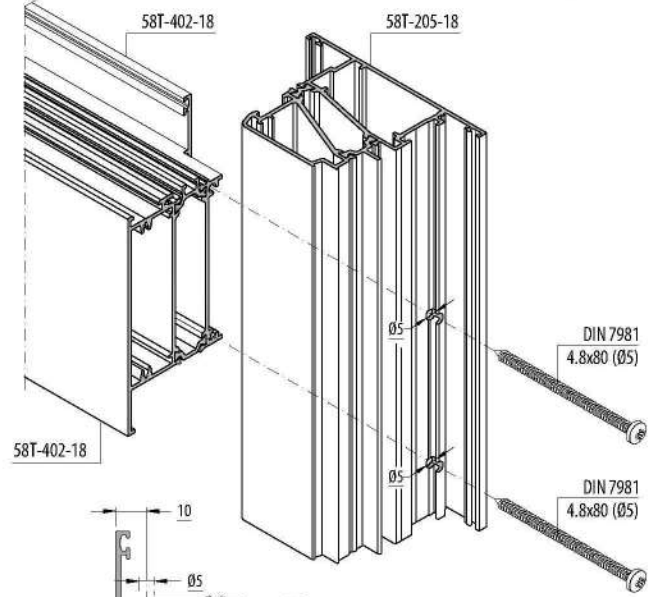
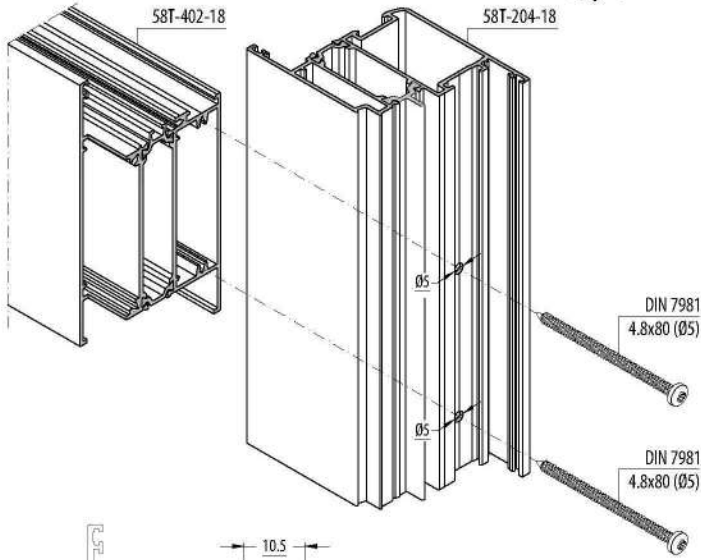

Screw Sizes / Vida Ölçüleri

PROFILE CODE PROFİL KODU	SCREW VIDA
58T-204-18	DIN 7981 4.8x80
58T-204-15	
58T-204-20	
58T-206-18	DIN 7981 4.8x90
58T-256-18	

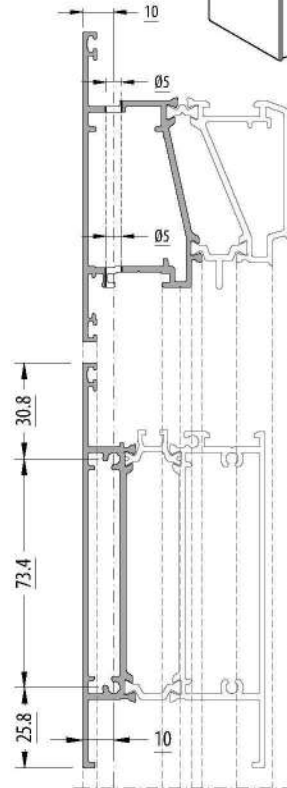

Screw Sizes / Vida Ölçüleri

PROFILE CODE PROFİL KODU	SCREW VIDA
58T-205-18	DIN 7981 4.8x80
58T-205-15	
58T-205-20	
58T-207-18	DIN 7981 4.8x90

DOOR SASH DROPPER MONTAGE / KAPI KANADI DAMLALIK MONTAJI

Inside Opening / İçe Açılır

Outside Opening / Dışa Açılır

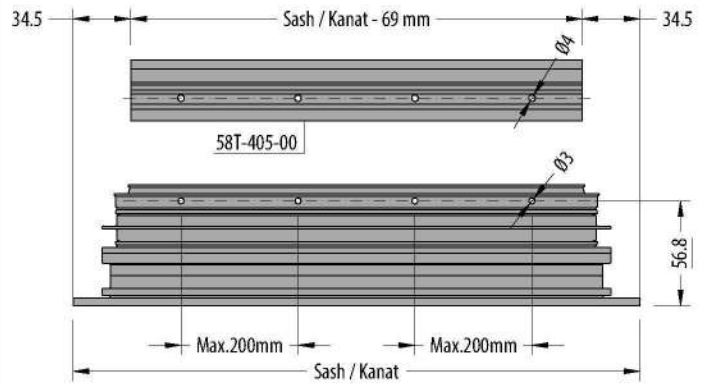
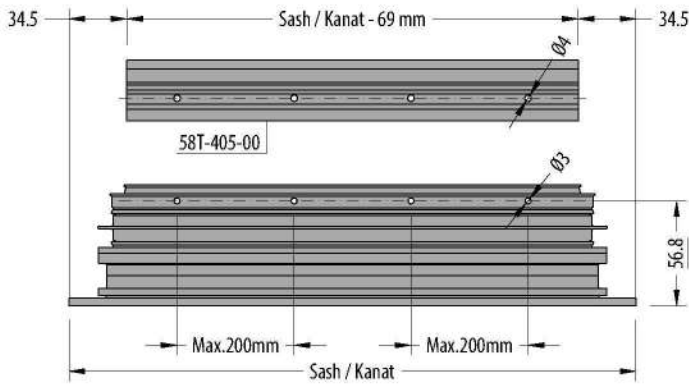
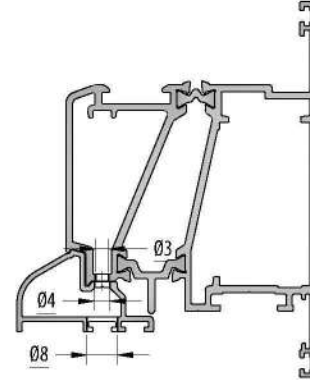
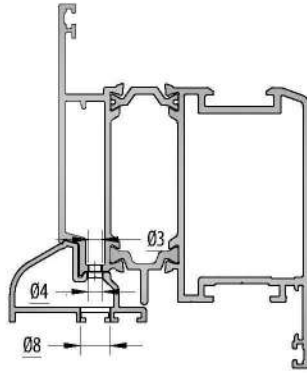
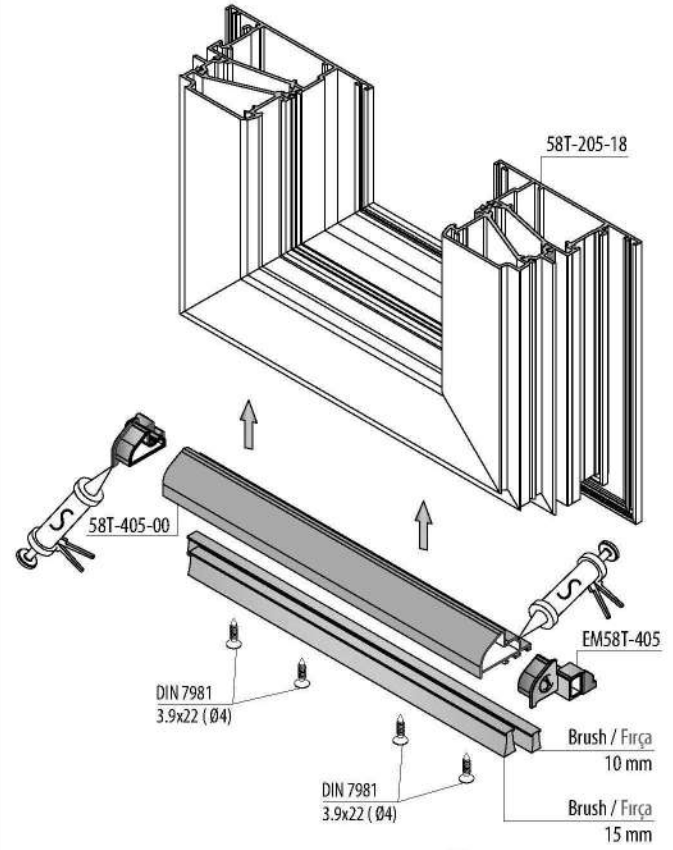
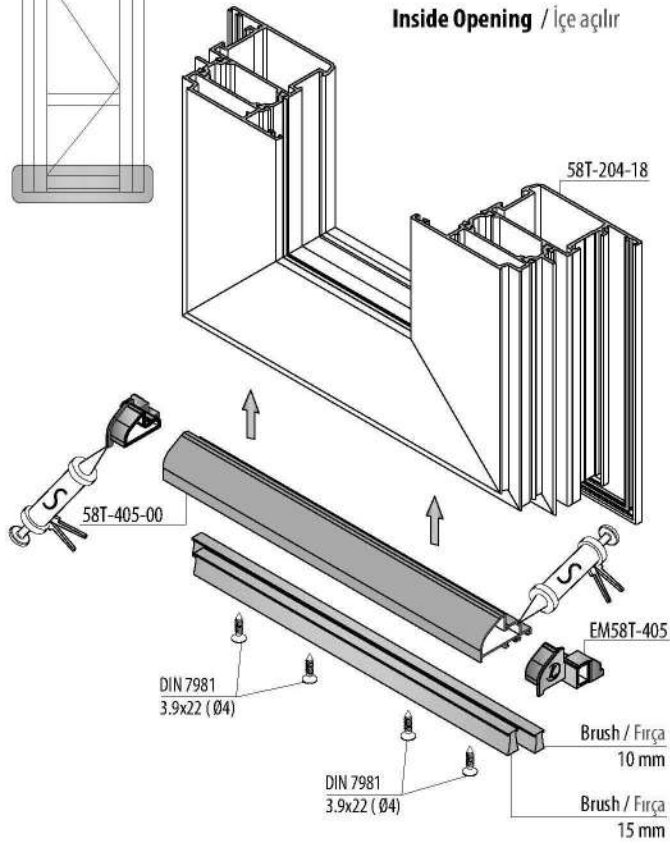
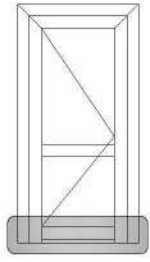

S = SILICONE / SİLİKON

FRAME KICK PLATE MONTAGE / KASA İLE ETEK MONTAJI

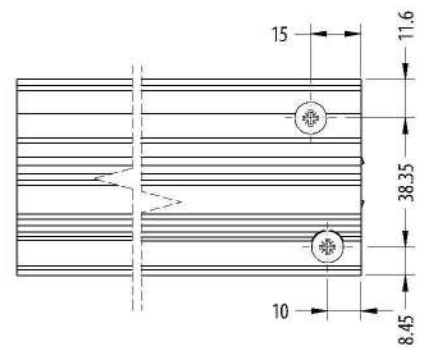
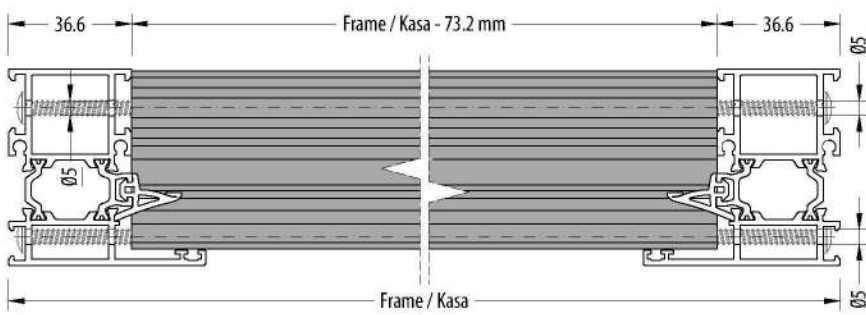
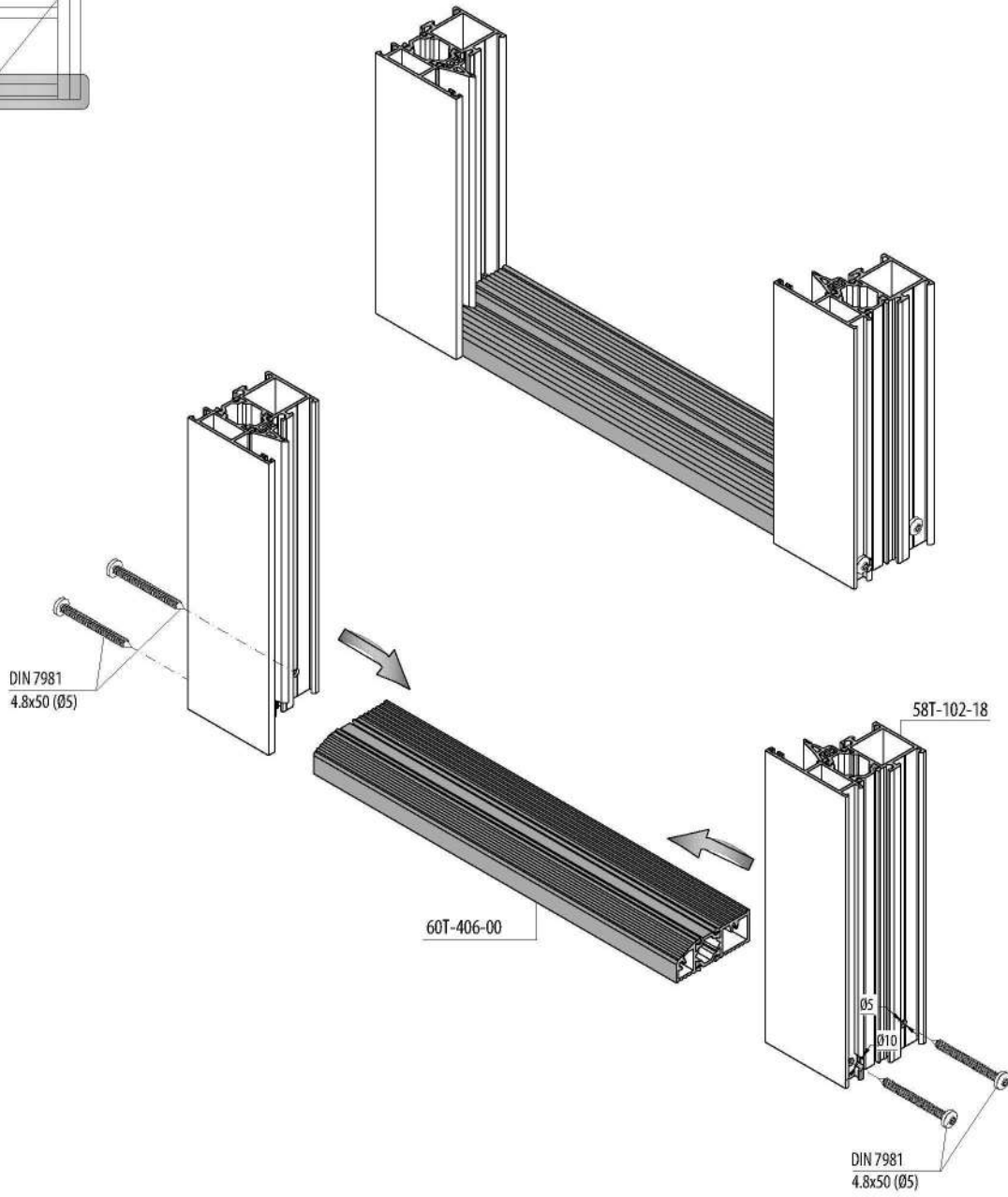
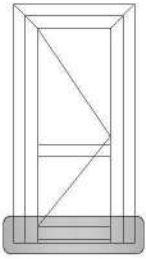

PIVOT OPENING ASSEMBLY / PİVOT AÇILIM UYGULAMASI

Frame Assembly / Kasa Uygulaması

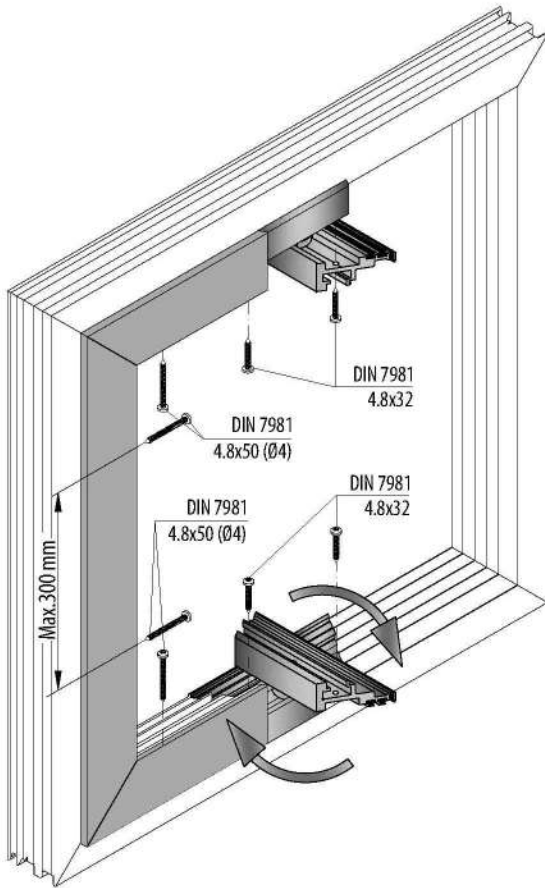
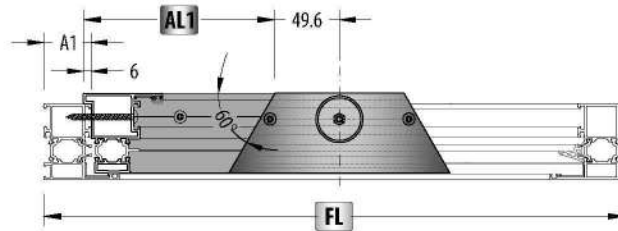
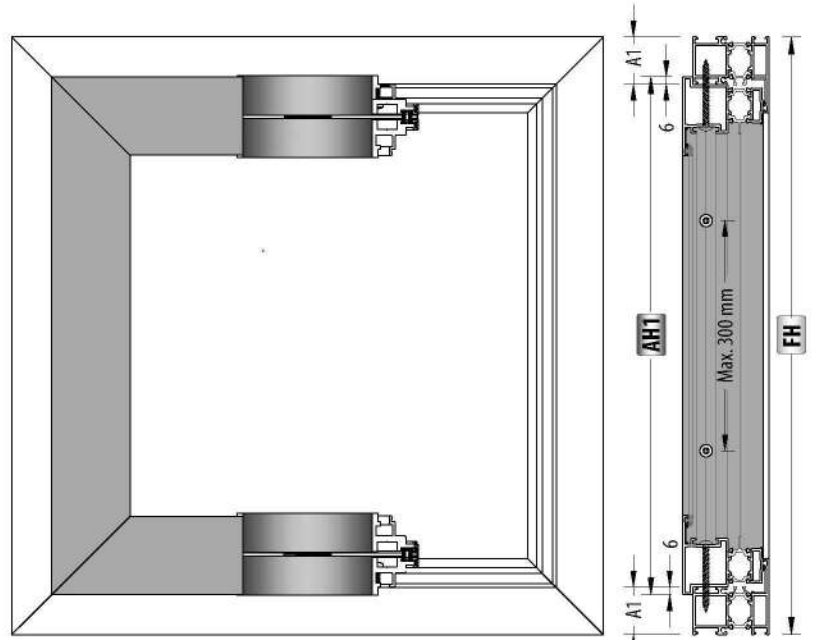
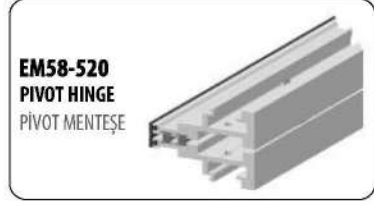
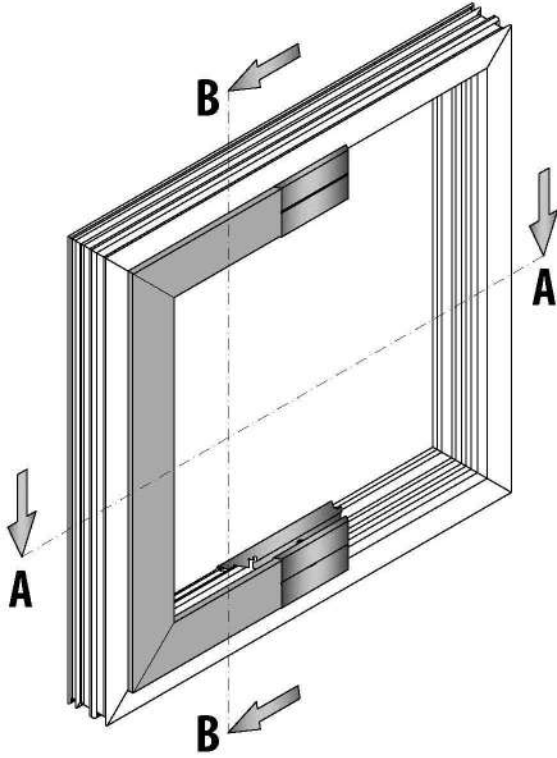

PROFILES / PROFİLLER

Code Kod	Drawing Çizim	Cut Kesim	Quantity Miktar	Dimensions (mm) Boyutlar
58T-102-18			2 Pcs / Adet	FL
			2 Pcs / Adet	FH
AL1 58T-503-18		Front View / Ön Görünüş 	2 Pcs / Adet	$AL1 = \frac{FL}{2} - 43.6 - A1$
		Plan View / Plan Görünüş 		
			1 Pcs / Adet	$AH1 = FH - (A1 + A1) + 12$

PIVOT OPENING ASSEMBLY / PİVOT AÇILIM UYGULAMASI

Frame - Sash Assembly / Kasa - Kanat Uygulaması

- * Pivot hinge sash side should be open position.
- * Sash module should slide to frame module and hinge should screw to sash module.
- * Pivot menteşe kanat kısmı açık hale getirilir.
- * Kanat modülü, kasa modülünün içerisine sürülür ve menteşe kanat modülüne vidalanır.

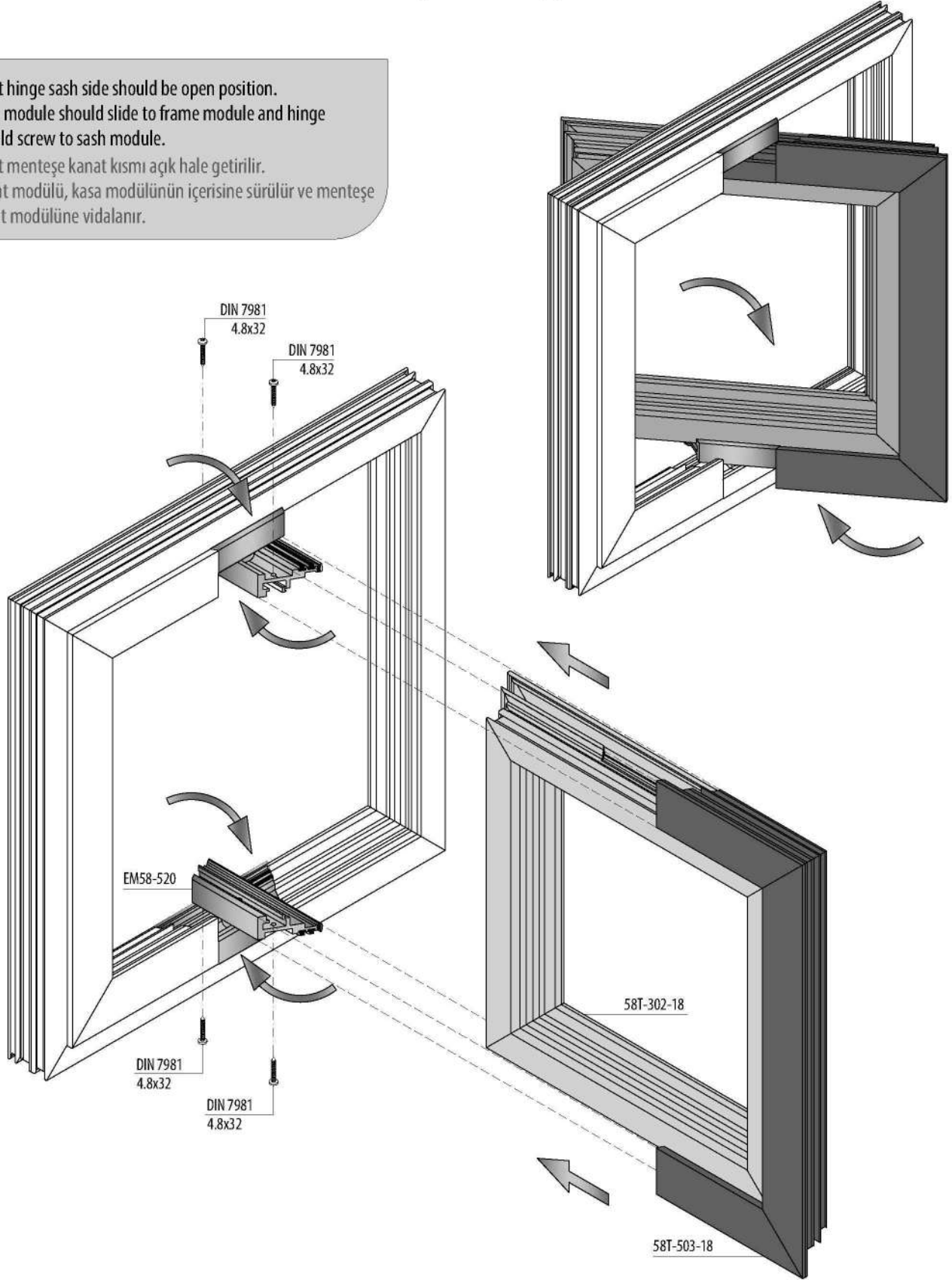

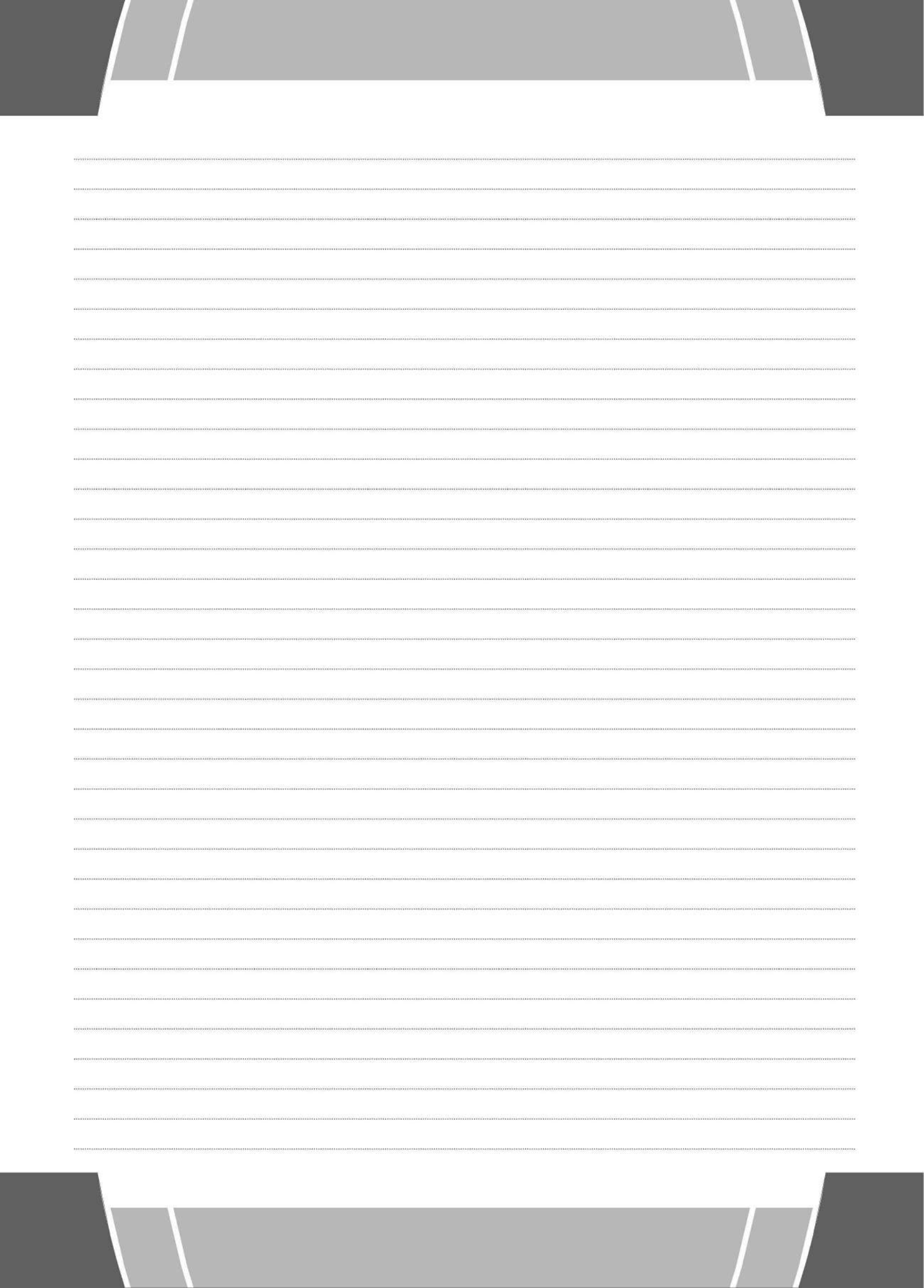



KURTOĞLU BAKIR KURŞUN SANAYİ A.Ş.
Velimeşe Organize Sanayi Bölgesi Akbayır Yolu
Küme Evler No: 81 Ergene 59851 Tekirdağ / Türkiye
T: 0 282 684 70 00 F: 0 282 684 70 01
www.kurtogluas.com