



 LORENZOLINE

70LS

Lift & Slide System | Kaldır & Sür Sistemi

TECHNICAL INFORMATION
TEKNİK BİLGİLER

LIFT & SLIDE VARIETIES / KALDIR & SÜR SEÇENEKLERİ

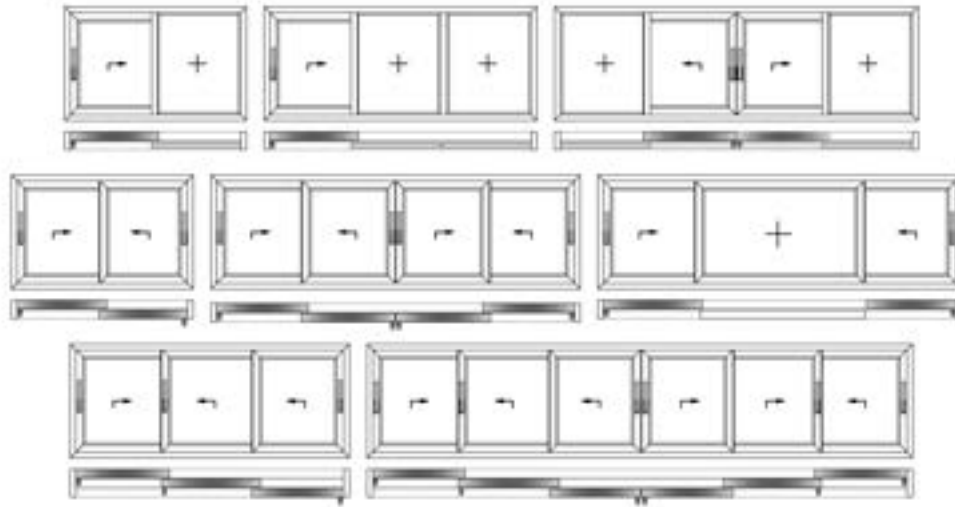

70LS LIFT & SLIDE SYSTEM

- Combination opportunity with single, two and three rail frames.
- Economic lift and slide solution with single rail frame.
- Low air permeability with EPDM gasket.
- Sash weight capacity is up to 400 kg.

70LS KALDIR & SÜR SİSTEM

- Tekli, ikili ve üçlü kasa tipleri sayesinde kombinasyon çeşitliliği.
- Tekli kasa sayesinde ekonomik Kaldır-Sür çözümü.
- EPDM fitiller sayesinde düşük hava geçirgenliği.
- 400 kg a kadar kanat ağırlık kapasitesi.

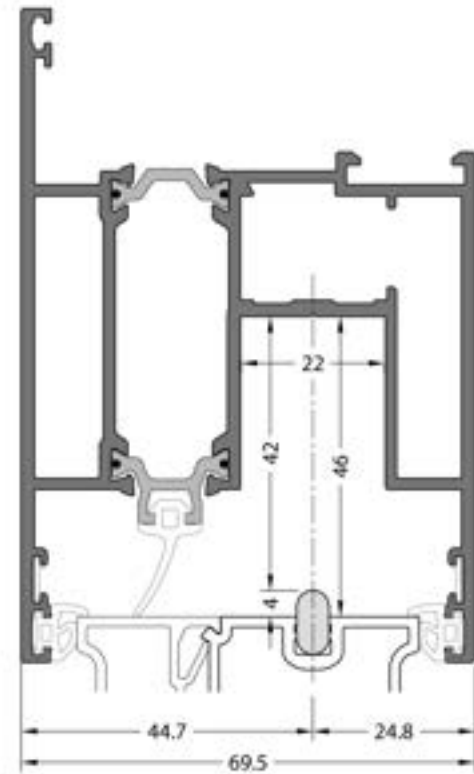
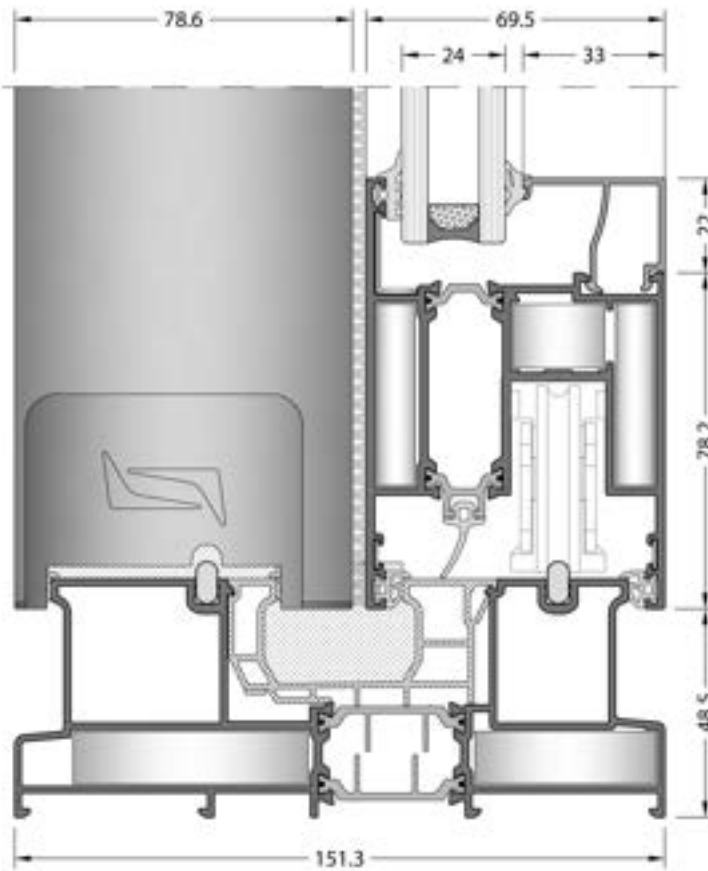

Univesal Lift & Slide Accesories Groove
Universal Kaldır-Sür Aksesuar Kanalı

systemproperties / sistembilgisi

Construction Depth	Vent : 69,5 mm	Derinlik	Kanat : 69,5 mm
Glazing	Glazing from 18 mm up to 50 mm with dry EPDM gaskets. The choice of joits and glazing beads depend on the thickness of the glass. According to the tolerances of the glazing either a smaller or bigger joint and or glazing bead is used.	Cam Kalınlığı	Cam kalınlığı EPDM fitil ile birlikte 18 mm 50 mm aralıktadır. Bağlantı ve çta cam kalınlığına göre seçilmelidir. Cam toleransına göre küçük yada büyük bağlantı veya cam çtası kullanılır.
Insulation Bar Thermal Permability	18 / 34 mm Uf = 2,56 ~ 4,59 W / m2K	Isı Bariyeri Isı Geçirgenliği	18 / 34 mm Uf = 2,56 ~ 4,59 W / m2K
Connections	Press corner joints and mechanical corner joint can apply for fixing corners. The mullions and transoms fix with T junction.	Bağlantılar	Köşeyi birleştirmek için pres ve mekanik köşe bağlantılar uygulanabilir. Orta kayıt birleşimlerinde T bağlantı kullanılır.
Gaskets	All system gaskets are made from EPDM rubber.	Fitil	Sistemin tüm fitilleri EPDM'dir.

productionproperties / üretimbilgisi

	The aluminium profiles have been extruded from the alloy EN-AW 6063 according to the EN-AW 6060.		Alüminyum profiller EN-AW 6063 alaşımından ve EN-AW 6060 standardına göre üretilir.
	Physical Properties		Fiziksel Özellikler
	1. Density : 2.70 Kg / dm3		1. Yoğunluk : 2.70 Kg / dm3
	2. Modules of Elasticity : 69 kN / mm2		2. Elastisite Modülü : 69 kN / mm2
	3. Resistivity : 20 ^o 33 n Ω .m		3. Direnç : 20 ^o 33 n Ω .m
Alloy	4. Melting point : 600 - 655 °C	Alaşım	4. Erime Noktası : 600 - 655 °C
	5. Linear expansion coefficient : 20 - 100°C μ °C ⁻¹		5. Genişleme Katsayısı : 20 - 100°C μ °C ⁻¹
	Mechanical Properties		Mekanik Özellikler
	1. Tensile strength : Min 215 MPa		1. Kopma Dayanıklılığı : Min 215 MPa
	2. Yield strength : 190 MPa		2. Elastisite Limiti : 190 MPa
	3. Elongation : % 10		3. Uzama : % 10
	4. Hardness : 67 Brinell		4. Sertlik : 67 Brinell
	Anodising		Eloksal
	In anodising process , microns of the profiles for the inside and outside use are different. The complete anodisation process takes place in accordance with the specifications of QUALANOD .		Eloksal projesinde profil mikronları iç ve dış kullanım için farklıdır. Bütün eloksal projesi QUALANOD spesifikasyonlarına göre uygulanır.
Surface Treatment	Electrostatic Powder Coating	Yüzey İşlem	Elektrostatik Toz Boya
	The thermal break allows the profile to be painted when compounded. On average, the coating thickness is minimally 60 micron. The complete powder coating process takes place in accordance with the specifications of QUALICOAT SEASIDE .		Isı bariyeri çakıldığında profil boyanabilir. Genel olarak kaplama kalınlığı minimum 60 mikrondur. Bütün toz boya projesi QUALICOAT SEASIDE spesifikasyonlarına göre uygulanır.

STATIC DIAGRAM / STATİK DİYAGRAM

Building Height / Bina yüksekliği 8 Meter / Metre - 0,5 kN/m² - Sehim 200

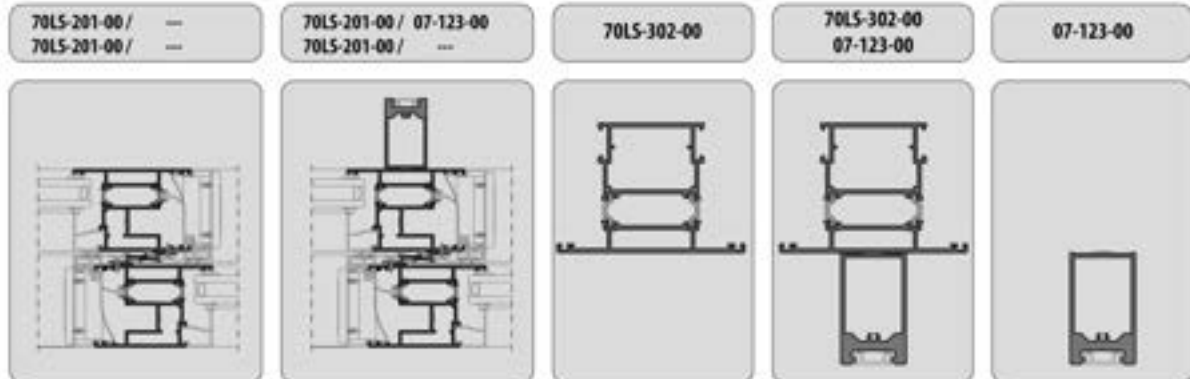
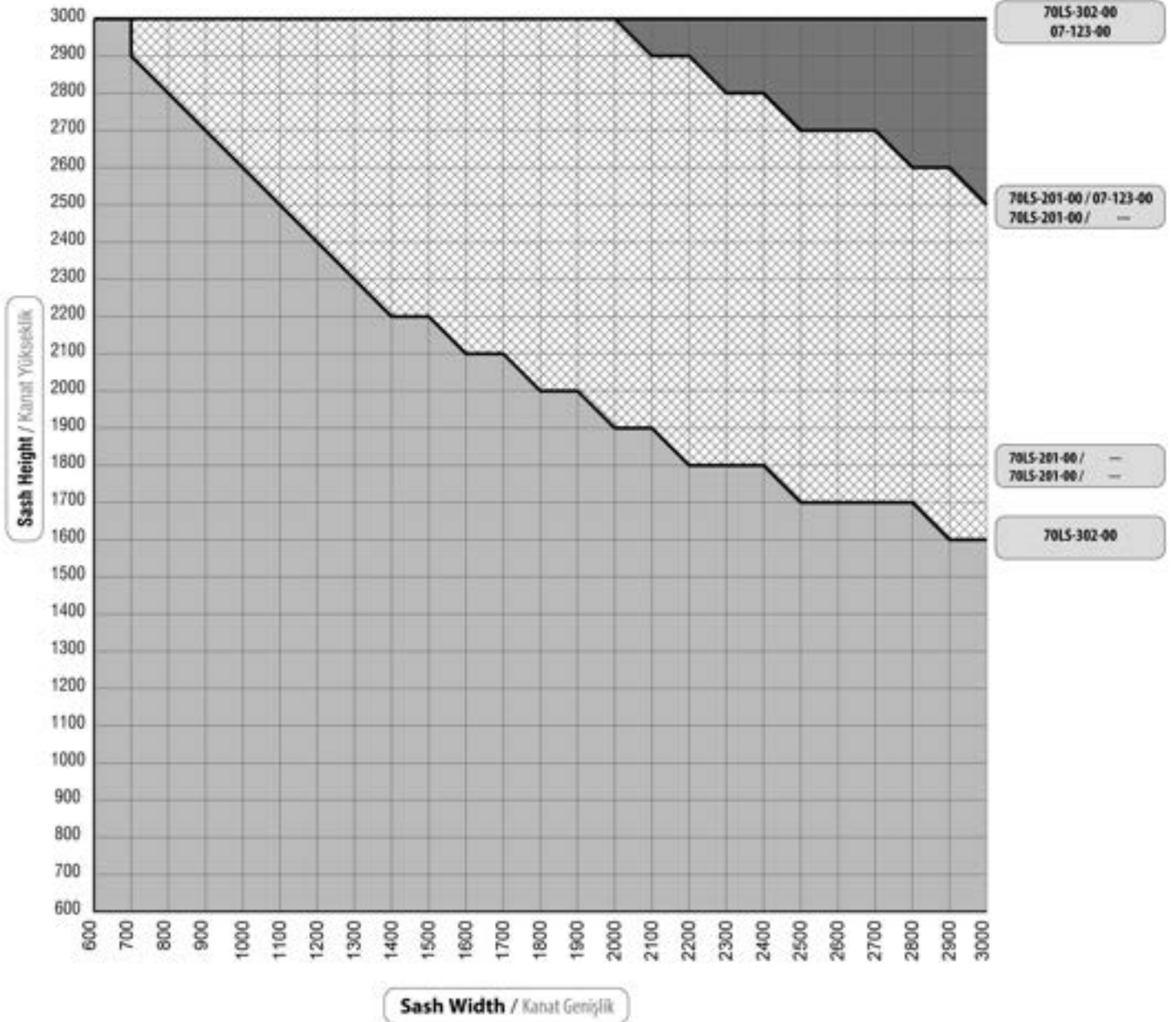

STATIC DIAGRAM / STATİK DİYAGRAM

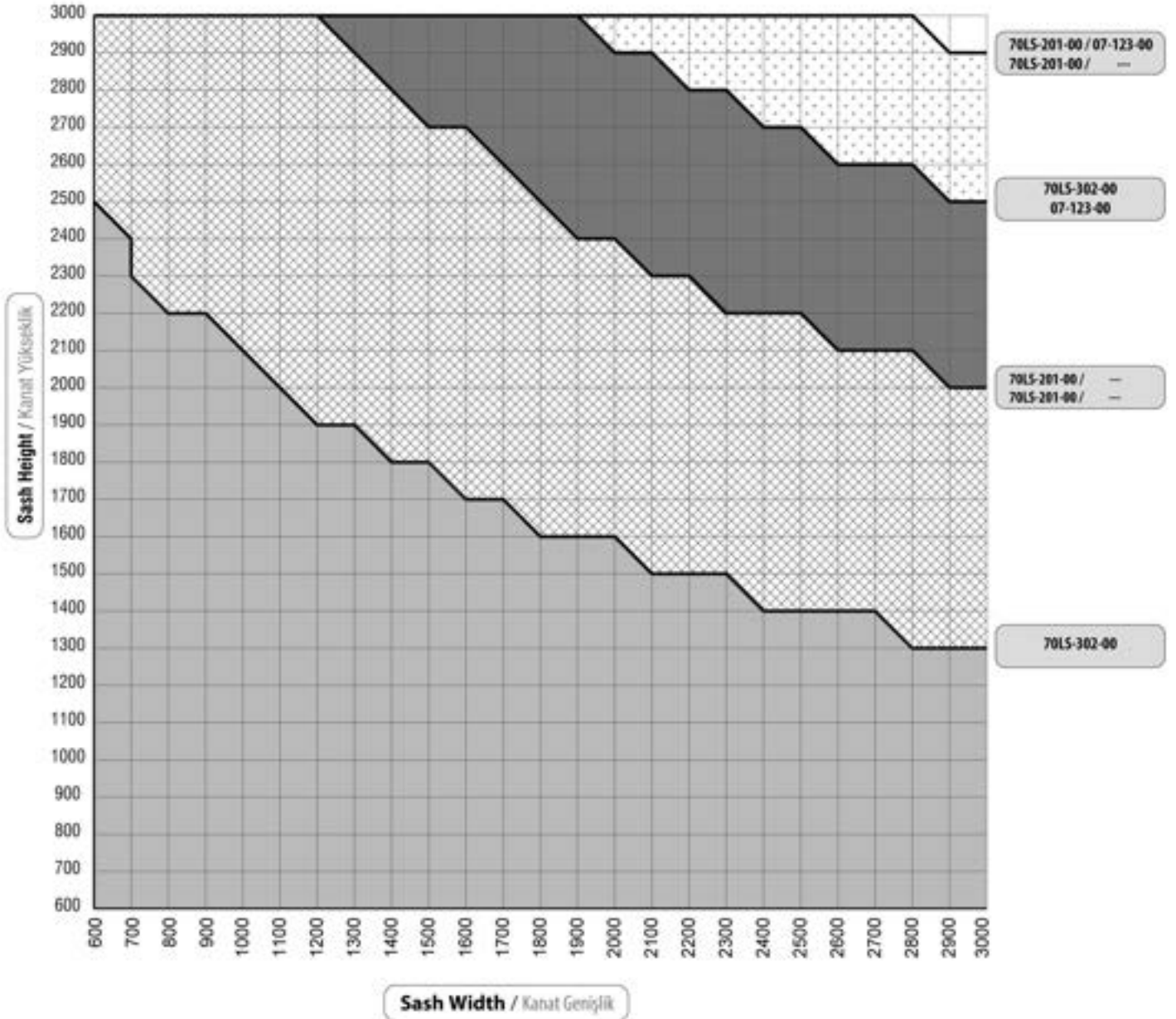
Building Height / Bina yüksekliği 8 - 20 Meter / Metre - 0,8 kN/m² - Sehim 20070LS-201-00 /
70LS-201-00 /70LS-201-00 / 07-123-00
70LS-201-00 /

70LS-302-00

70LS-302-00
07-123-00

07-123-00

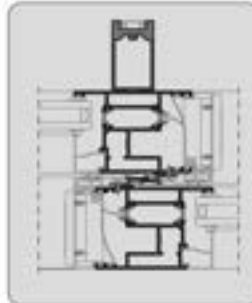
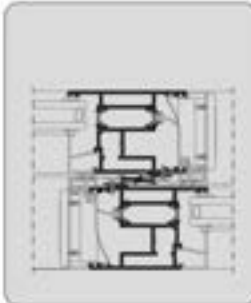

STATIC DIAGRAM / STATİK DİYAGRAM

Building Height / Bina yüksekliği 20 - 100 Meter / Metre - 1,1 kN/m² - Sehim 200

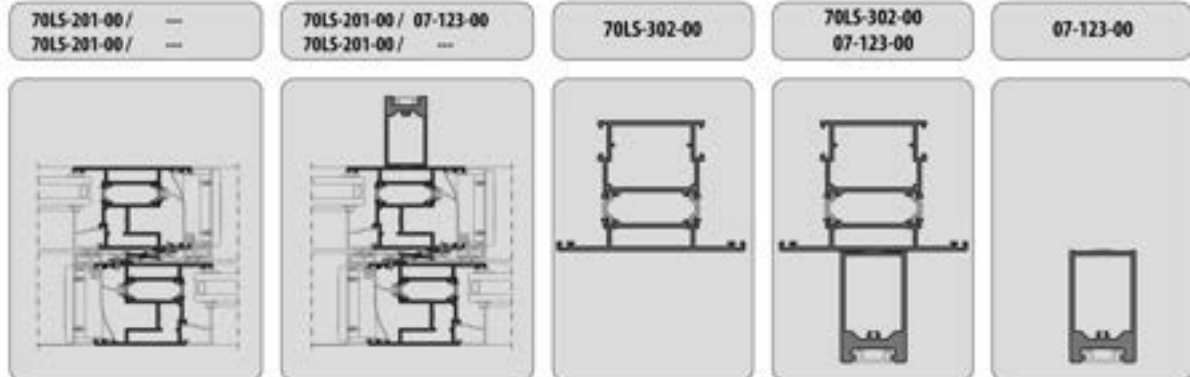
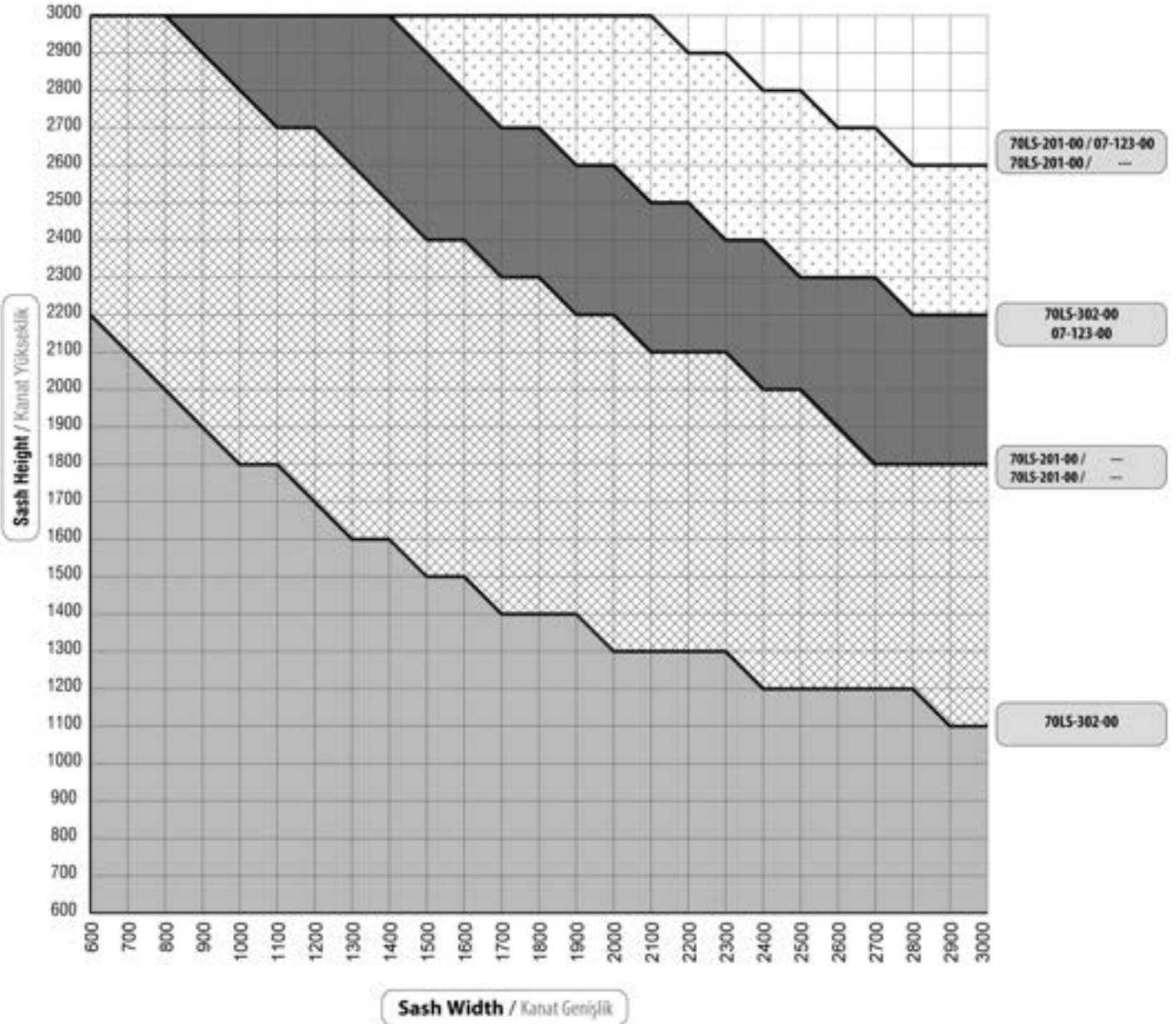

STATIC VALUES / STATİK DEĞERLER

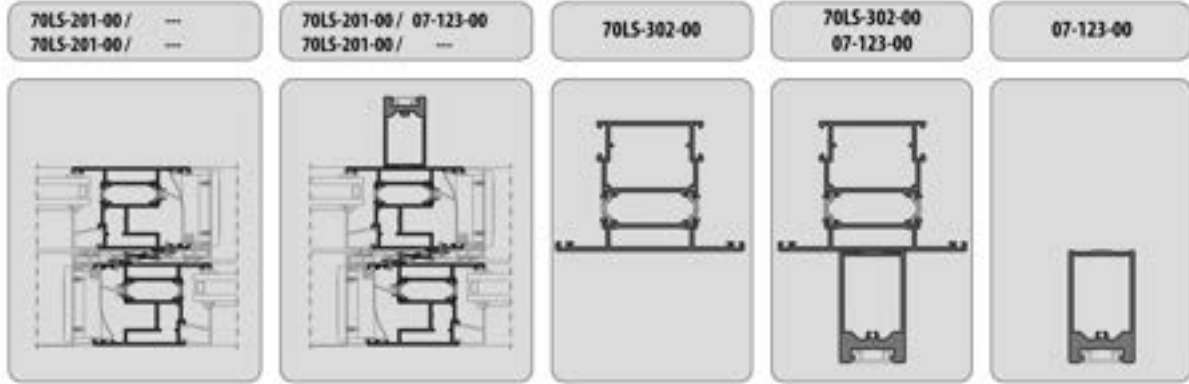

 Jx(cm⁴)

	70LS-201-00 / 70LS-201-00 /	70LS-201-00 / 07-123-00 70LS-201-00 /	70LS-302-00	70LS-302-00 07-123-00	07-123-00
600	35,24	103,94	13,27	81,63	22,45
700	37,73	108,32	14,23	84,24	
800	40,45	113,18	15,28	87,12	
900	43,37	118,45	16,39	90,23	
1000	46,43	124,06	17,55	93,53	
1100	49,59	129,95	18,73	96,97	
1200	52,81	136,06	19,91	100,51	
1300	56,05	142,31	21,10	104,11	
1400	59,29	148,67	22,26	107,75	
1500	62,49	155,07	23,40	111,39	
1600	65,63	161,48	24,51	115,00	
1700	68,70	167,85	25,58	118,57	
1800	71,69	174,16	26,61	122,07	
1900	74,57	180,36	27,60	125,49	
2000	77,36	186,44	28,54	128,82	
2100	80,03	192,39	29,44	132,05	
2200	82,59	198,17	30,29	135,17	
2300	85,05	203,79	31,10	138,18	
2400	87,37	209,24	31,86	141,08	
2500	89,60	214,50	32,58	143,86	
2600	91,71	219,58	33,26	146,53	
2700	93,72	224,47	33,91	149,08	
2800	95,63	229,18	34,52	151,52	
2900	97,44	233,71	35,09	153,85	
3000	99,16	238,05	35,63	156,08	

STATIC VALUES / STATİK DEĞERLER



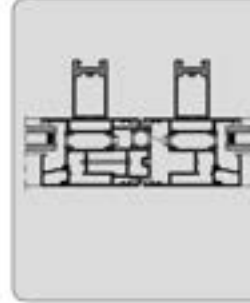







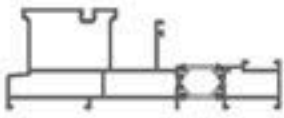

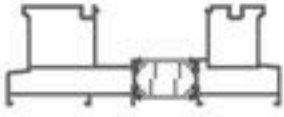

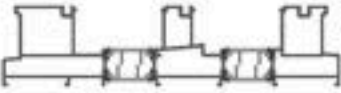

 70LS-201-00 / 70LS-503-00
51LS-201-00

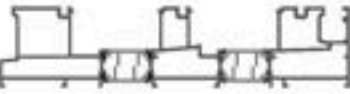

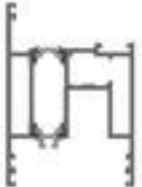

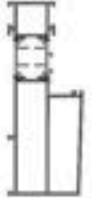











 70LS-201-00 / 07-123-00
70LS-503-00
51LS-201-00

 70LS-201-00 / 07-123-00
70LS-503-00
51LS-201-00 / 07-123-00

 $J_x(\text{cm}^4)$





PROFILE LENGTH / PROFİL BOYU (mm)	70LS-201-00 / 70LS-503-00 51LS-201-00	70LS-201-00 / 07-123-00 70LS-503-00 51LS-201-00	70LS-201-00 / 07-123-00 70LS-503-00 51LS-201-00 / 07-123-00
	600	36,08	93,15
700	38,62	97,24	155,87
800	41,41	101,79	162,16
900	44,41	106,71	169,02
1000	47,57	111,97	176,36
1100	50,84	117,48	184,11
1200	54,19	123,19	192,19
1300	57,59	129,05	200,52
1400	60,99	135,01	209,02
1500	64,37	141,00	217,64
1600	67,71	147,01	226,31
1700	70,98	152,98	234,98
1800	74,18	158,89	243,60
1900	77,28	164,71	252,13
2000	80,29	170,41	260,54
2100	83,18	175,99	268,79
2200	85,97	181,42	276,86
2300	88,65	186,69	284,74
2400	91,21	191,80	292,40
2500	93,65	196,74	299,84
2600	95,99	201,51	307,04
2700	98,22	206,11	314,01
2800	100,34	210,54	320,73
2900	102,36	214,79	327,22
3000	104,28	218,87	333,46

PROFILE INDEX |
PROFIL INDEKS

CODE / KOD	DRAWING / ÇİZİM	WEIGHT	CODE / KOD	DRAWING / ÇİZİM	WEIGHT
		AĞIRLIK Kg/m			AĞIRLIK Kg/m
70LS-101-00		2.577	07-123-00		1.591
70LS-102-00		2.746	07-124-00		0.129
70LS-112-00		3.062	70LS-401-00		0.708
70LS-103-00		4.177	70LS-402-00		0.762
70LS-113-00		4.493	70LS-421-00		0.490
70LS-201-00		2.417	70LS-501-00		0.487
74T-152-18		2.826	70LS-502-00		0.225
70LS-302-00		2.152	13-134-050R		0.118

CODE / KOD	DRAWING / ÇİZİM	WEIGHT	CODE / KOD	DRAWING / ÇİZİM	WEIGHT
		AĞIRLIK Kg/m			AĞIRLIK Kg/m
70LS-503-00		1.316	07-105-00		0.875
70LS-511-00		0.266	07-201-00		0.118
70LS-512-00		0.190	08-101-00		0.217
70LS-191-00		0.693	08-102-00		0.223
45T-251-00		1.103	08-103-00		0.237
45T-252-00		0.110	08-104-00		0.256
07-102-00		0.324	08-105-00		0.260
07-103-00		0.488	08-107-00		0.262

CODE / KOD	DRAWING / ÇİZİM	WEIGHT
		AĞIRLIK Kg/m
08-108-00		0.269
08-109-00		0.280
08-112-00		0.291
08-113-00		0.300
08-114-00		0.306
08-115-00		0.317
08-116-00		0.331
08-117-00		0.309

CODE / KOD	DRAWING / ÇİZİM	WEIGHT
		AĞIRLIK Kg/m
09-101-00		2.570
09-102-00		2.984
09-110-00		3.501
09-105-00		5.453

PROFILES
PROFILLER

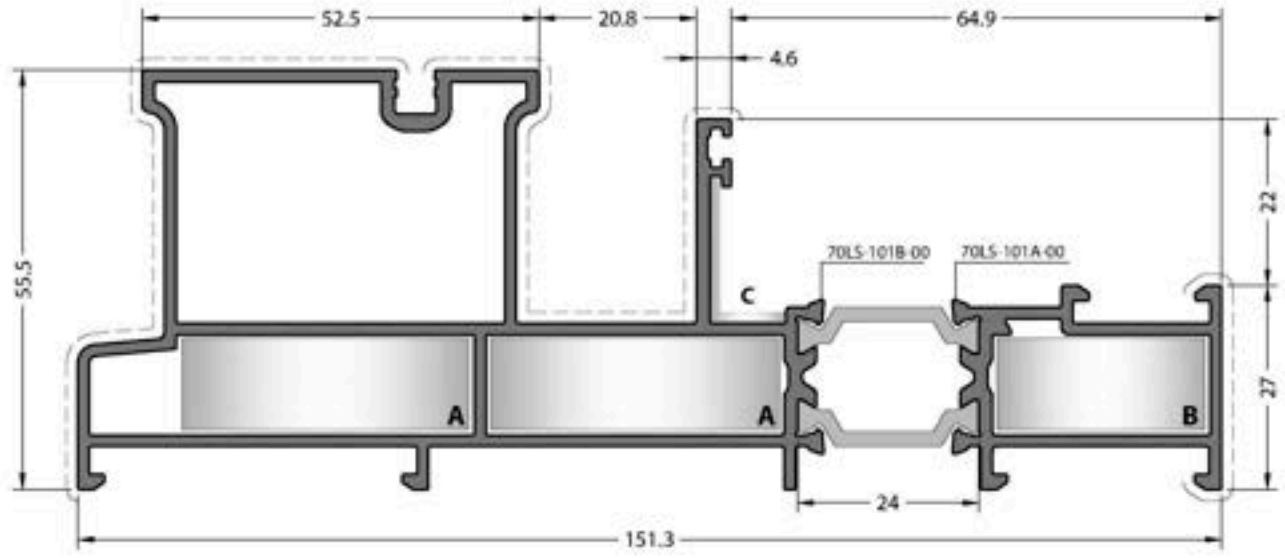

CODE / KOD
70LS-101-00

THEORETICAL WEIGHT kg/m
TEORİK AĞIRLIK kg/m
2.577

CORNER JOINTS
KÖŞE BAĞLANTILAR

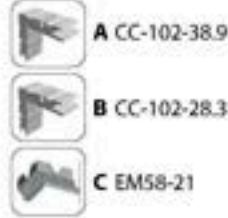

MECHANICAL CORNER JOINTS
MEKANİK KÖŞE BAĞLANTILAR

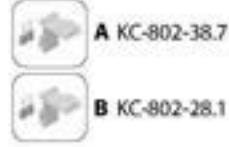

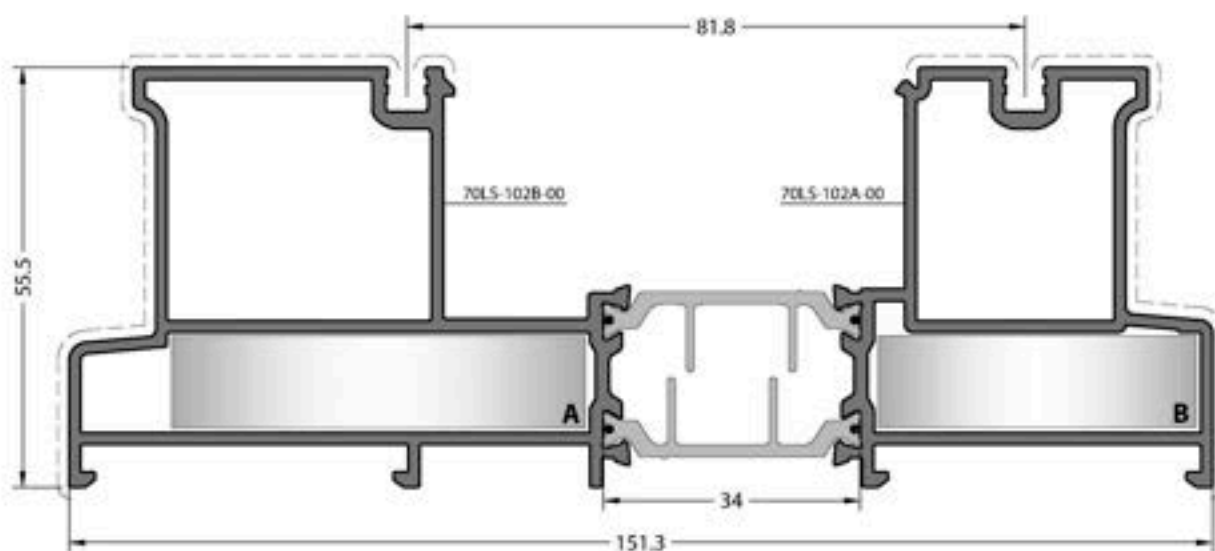

CODE / KOD
70LS-102-00

THEORETICAL
WEIGHT kg/m
TEORİK AĞIRLIK kg/m
2.746

CORNER JOINTS
KÖŞE BAĞLANTILAR

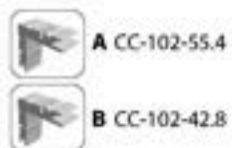

MECHANICAL
CORNER JOINTS
MEKANİK KÖŞE BAĞLANTILAR

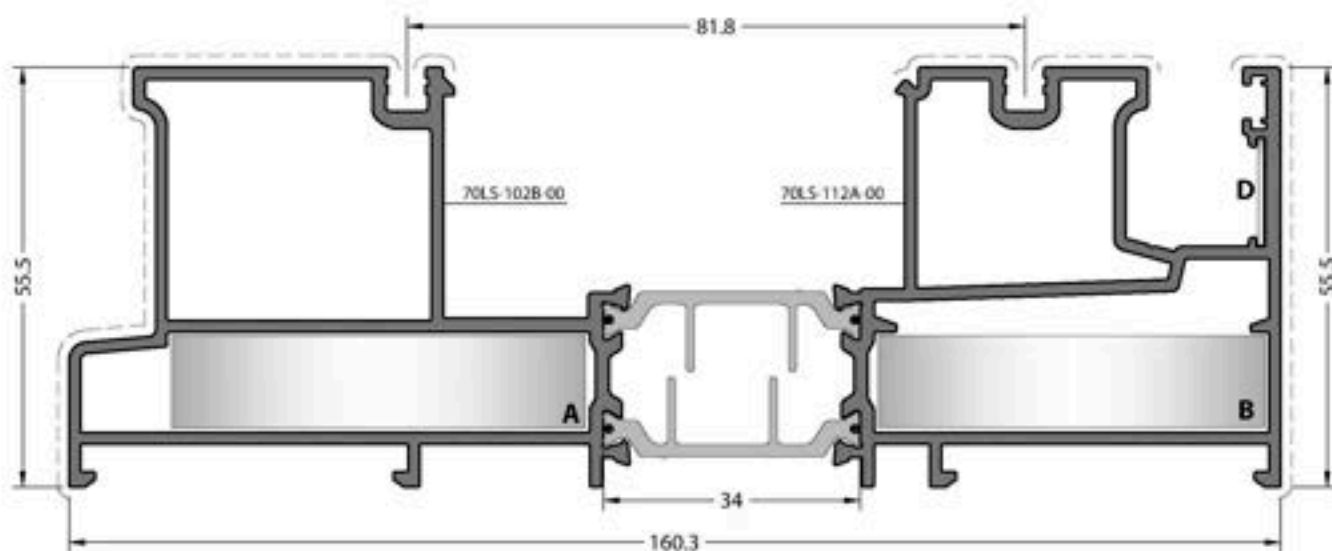
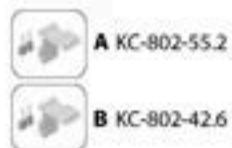

CODE / KOD
70LS-112-00

THEORETICAL
WEIGHT kg/m
TEORİK AĞIRLIK kg/m
3.062

CORNER JOINTS
KÖŞE BAĞLANTILAR

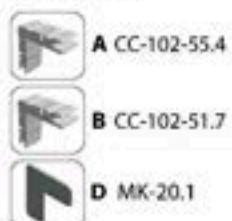

MECHANICAL
CORNER JOINTS
MEKANİK KÖŞE BAĞLANTILAR

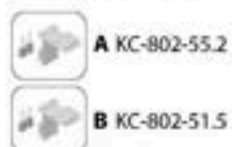

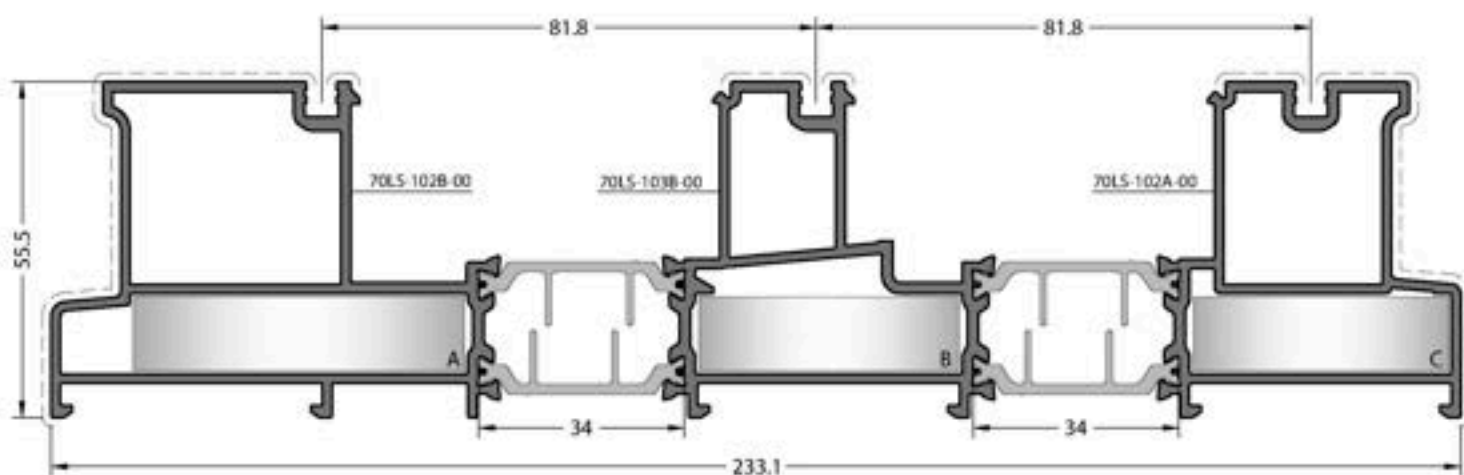

No Scaled / Ölçeksiz

CODE / KOD
70LS-103-00

THEORETICAL
WEIGHT kg/m
TEORİK AĞIRLIK kg/m
4.177

CORNER JOINTS
KÖŞE BAĞLANTILAR



A CC-102-55.4



B CC-102-43.7



C CC-102-42.8

MECHANICAL
CORNER JOINTS
MEKANİK KÖŞE BAĞLANTILAR



A KC-802-55.2



B KC-802-43.5



C KC-802-42.6

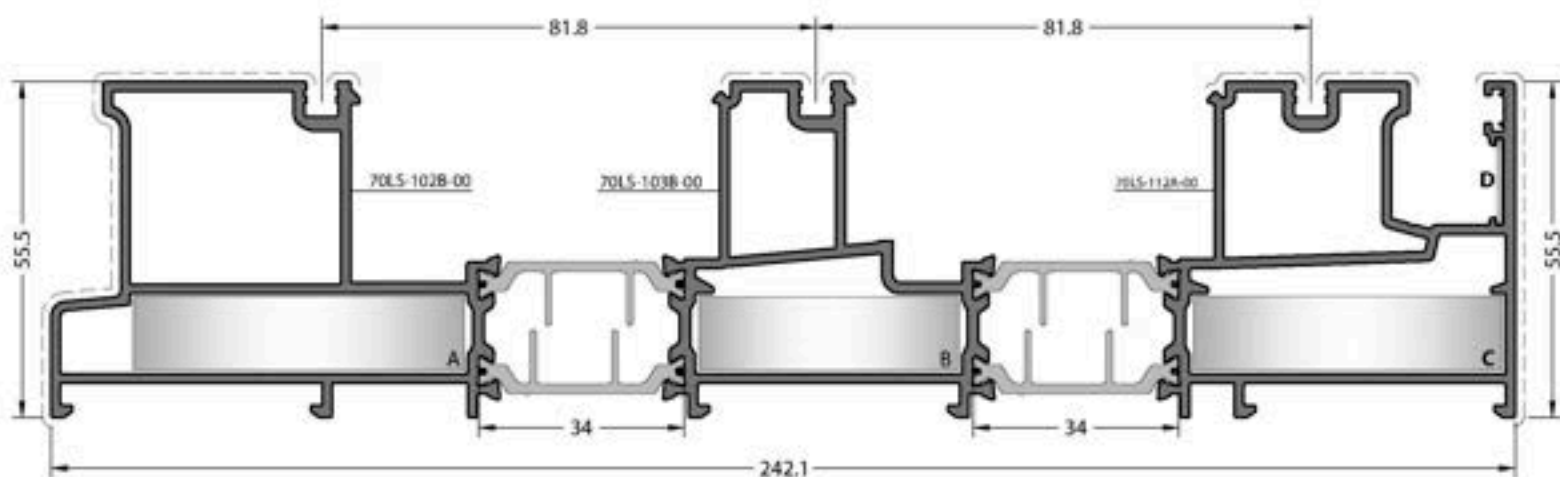

No Scaled / Ölçeksiz

CODE / KOD
70LS-113-00

THEORETICAL
WEIGHT kg/m
TEORİK AĞIRLIK kg/m
4.493

CORNER JOINTS
KÖŞE BAĞLANTILAR



A CC-102-55.4



B CC-102-43.7



C CC-102-51.7



D MK-20.1

MECHANICAL
CORNER JOINTS
MEKANİK KÖŞE BAĞLANTILAR



A KC-802-55.2



B KC-802-43.5



C KC-802-51.5

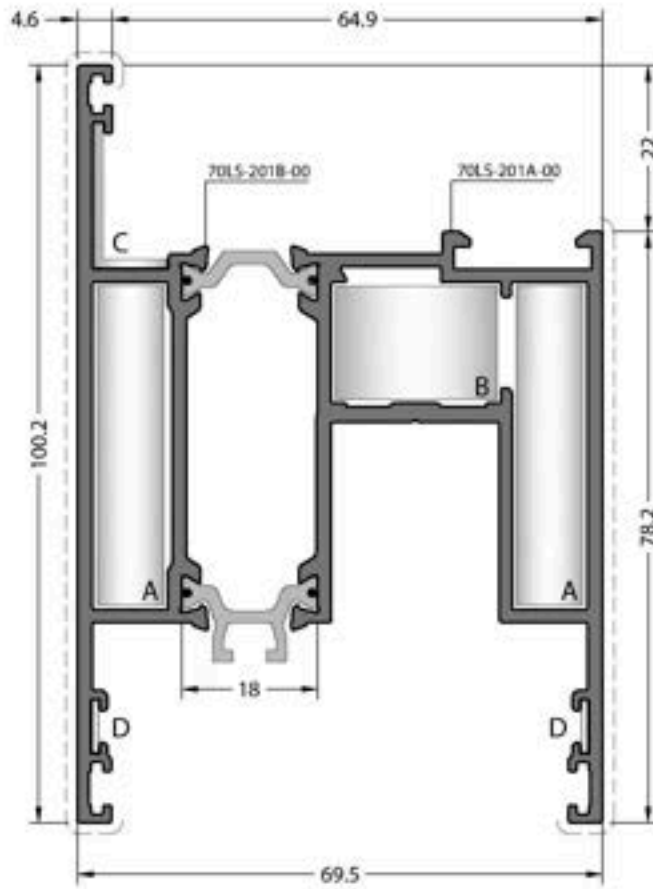

CODE / KOD
70LS-201-00

THEORETICAL WEIGHT kg/m
TEORİK AĞIRLIK kg/m
2.417

CORNER JOINTS
KÖŞE BAĞLANTILARI



A CC-105-09.6



B CC-110-22.0



C EM58-21



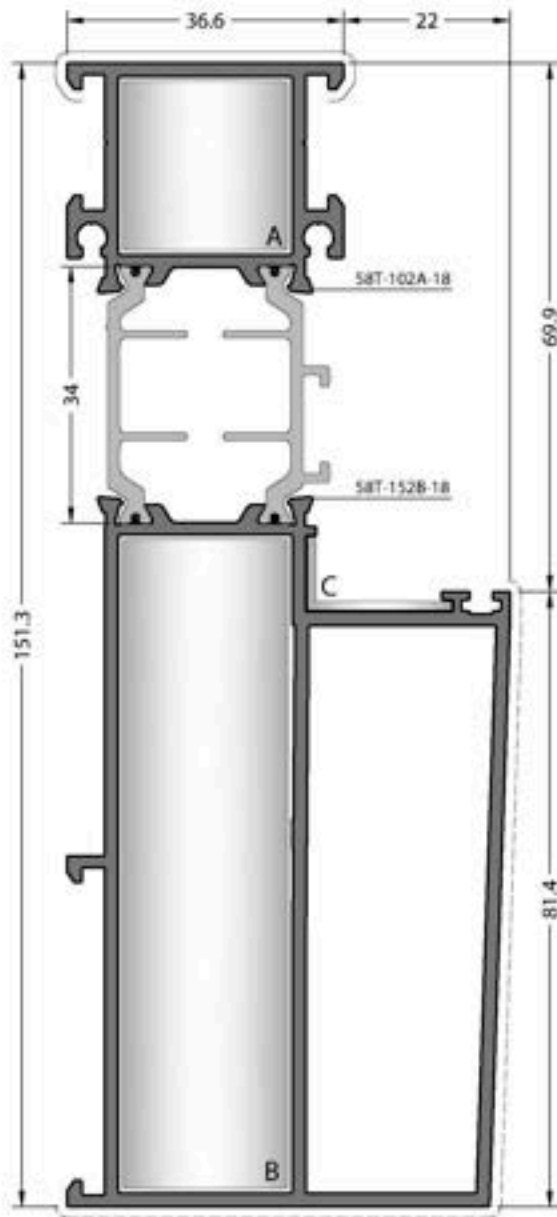

D LC-107



CODE / KOD
74T-152-18

THEORETICAL WEIGHT kg/m
 TEORİK AĞIRLIK kg/m
2.826

CORNER JOINTS
 KÖŞE BAĞLANTILAR

-  **A** CC-103-23.0
-  **B** CC-103-86.5
-  **C** EM58-21

PROFILES / PROFİLLER

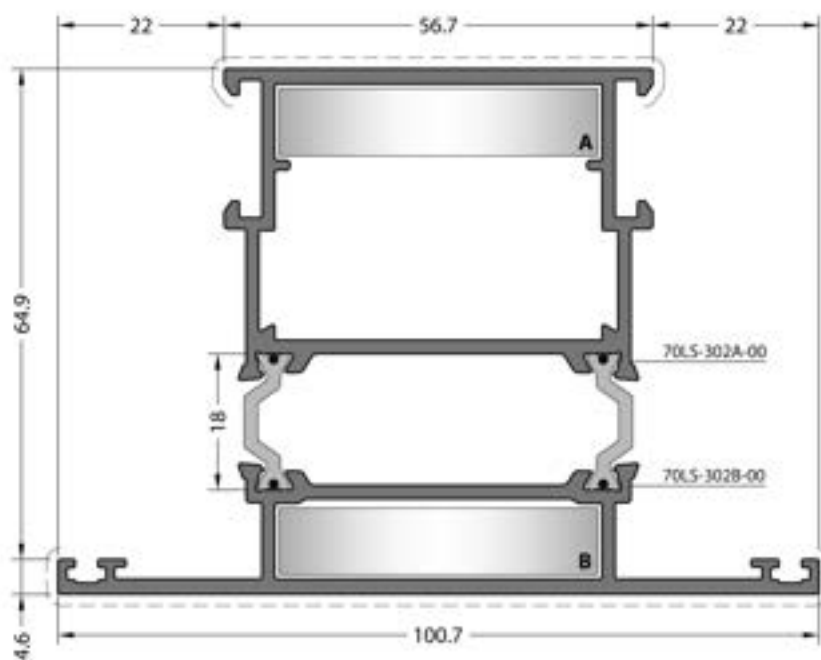

CODE / KOD
70LS-302-00

THEORETICAL
WEIGHT kg/m
TEORİK AĞIRLIK kg/m
2.152

JOINTS
BAĞLANTILAR



A CC70-901-42.8



B CC70-902-42.8

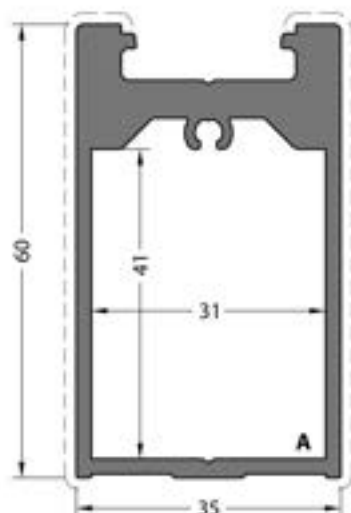

CODE / KOD
07-123-00

THEORETICAL
WEIGHT kg/m
TEORİK AĞIRLIK kg/m
1.591

ACCESSORY
AKSESUAR



A CA07-123

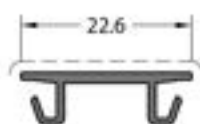

CODE / KOD
07-124-00

THEORETICAL
WEIGHT kg/m
TEORİK AĞIRLIK kg/m
0.129

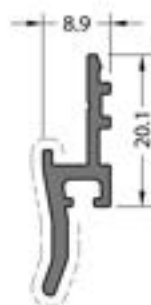

12 Micron Matte Black Anodized.
12 Mikron Mat Siyah Elektol.

CODE / KOD
70LS-502-00

THEORETICAL
WEIGHT kg/m
TEORİK AĞIRLIK kg/m
0.225

Application Details / Uygulama Detay

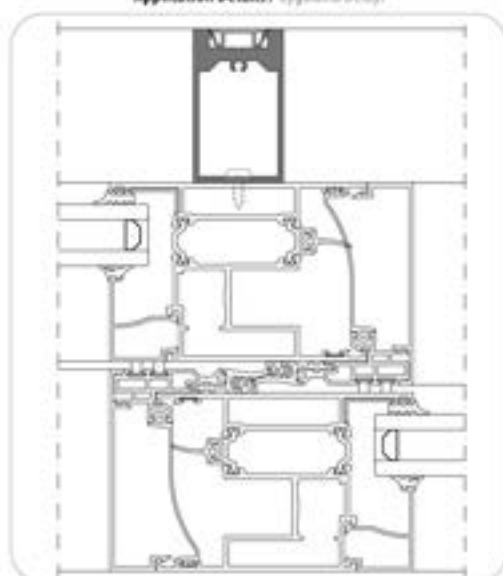

Application Details / Uygulama Detay

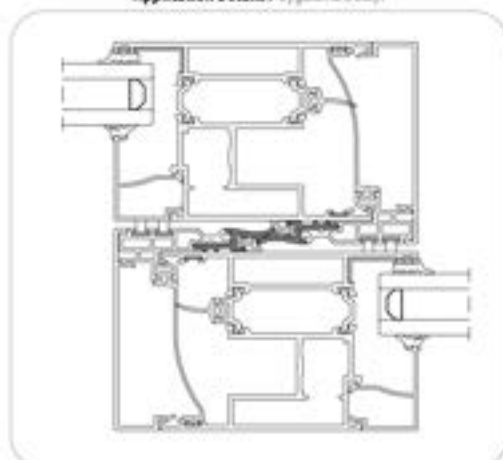



CODE / KOD
70LS-501-00
THEORETICAL WEIGHT kg/m
TEORİK AĞIRLIK kg/m
0.487

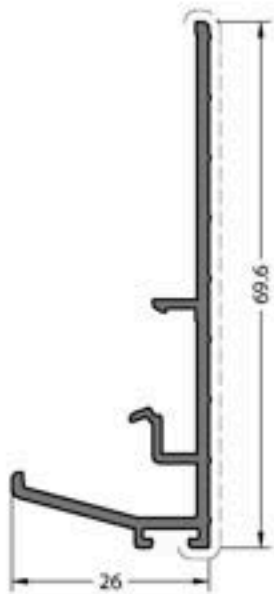

CODE / KOD
70LS-421-00
THEORETICAL WEIGHT kg/m
TEORİK AĞIRLIK kg/m
0.490

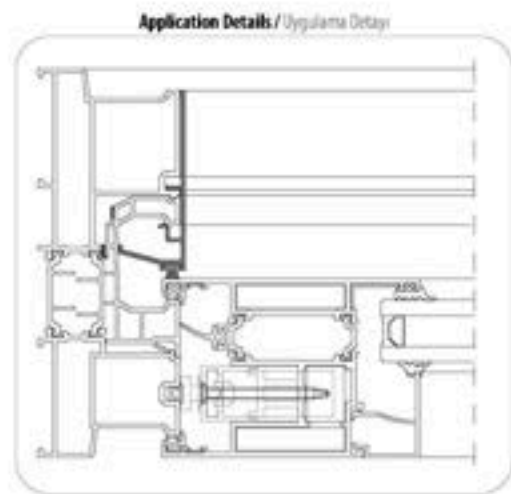

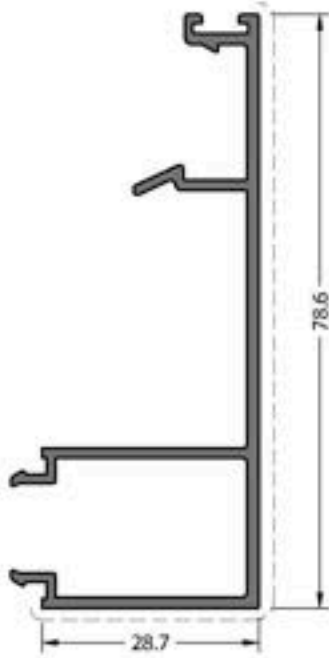

CODE / KOD
70LS-401-00

THEORETICAL WEIGHT kg/m
TEORİK AĞIRLIK kg/m
0.708

Application Details / Uygulama Detayı

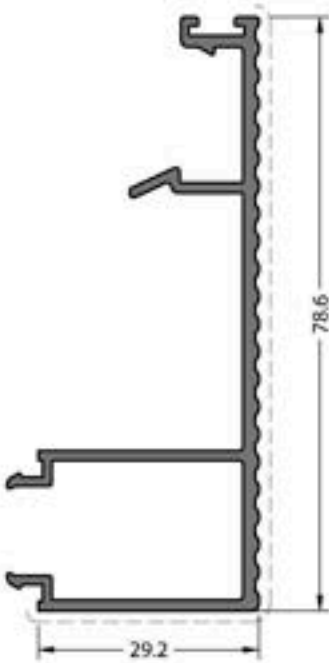

CODE / KOD
70LS-402-00

THEORETICAL WEIGHT kg/m
TEORİK AĞIRLIK kg/m
0.762

Application Details / Uygulama Detayı

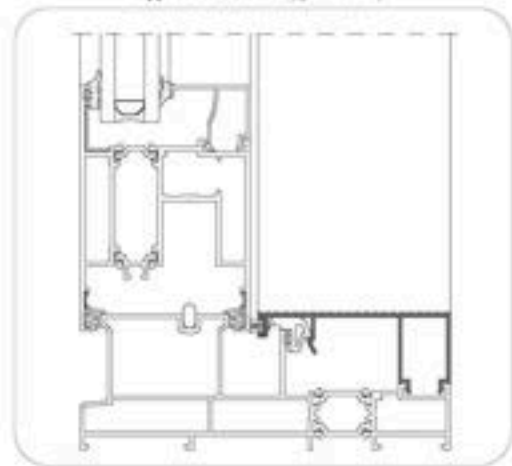

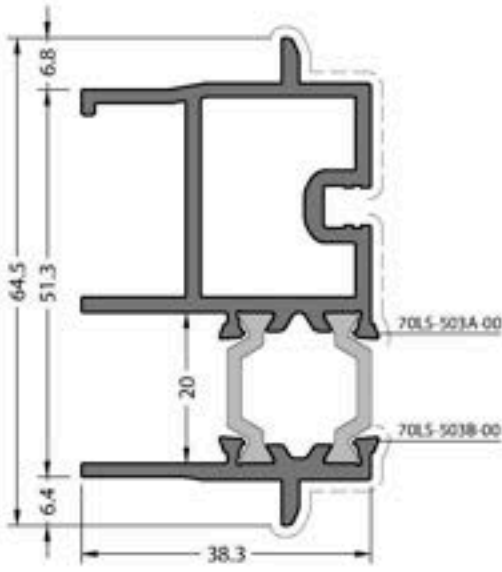

CODE / KOD
70LS-503-00

THEORETICAL
WEIGHT kg/m
TEORİK AĞIRLIK kg/m
1.316

Application Details / Uygulama Detayı

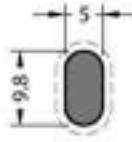
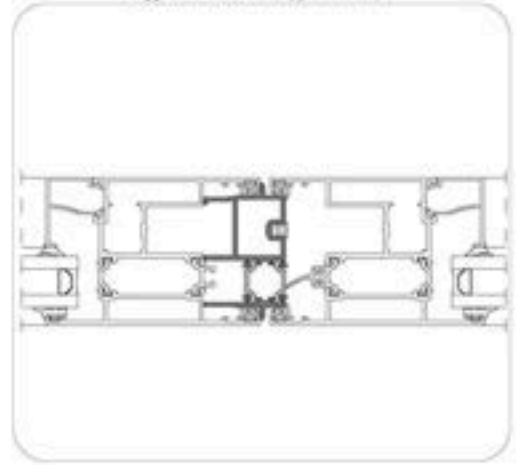

20 Micron Anodized.
20 Mikron Elektal.

CODE / KOD
13-134-050R

THEORETICAL
WEIGHT kg/m
TEORİK AĞIRLIK kg/m
0.118

Application Details / Uygulama Detayı

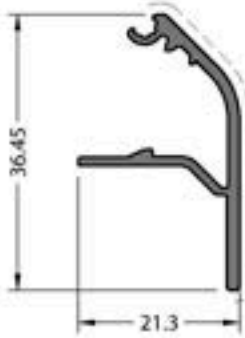
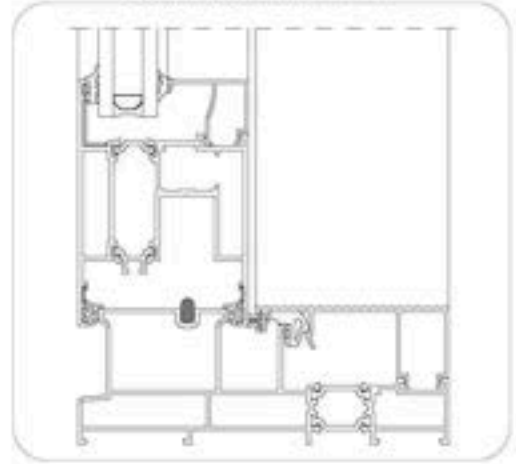

CODE / KOD
70LS-511-00

THEORETICAL
WEIGHT kg/m
TEORİK AĞIRLIK kg/m
0.266

END CAP SET
YAN KAPAK TAKIMI



Application Details / Uygulama Detayı

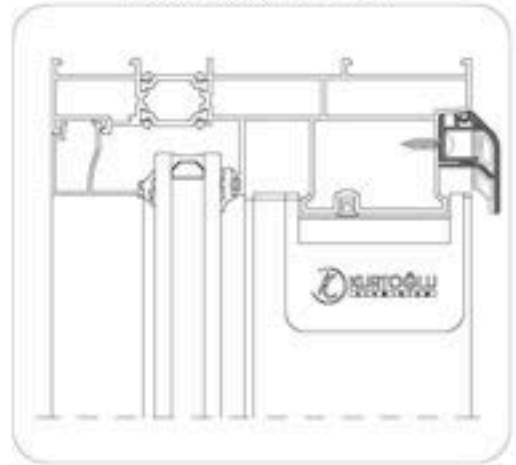

Mil Finish / Pürüz
No visible surface. / Görünen yüzeyi yoktur.

CODE / KOD
70LS-512-00

THEORETICAL
WEIGHT kg/m
TEORİK AĞIRLIK kg/m
0.190

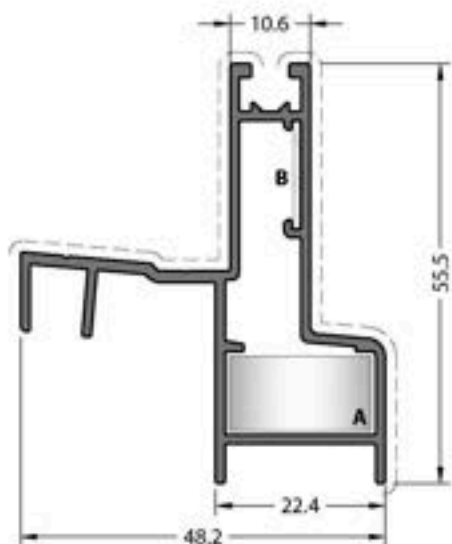

CODE / KOD
70LS-191-00

THEORETICAL WEIGHT kg/m
TEORİK AĞIRLIK kg/m

0.693

JOINTS
BAĞLANTILAR



A CC-101-19.5



D MK-20.1

DIE-CAST CORNER JOINT
PİMLİ BAĞLANTI



A LC-11.20

Application Details / Uygulama Detay

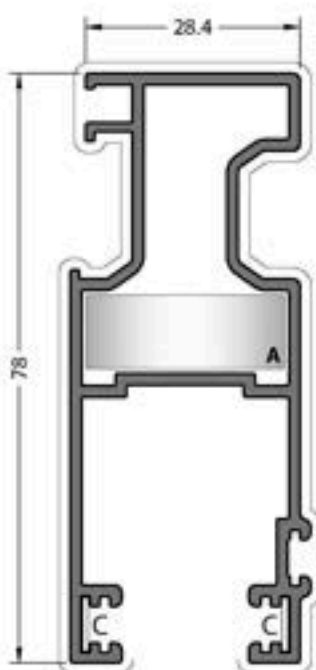
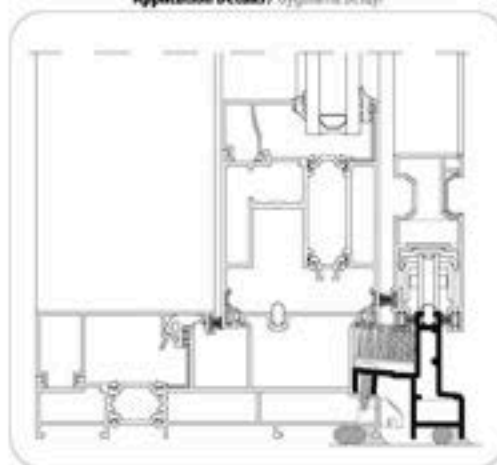

CODE / KOD
45T-251-00

THEORETICAL WEIGHT kg/m
TEORİK AĞIRLIK kg/m

1.103

JOINTS
BAĞLANTILAR



A LC-11.27



C LC-10.7

Application Details / Uygulama Detay

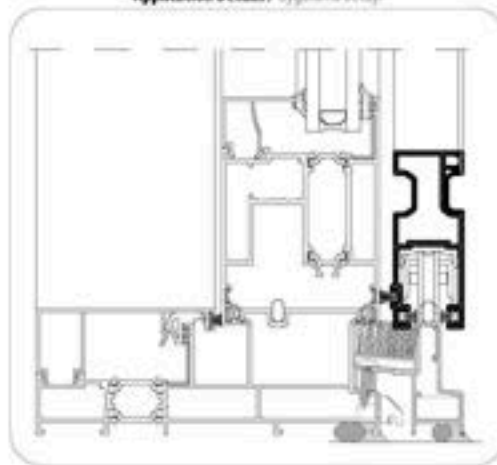

CODE / KOD
45T-252-00

THEORETICAL WEIGHT kg/m
TEORİK AĞIRLIK kg/m

0.110

Application Details / Uygulama Detay

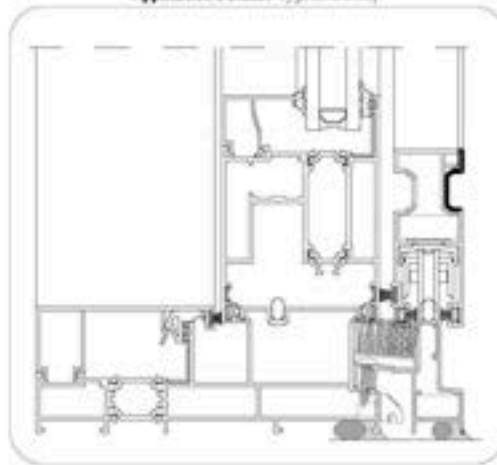

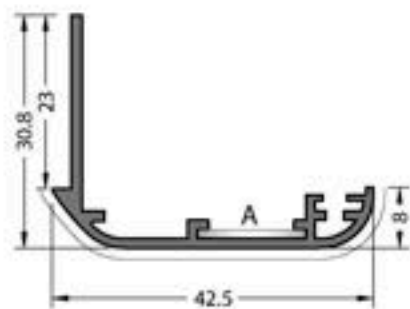

CODE / KOD
07-102-00

CORNER JOINT
KÖŞE BAĞLANTI



A MK-20.1

THEORETICAL
WEIGHT kg/m
TEORİK AĞIRLIK kg/m
0.324

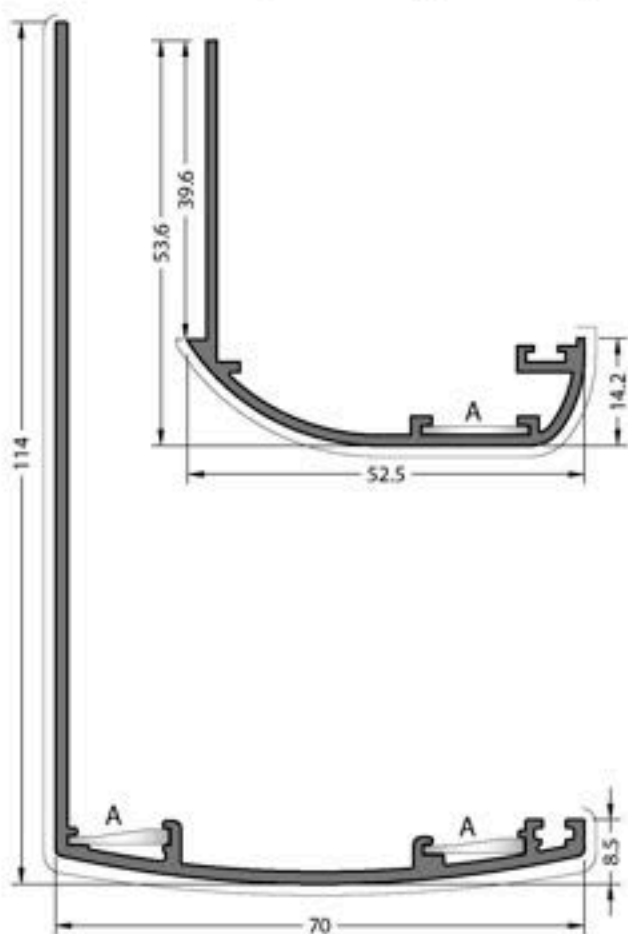

CODE / KOD
07-103-00

CORNER JOINT
KÖŞE BAĞLANTI



A MK-20.1

THEORETICAL
WEIGHT kg/m
TEORİK AĞIRLIK kg/m
0.488

CODE / KOD
07-105-00

CORNER JOINT
KÖŞE BAĞLANTI



A LC-122

THEORETICAL
WEIGHT kg/m
TEORİK AĞIRLIK kg/m
0.875

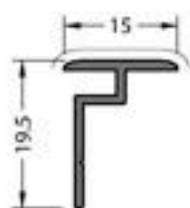

CODE / KOD
07-201-00

THEORETICAL
WEIGHT kg/m
TEORİK AĞIRLIK kg/m
0.118



CODE / KOD
08-101-00

THEORETICAL
WEIGHT kg/m
TEORİK AĞIRLIK kg/m
0.218



CODE / KOD
08-102-00

THEORETICAL
WEIGHT kg/m
TEORİK AĞIRLIK kg/m
0.223



CODE / KOD
08-103-00

THEORETICAL
WEIGHT kg/m
TEORİK AĞIRLIK kg/m
0.237



CODE / KOD
08-104-00

THEORETICAL
WEIGHT kg/m
TEORİK AĞIRLIK kg/m
0.256



CODE / KOD
08-105-00

THEORETICAL
WEIGHT kg/m
TEORİK AĞIRLIK kg/m
0.260



CODE / KOD
08-107-00

THEORETICAL
WEIGHT kg/m
TEORİK AĞIRLIK kg/m
0.262



CODE / KOD
08-108-00

THEORETICAL
WEIGHT kg/m
TEORİK AĞIRLIK kg/m
0.269



CODE / KOD
08-109-00

THEORETICAL
WEIGHT kg/m
TEORİK AĞIRLIK kg/m
0.280



CODE / KOD
08-112-00

THEORETICAL
WEIGHT kg/m
TEORİK AĞIRLIK kg/m
0.291



CODE / KOD
08-113-00

THEORETICAL
WEIGHT kg/m
TEORİK AĞIRLIK kg/m
0.300



CODE / KOD
08-114-00

THEORETICAL
WEIGHT kg/m
TEORİK AĞIRLIK kg/m
0.306



CODE / KOD
08-117-00

THEORETICAL
WEIGHT kg/m
TEORİK AĞIRLIK kg/m
0.309

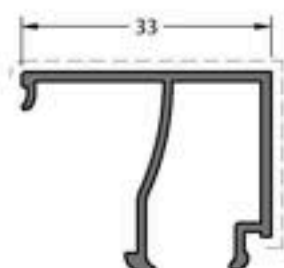

CODE / KOD
08-115-00

THEORETICAL
WEIGHT kg/m
TEORİK AĞIRLIK kg/m
0.317



CODE / KOD
08-116-00

THEORETICAL
WEIGHT kg/m
TEORİK AĞIRLIK kg/m
0.331



Mill Finish / Pres
No visible surface. / Görünmez yüzeyi yoktur.

CODE / KOD
09-101-00

THEORETICAL
WEIGHT kg/m
TEORİK AĞIRLIK kg/m
2.561

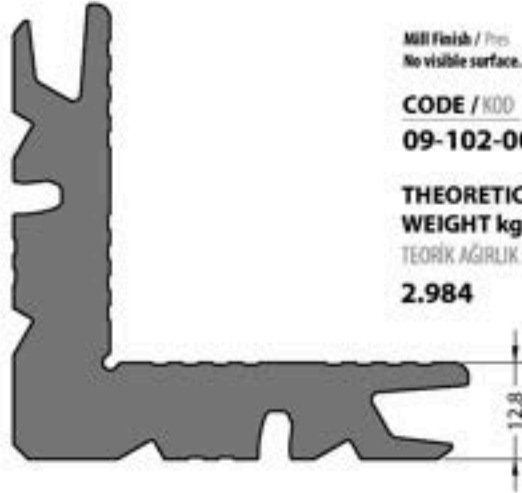

Mill Finish / Pres
No visible surface. / Görünmez yüzeyi yoktur.

CODE / KOD
09-102-00

THEORETICAL
WEIGHT kg/m
TEORİK AĞIRLIK kg/m
2.984



Mill Finish / Pres
No visible surface. / Görünmez yüzeyi yoktur.

CODE / KOD
09-110-00

THEORETICAL
WEIGHT kg/m
TEORİK AĞIRLIK kg/m
3.501

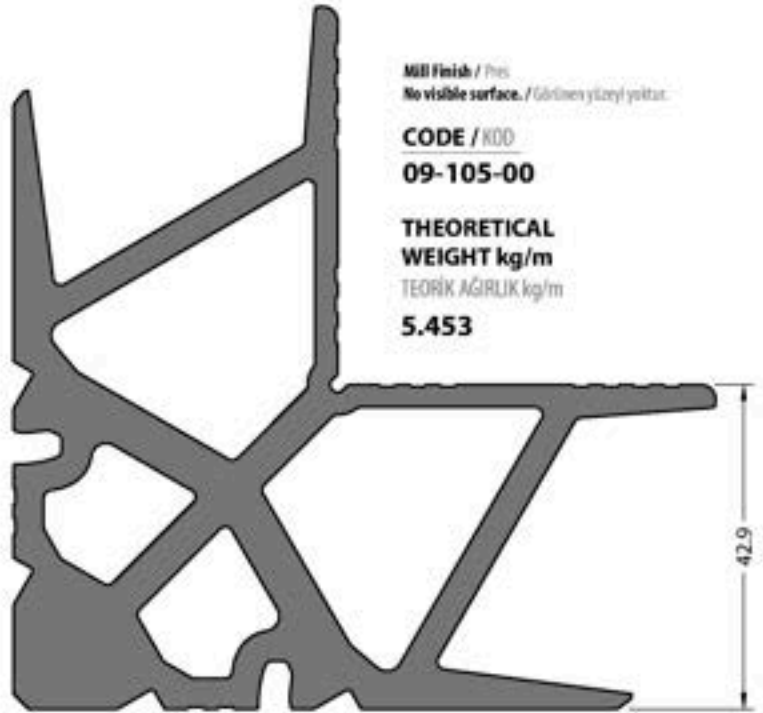

Mill Finish / Pres
No visible surface. / Görünmez yüzeyi yoktur.

CODE / KOD
09-105-00

THEORETICAL
WEIGHT kg/m
TEORİK AĞIRLIK kg/m
5.453

DETAILS
DETAYLAR

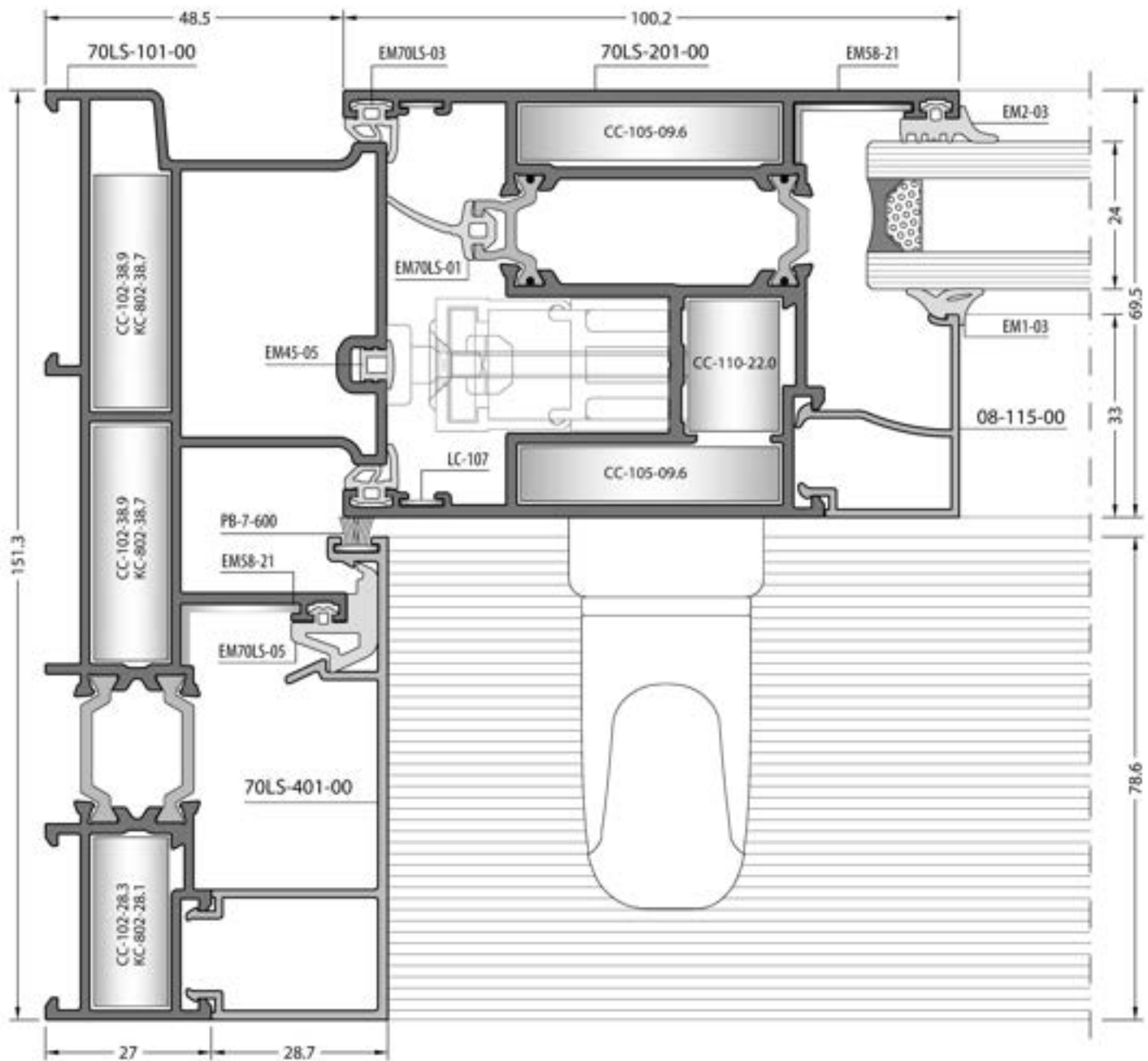
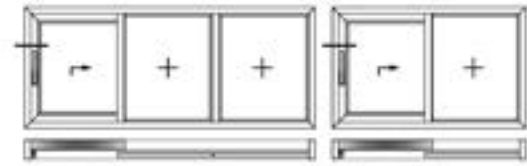

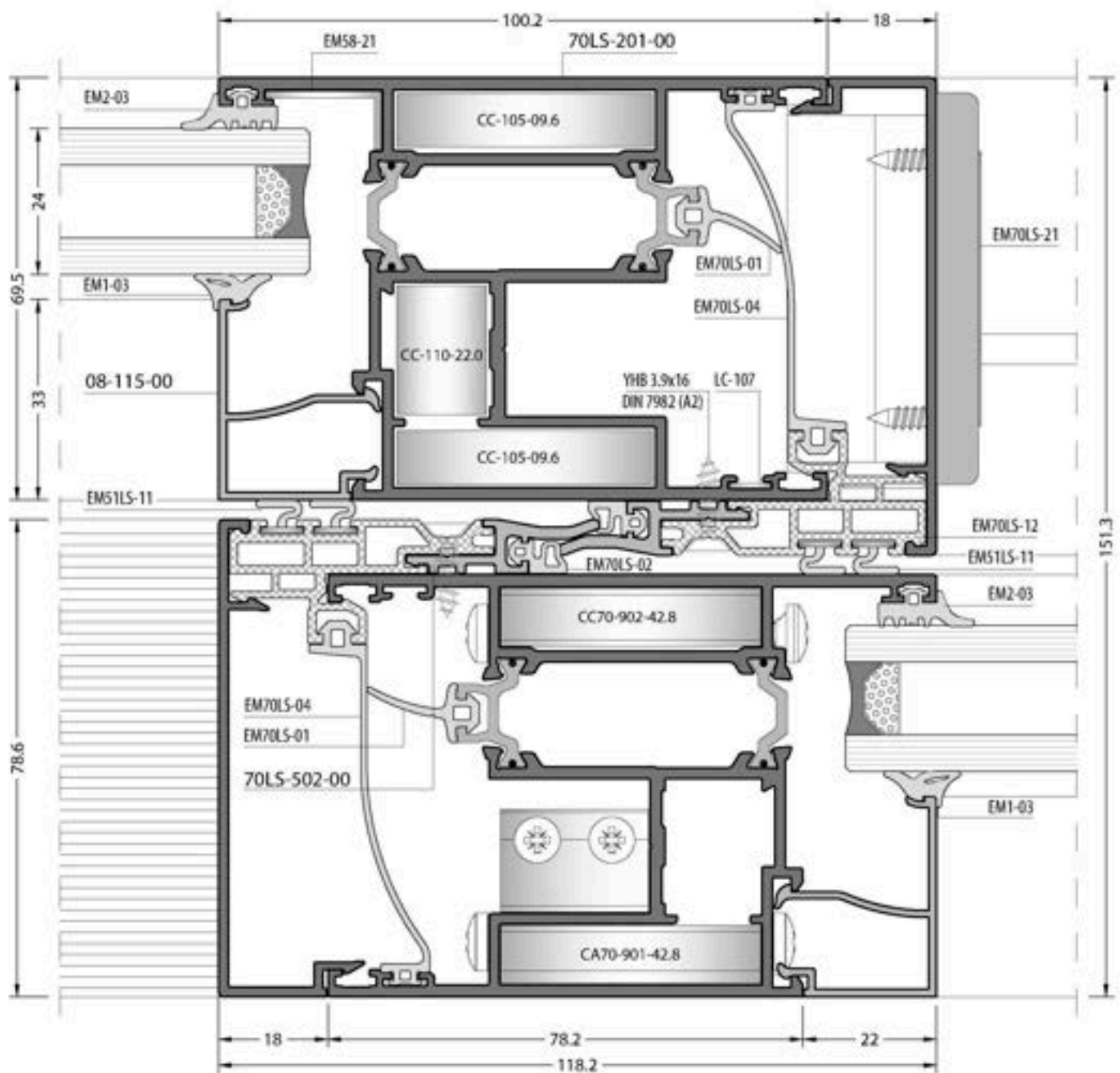
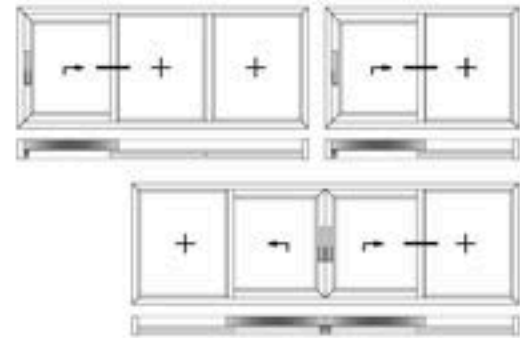

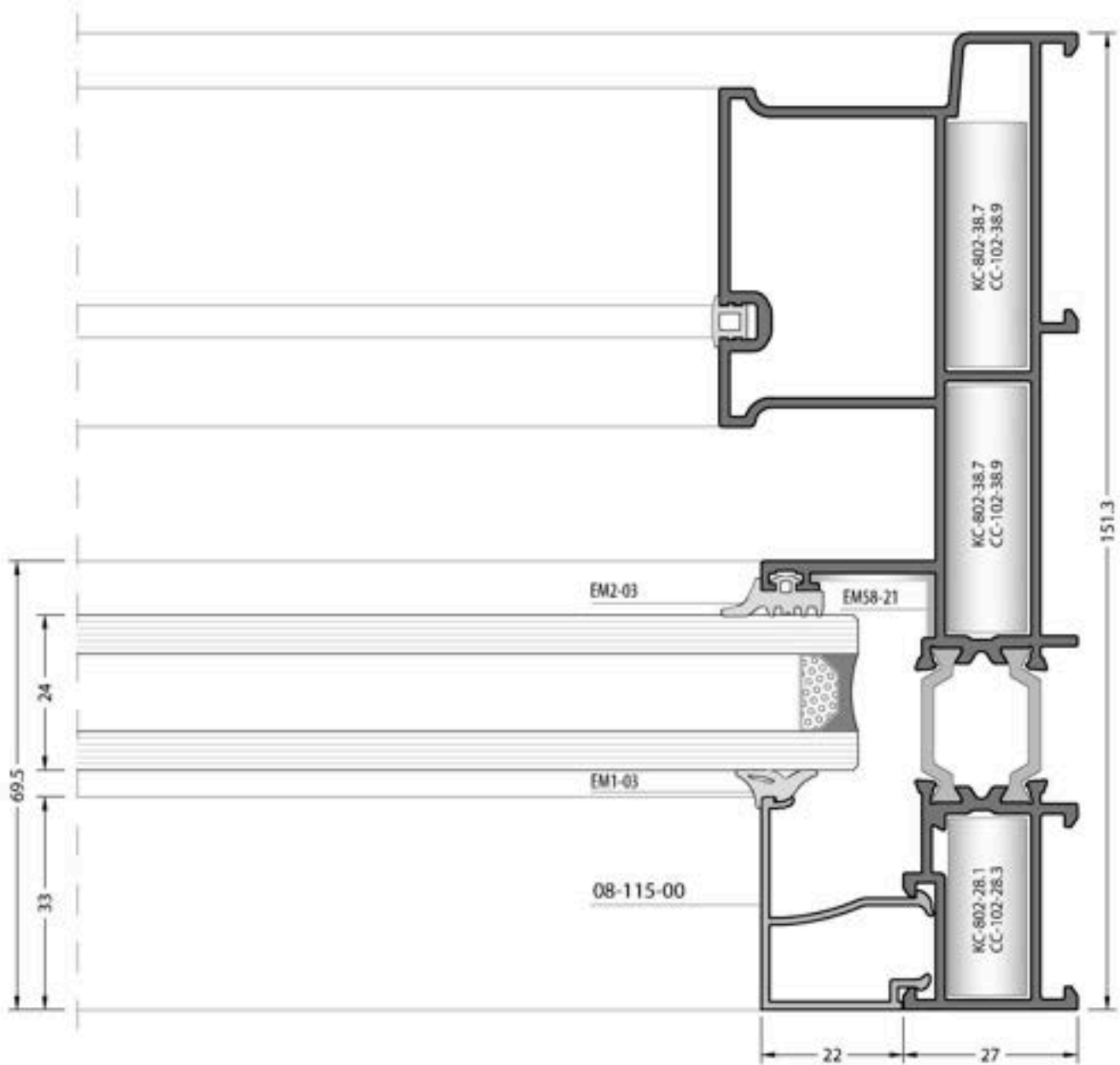
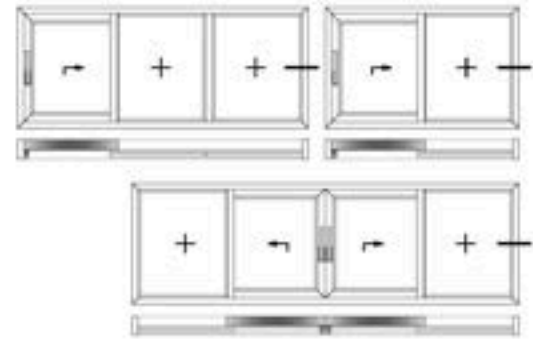

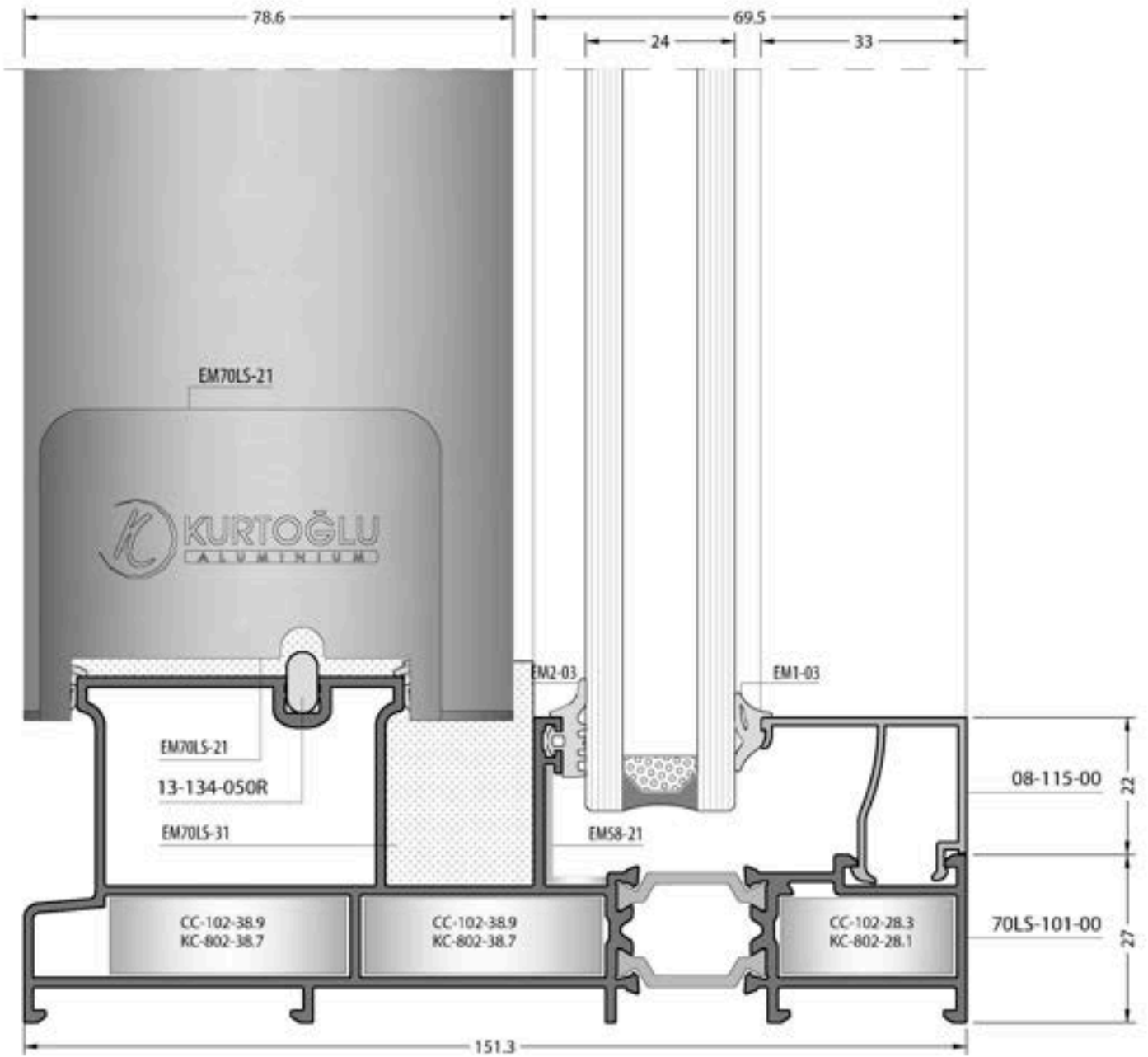
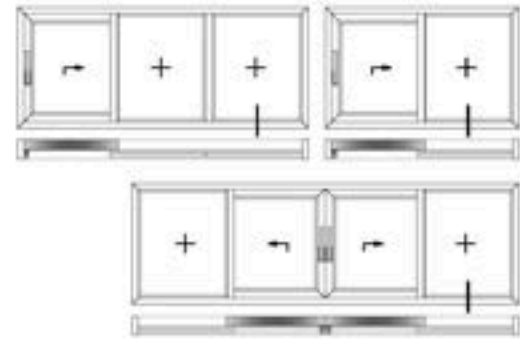

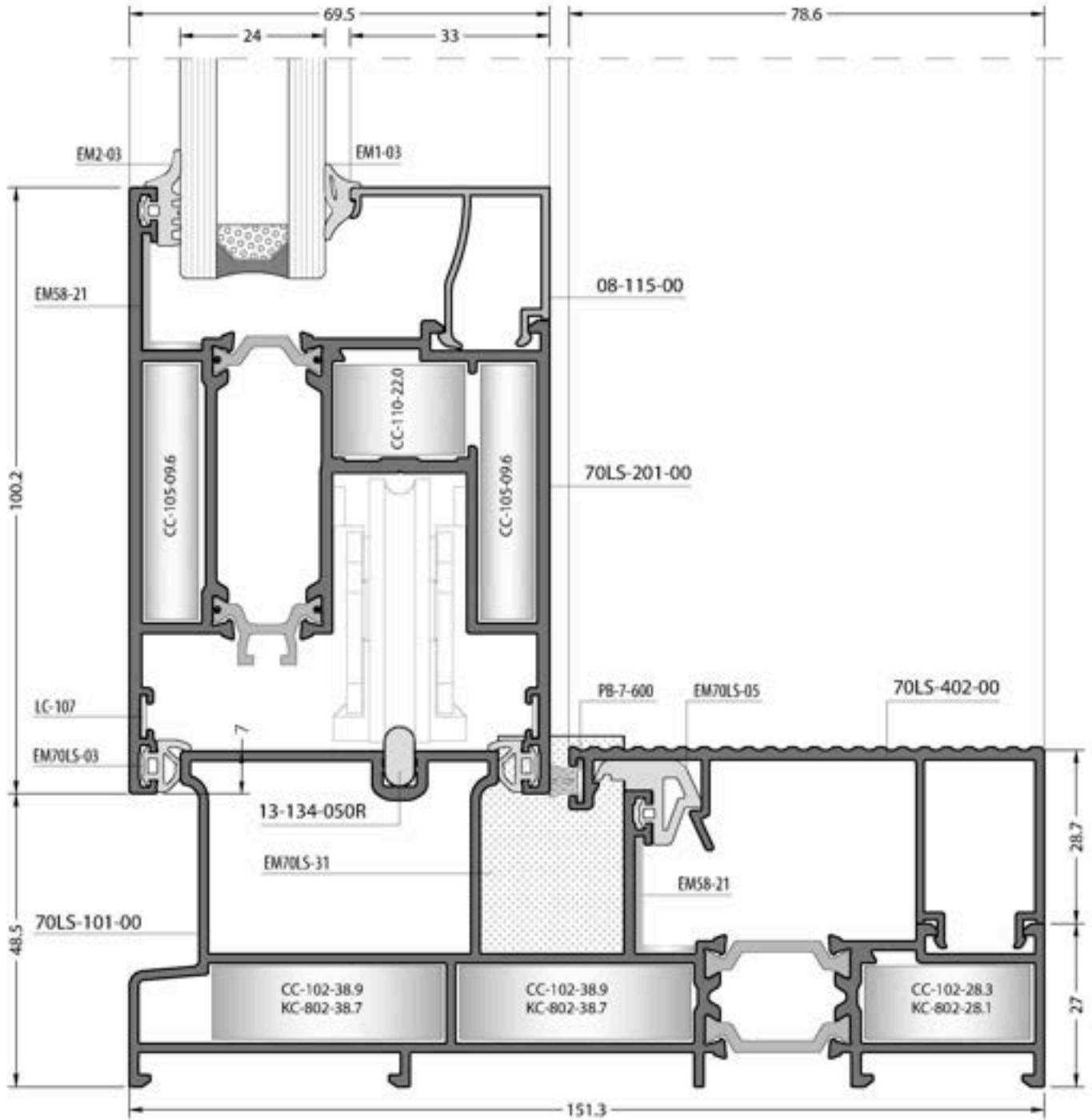
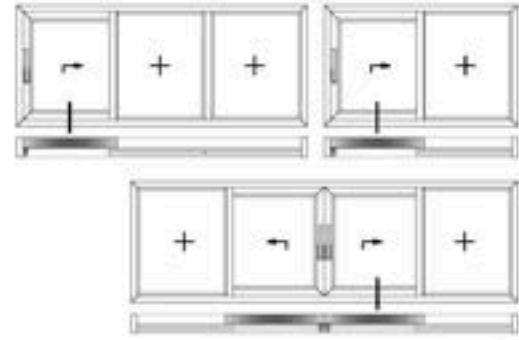

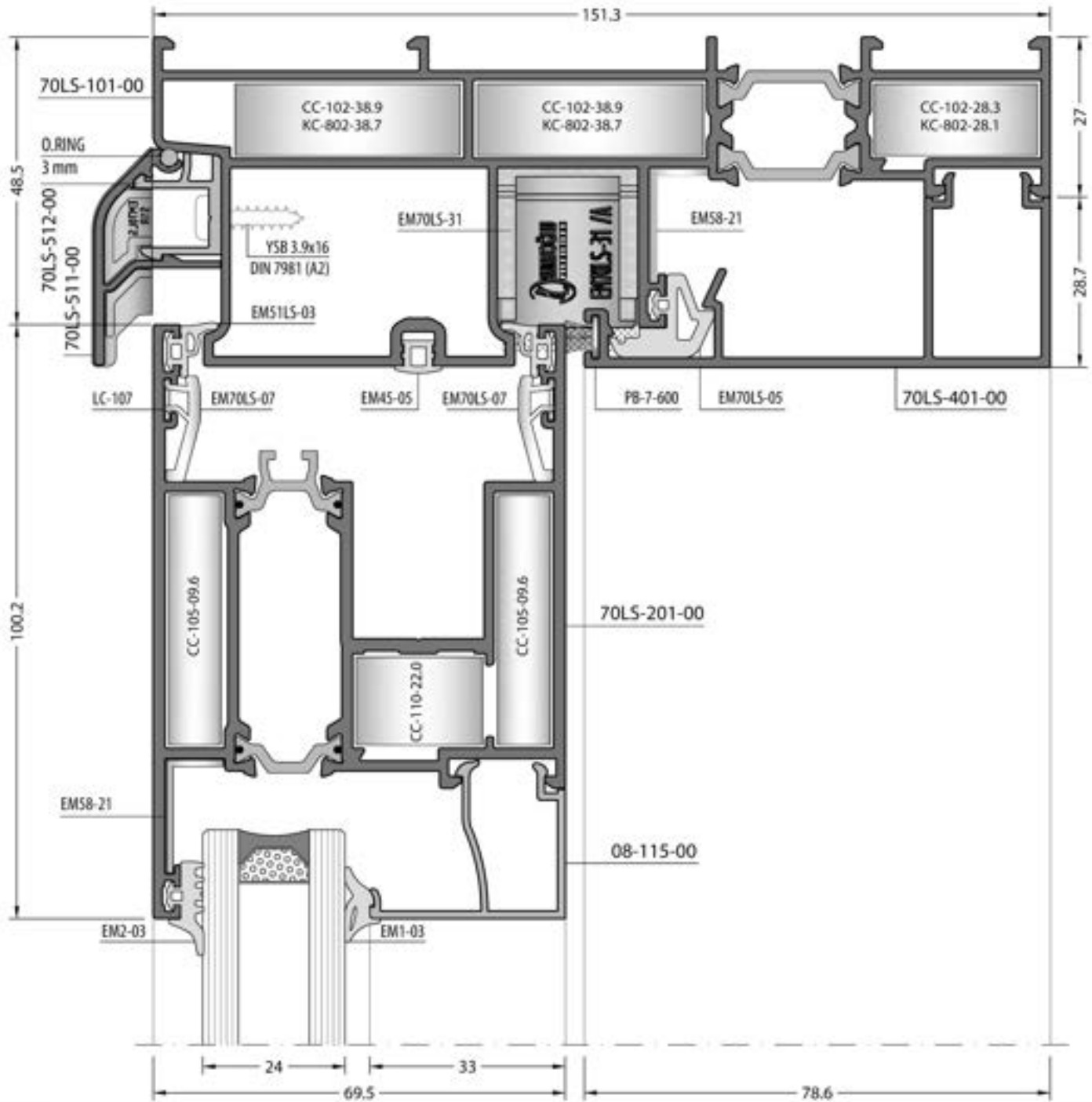
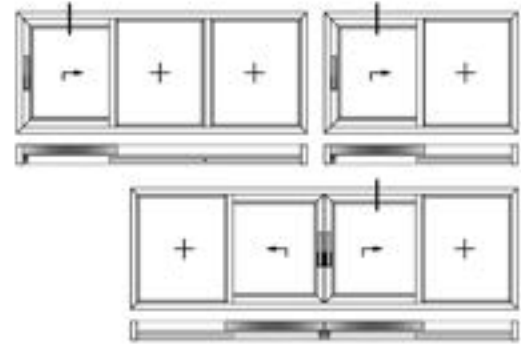

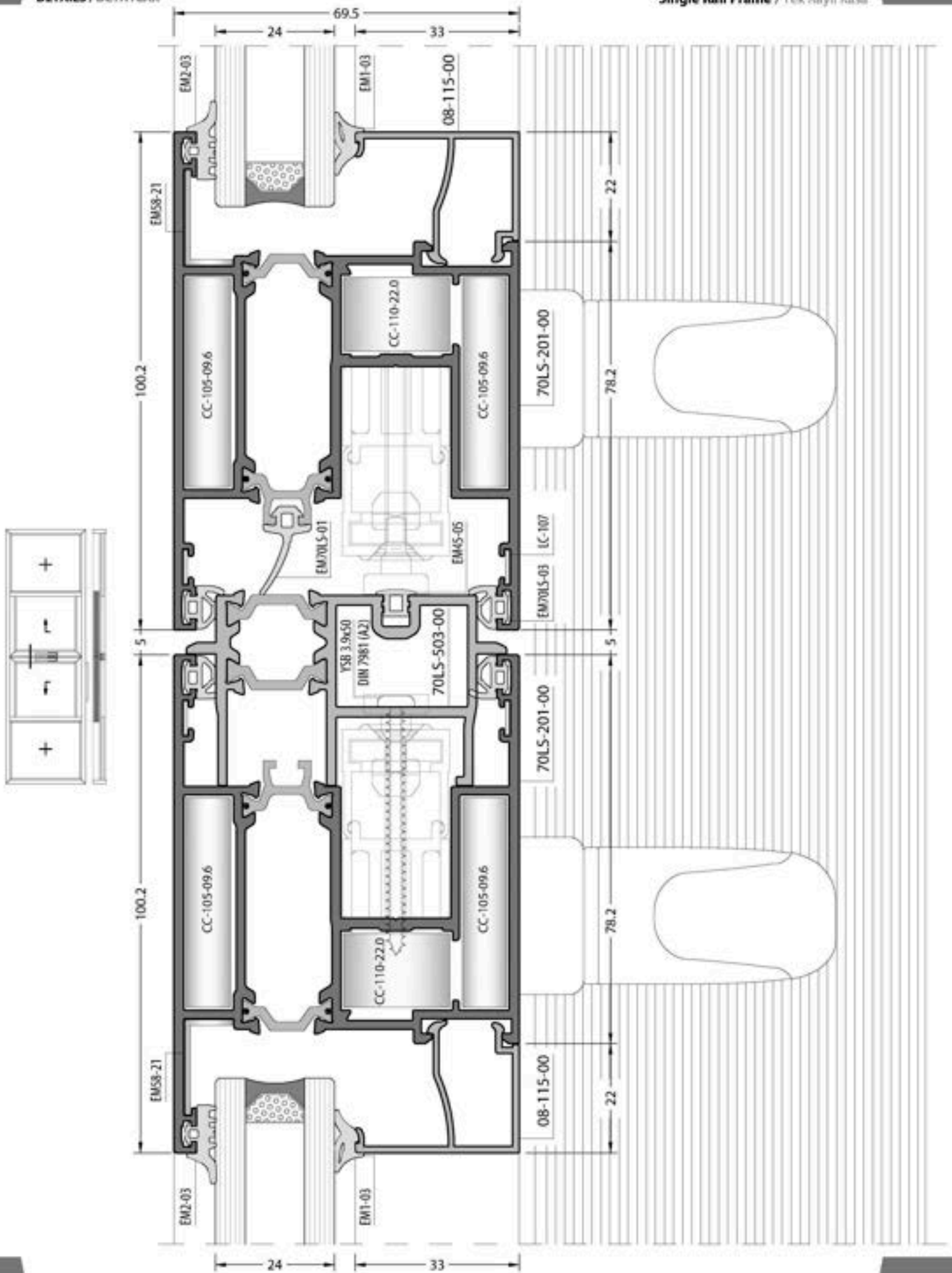

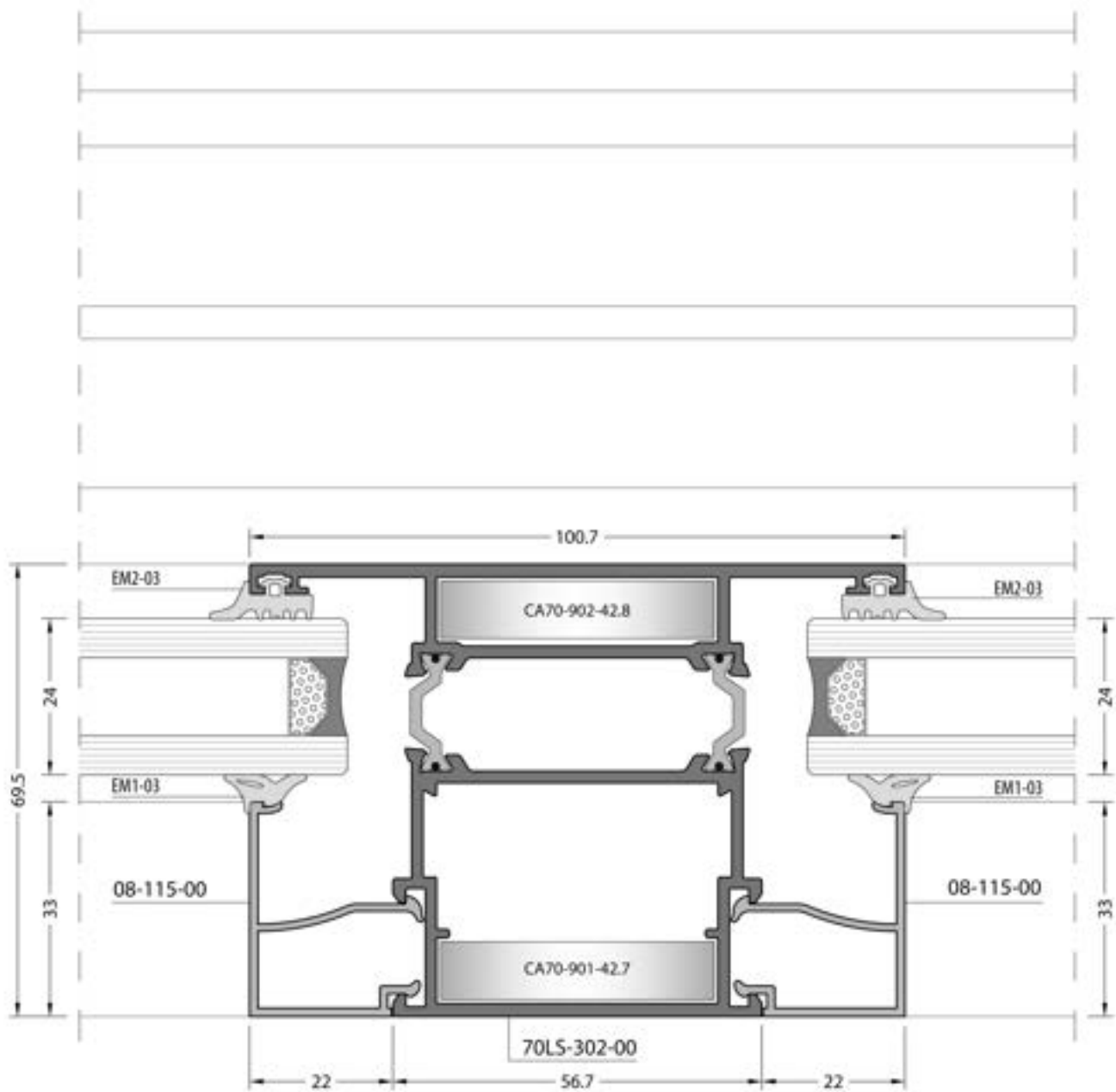
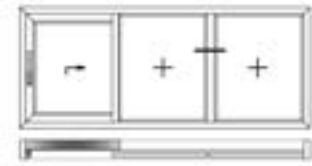

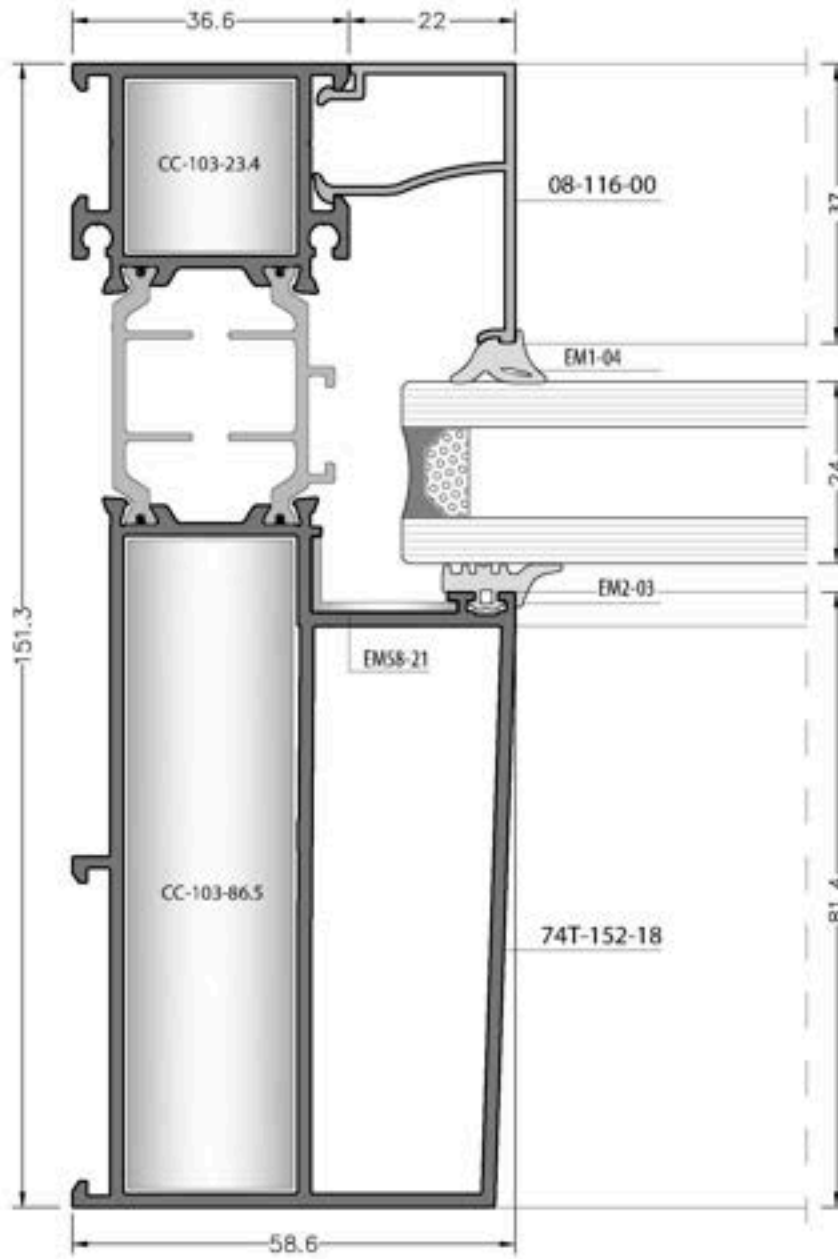
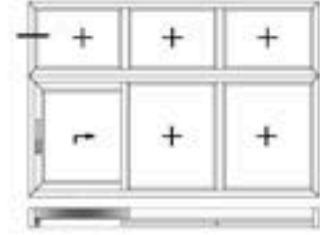

Please look at the 74T catalogue for 74T-152-18 profile glazing combinations.
74T-152-18 profilinin cam kombinasyonu için 74T kataloğuna bakınız.

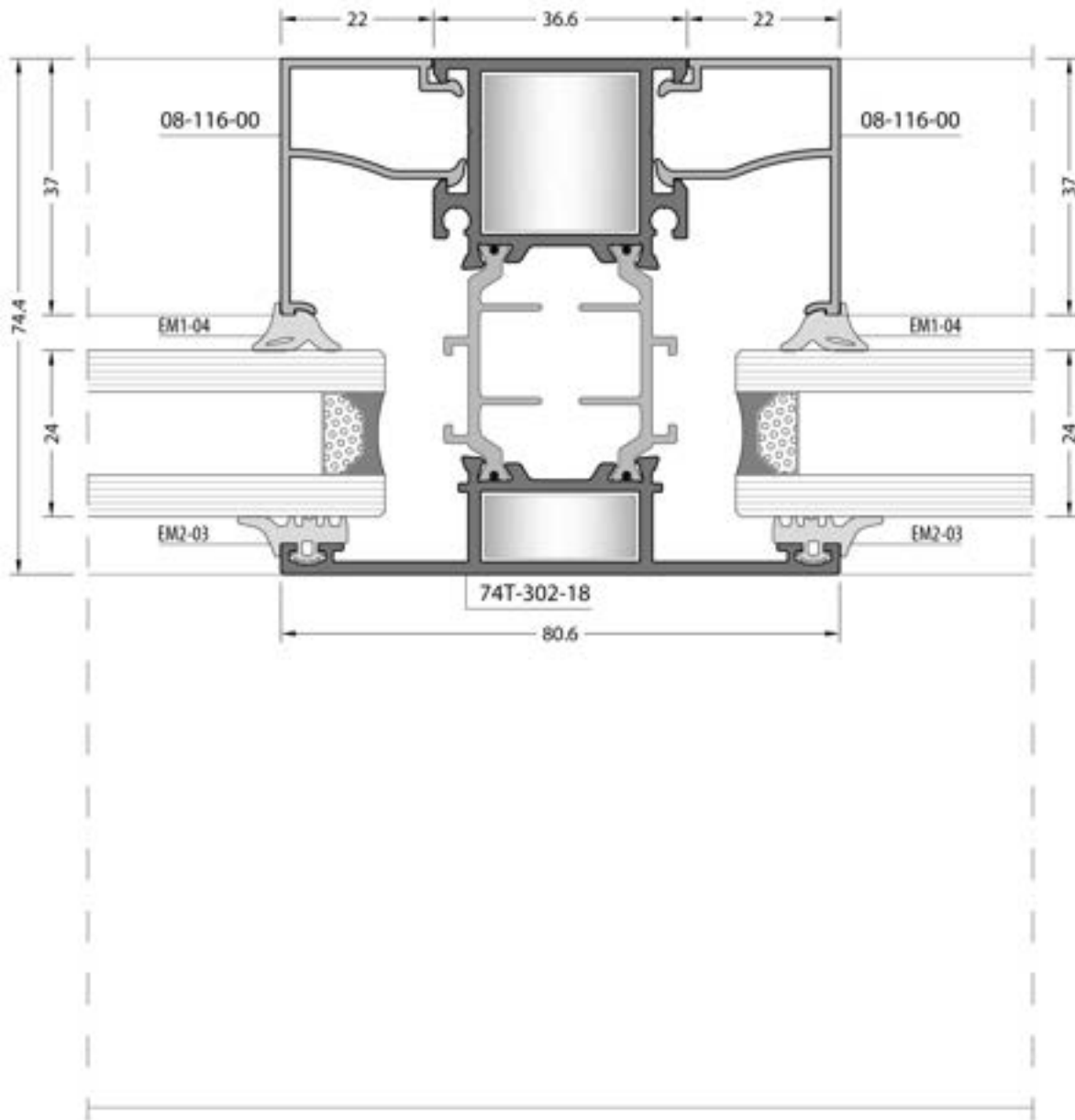
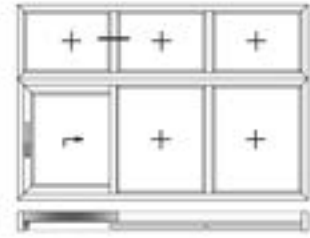

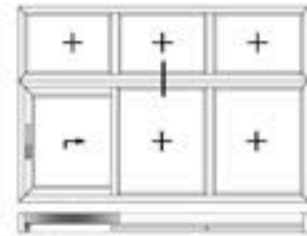

Please look at the 74T catalogue for 74T-152-18
profile glazing combinations.

74T-152-18 profilinin cam kombinasyonu için
74T kataloğuna bakınız.

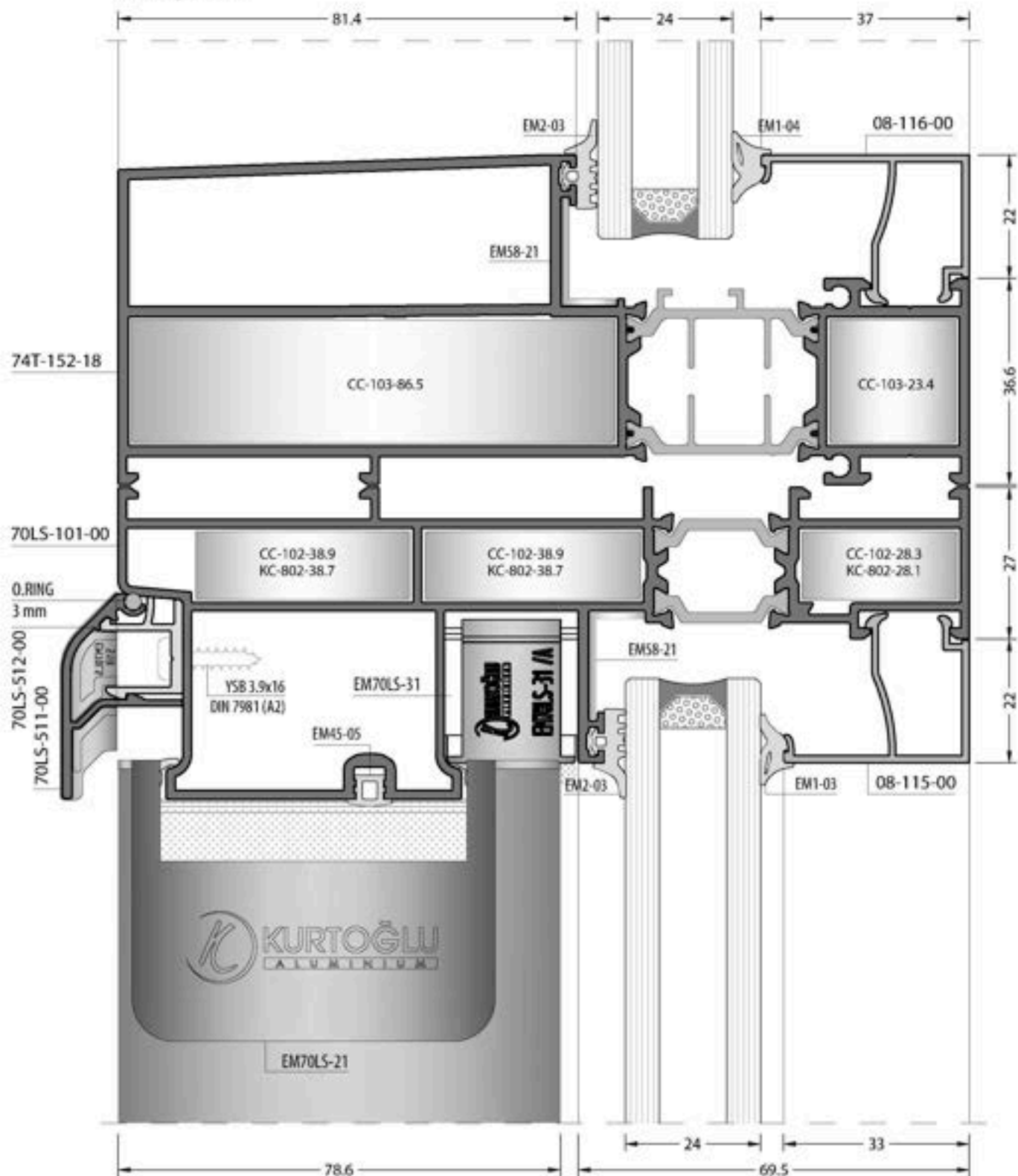

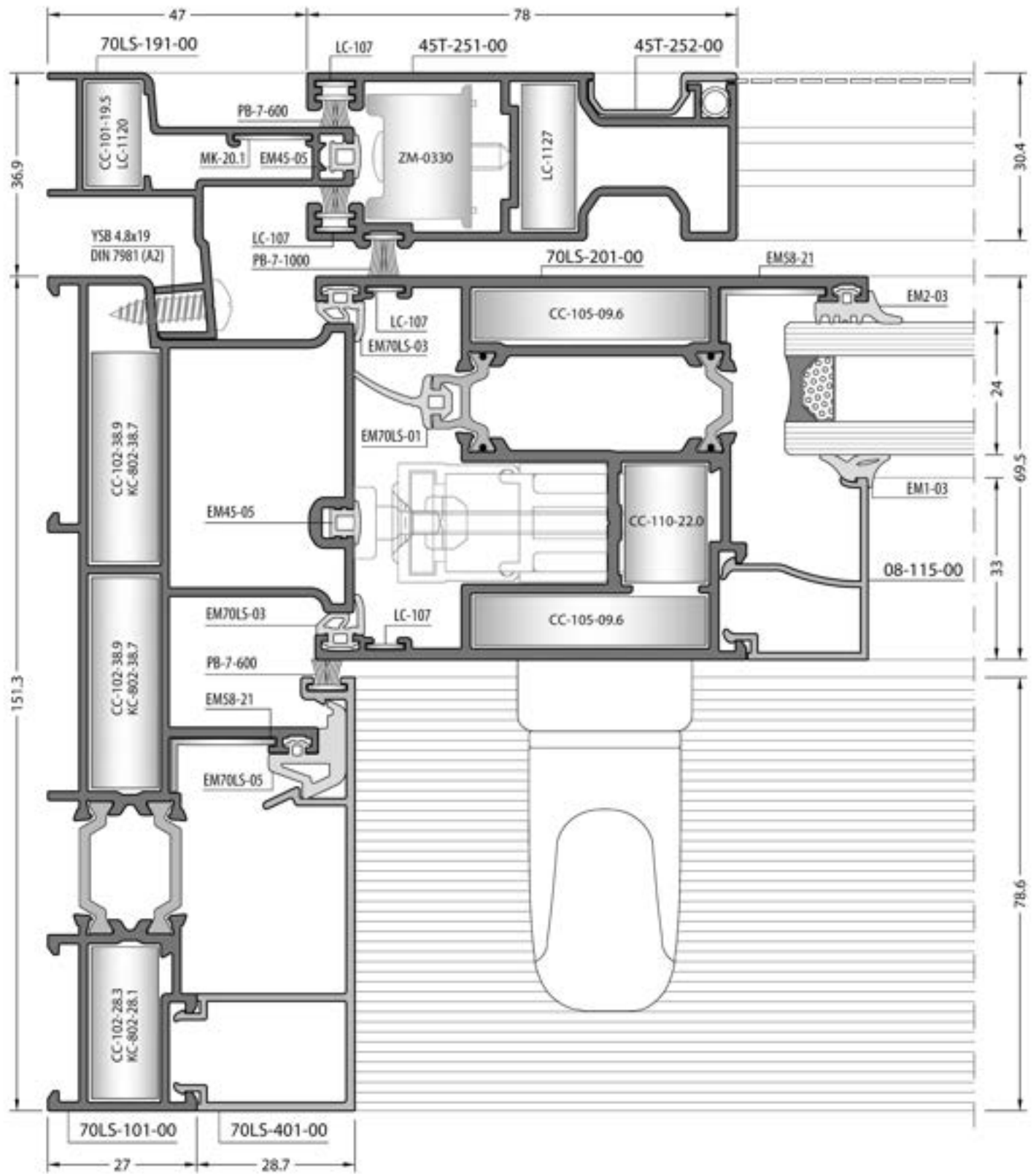
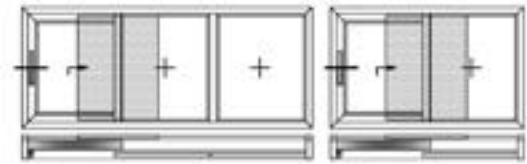

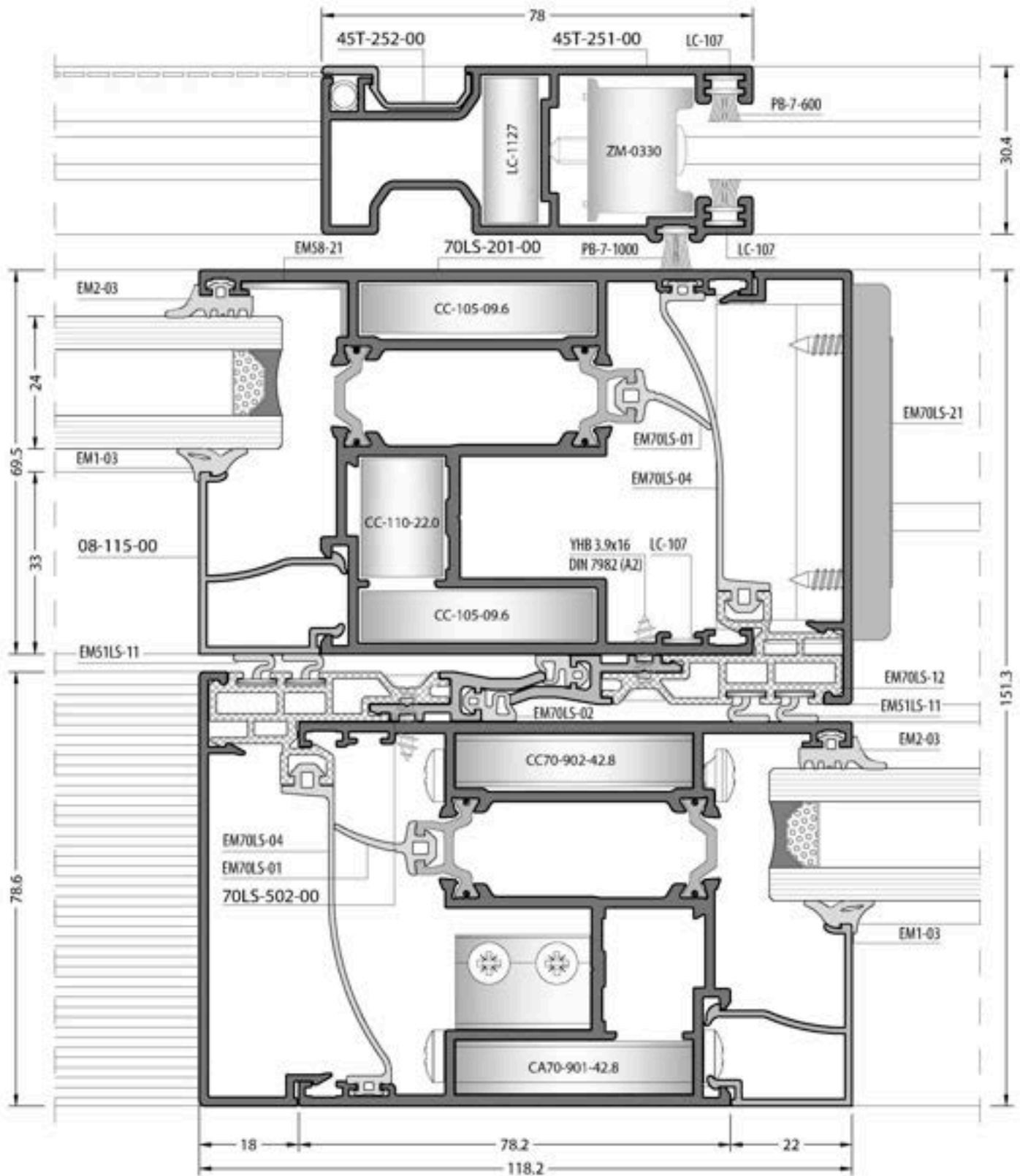
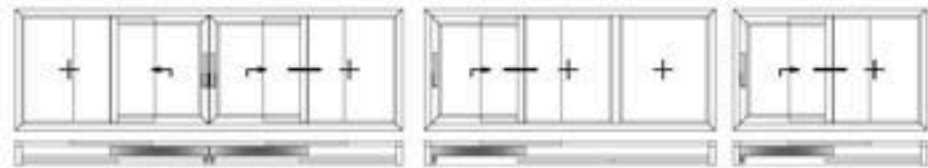

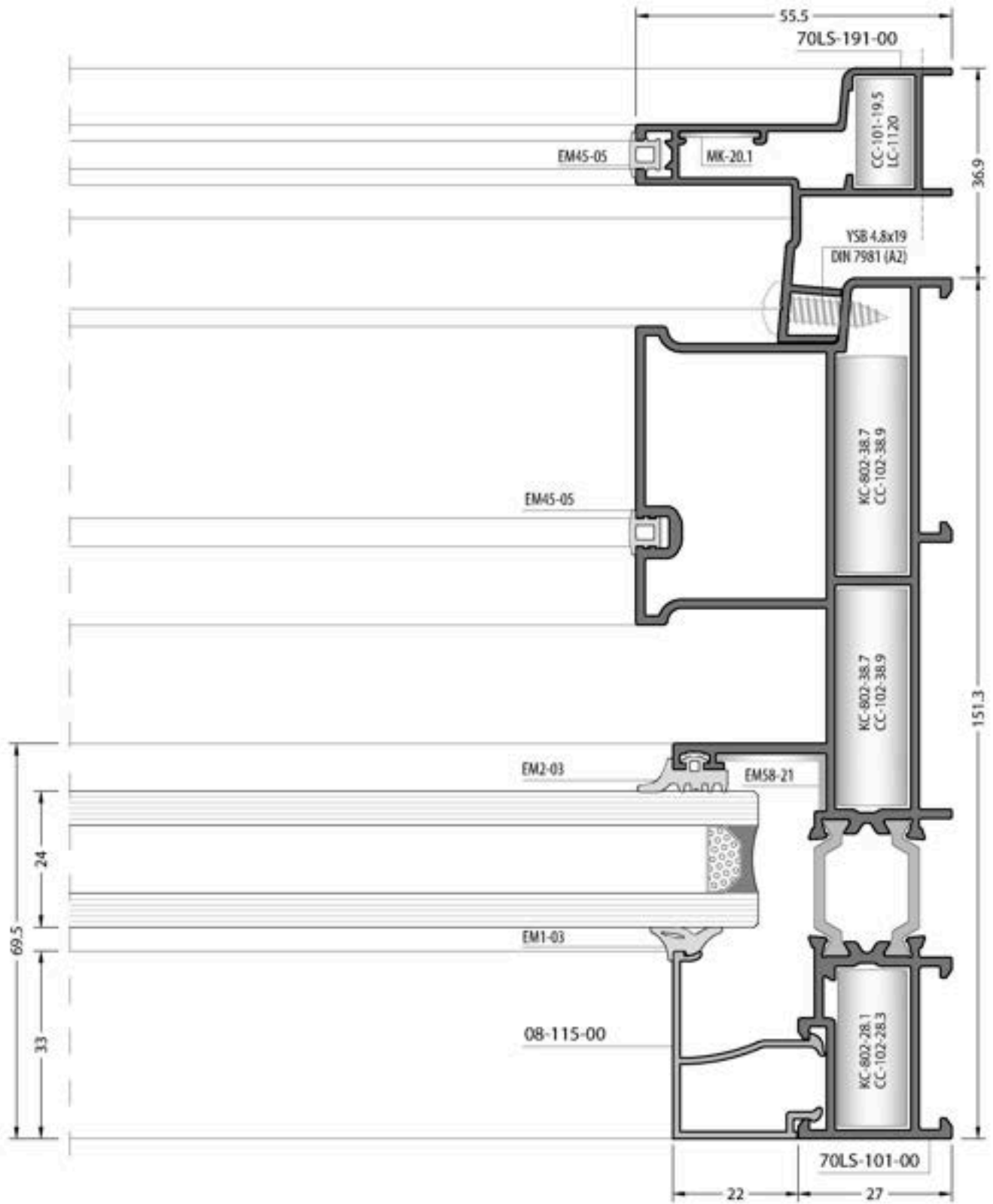
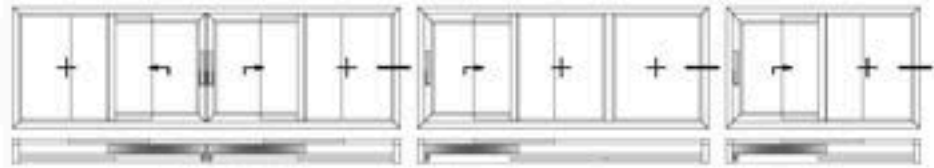

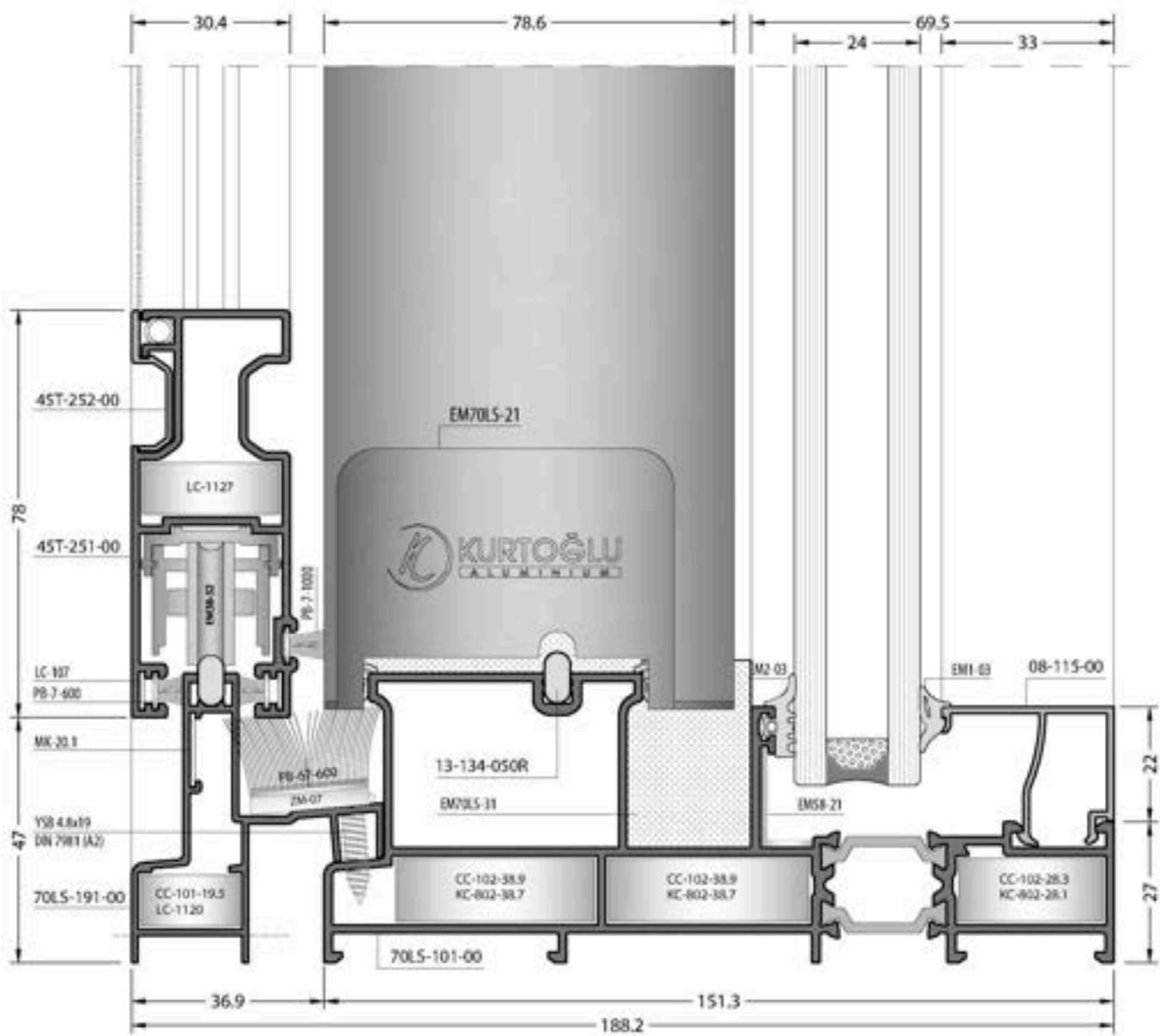
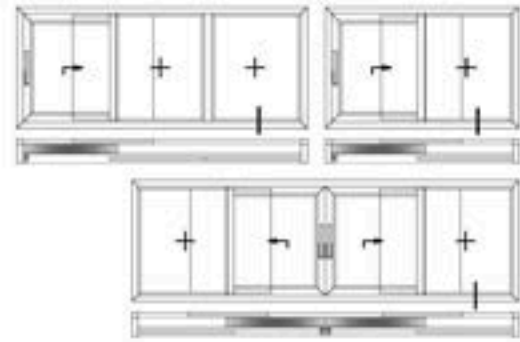

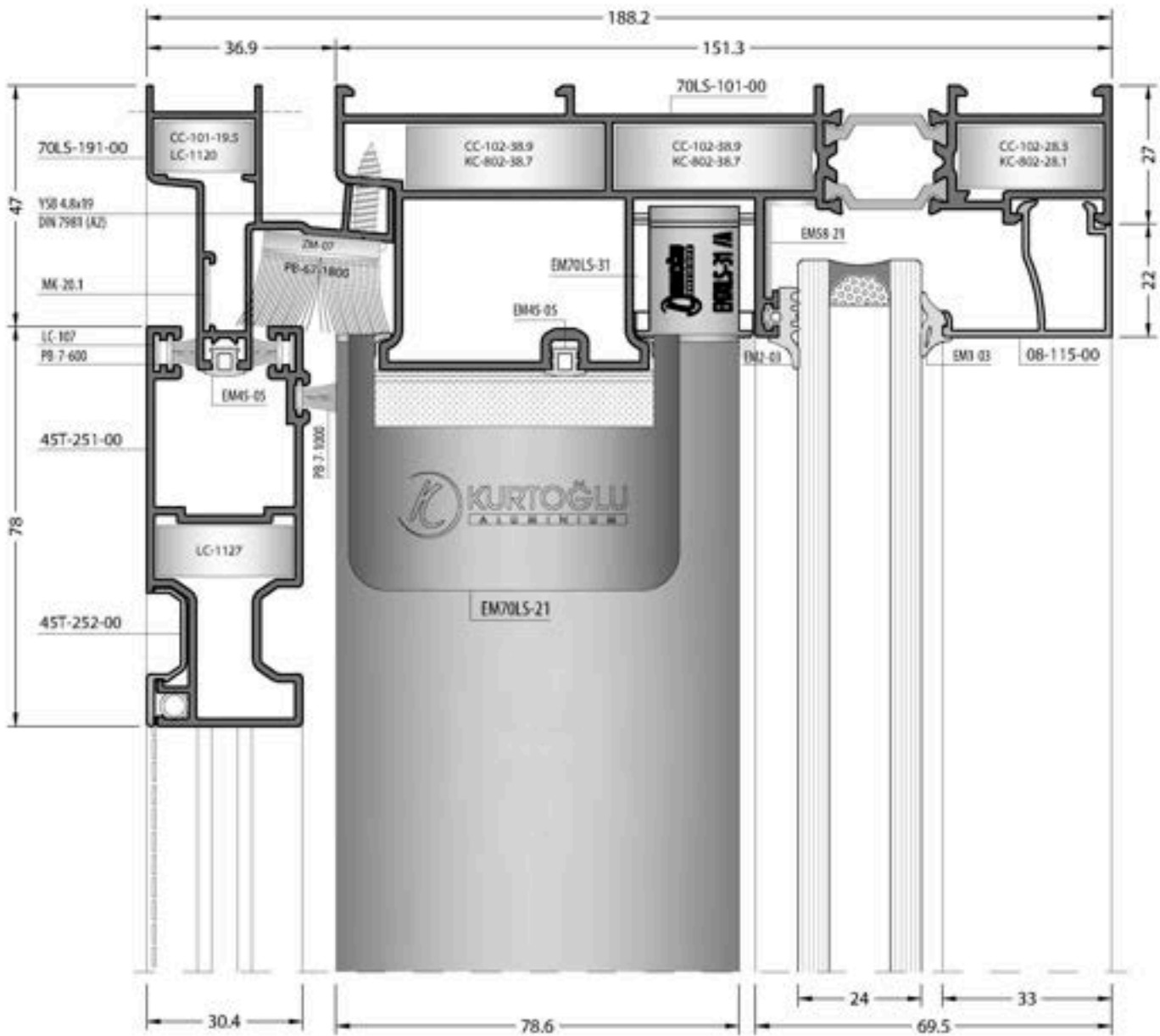
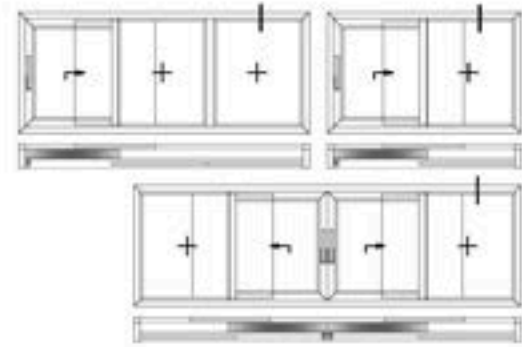

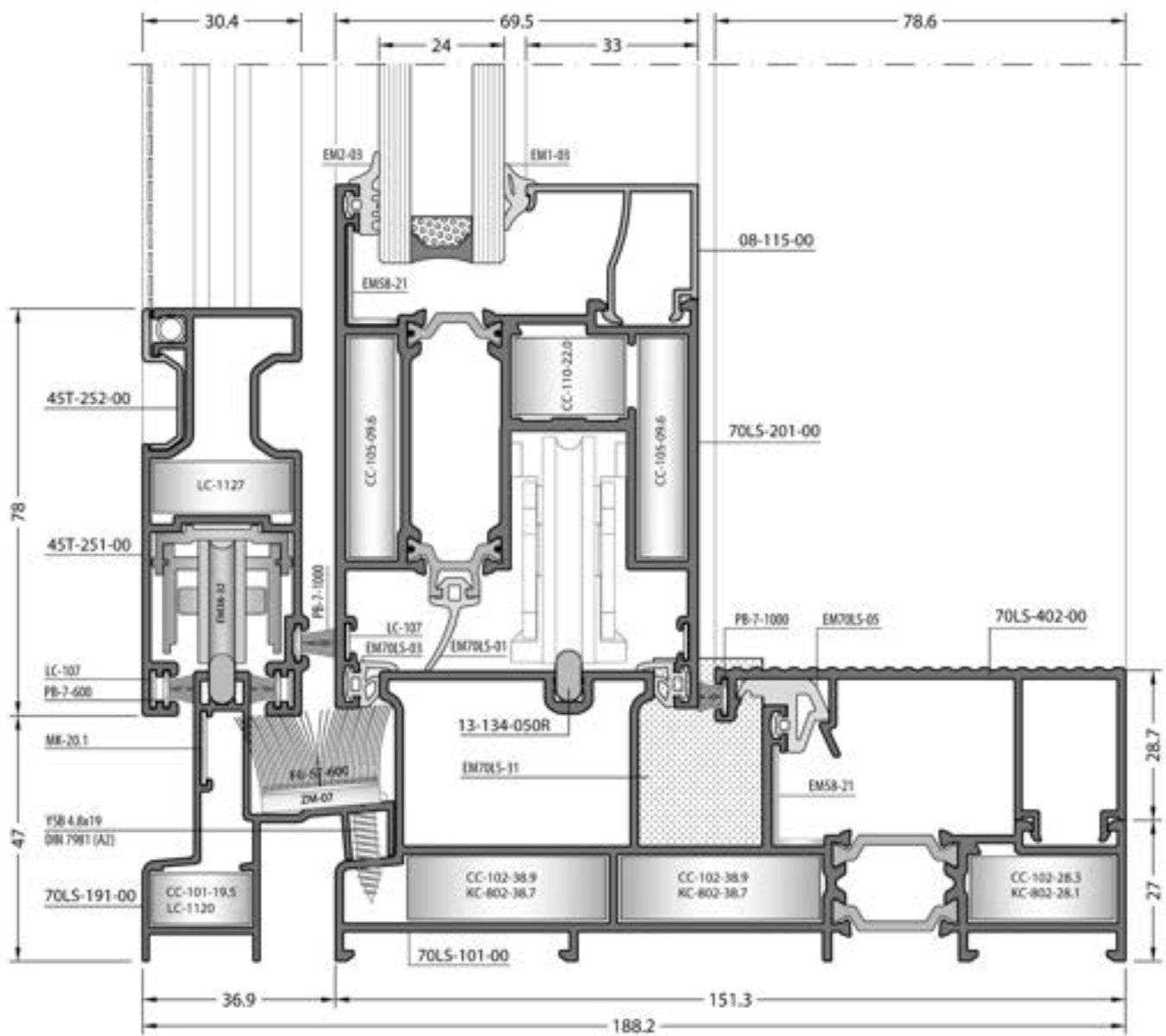
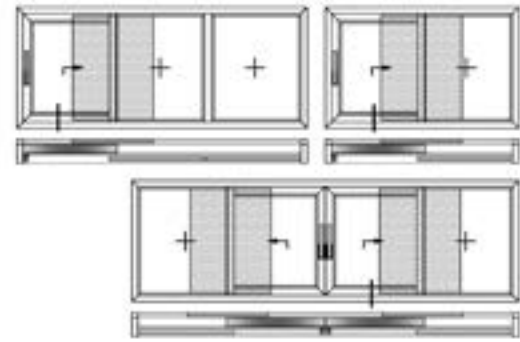

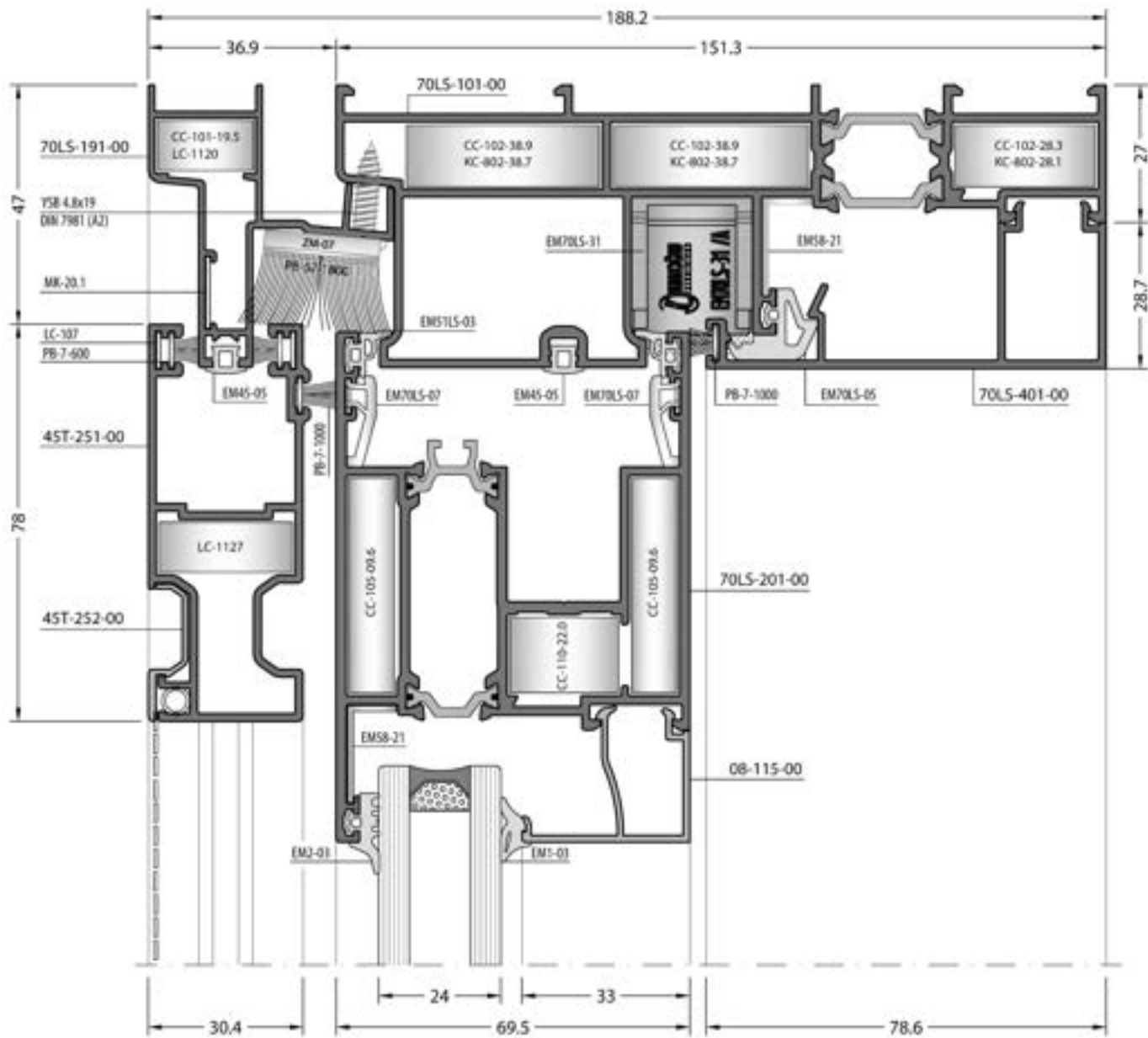
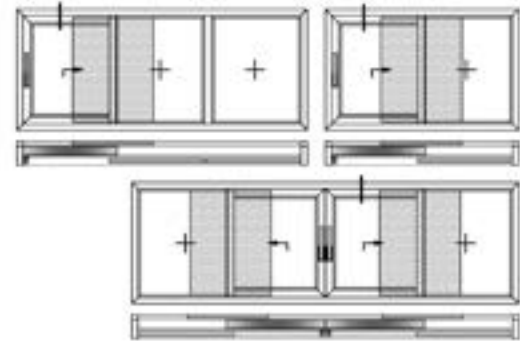

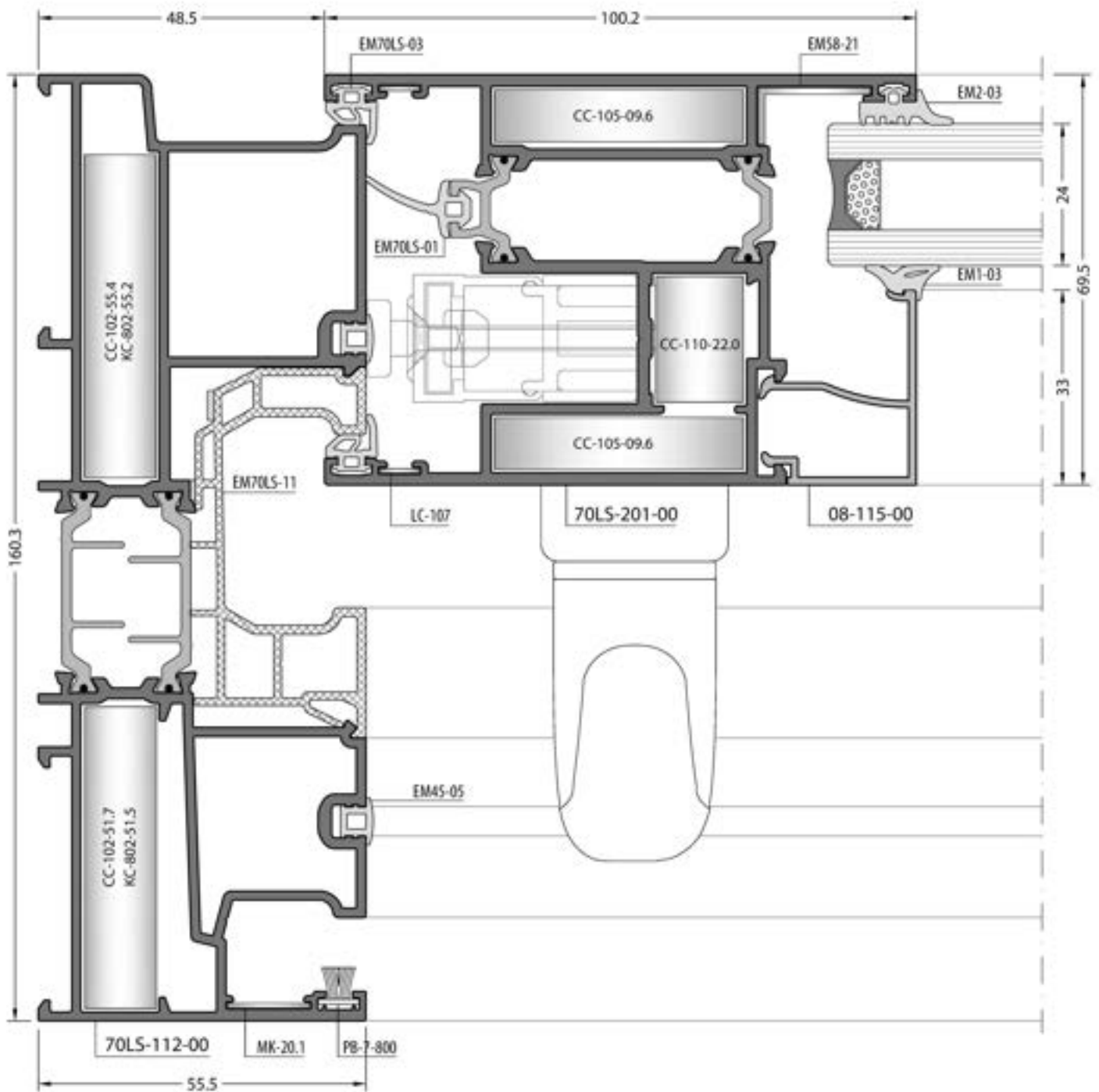
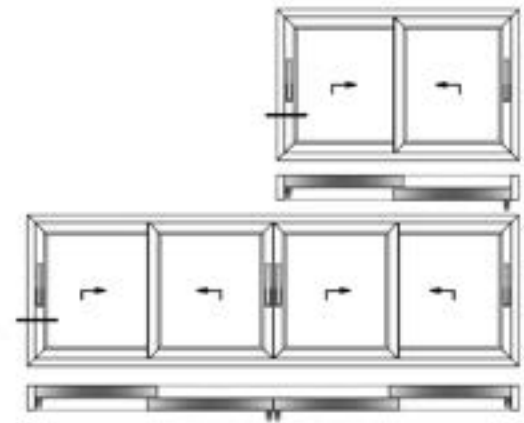

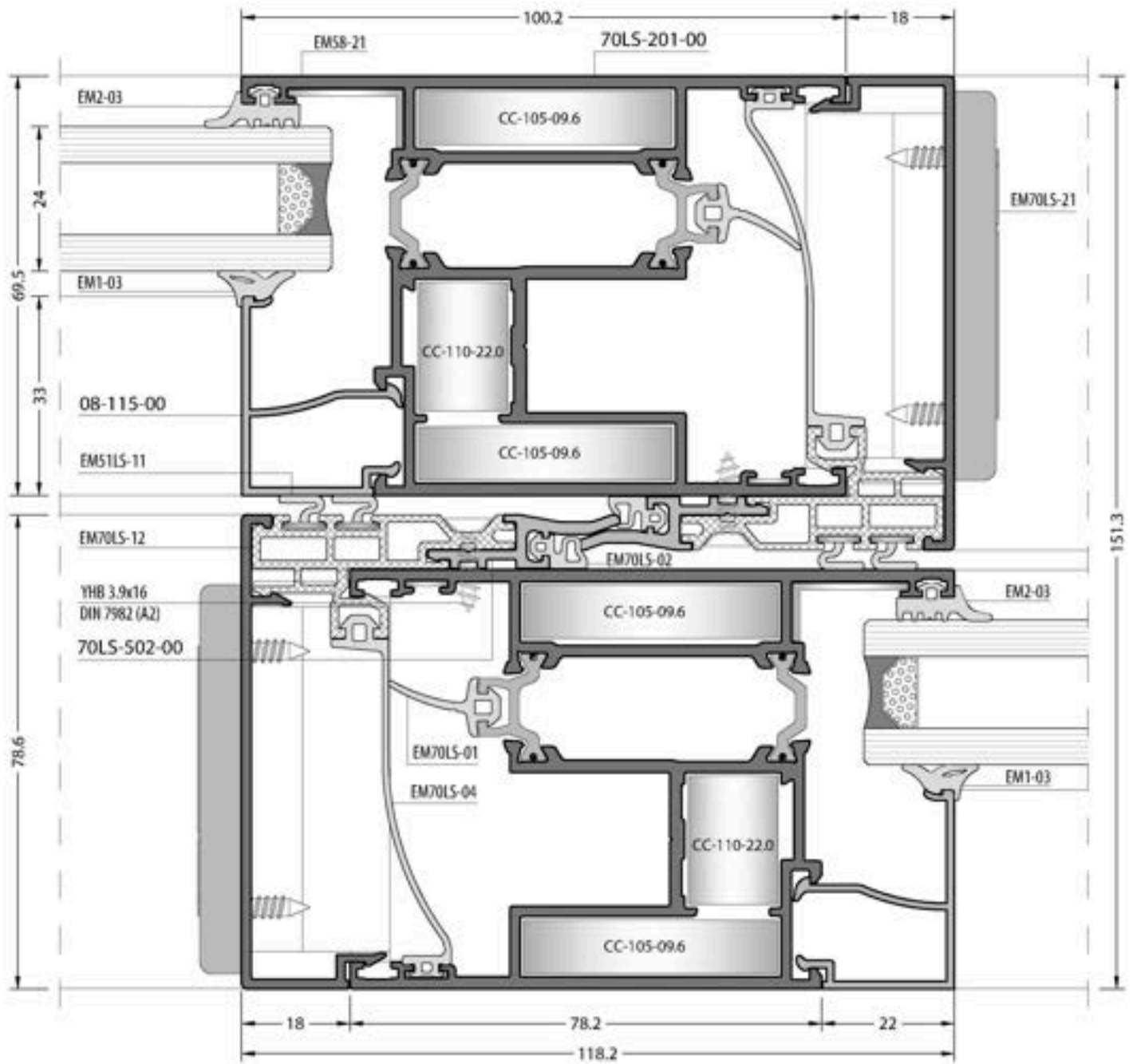
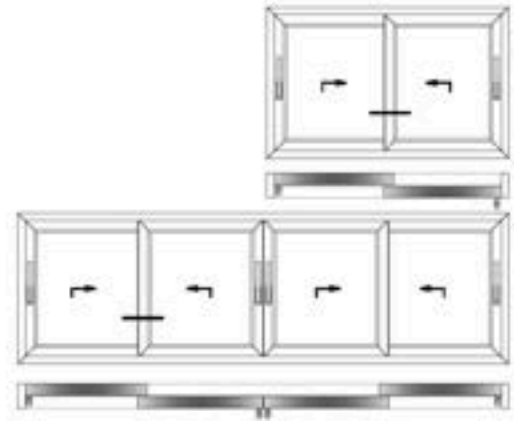

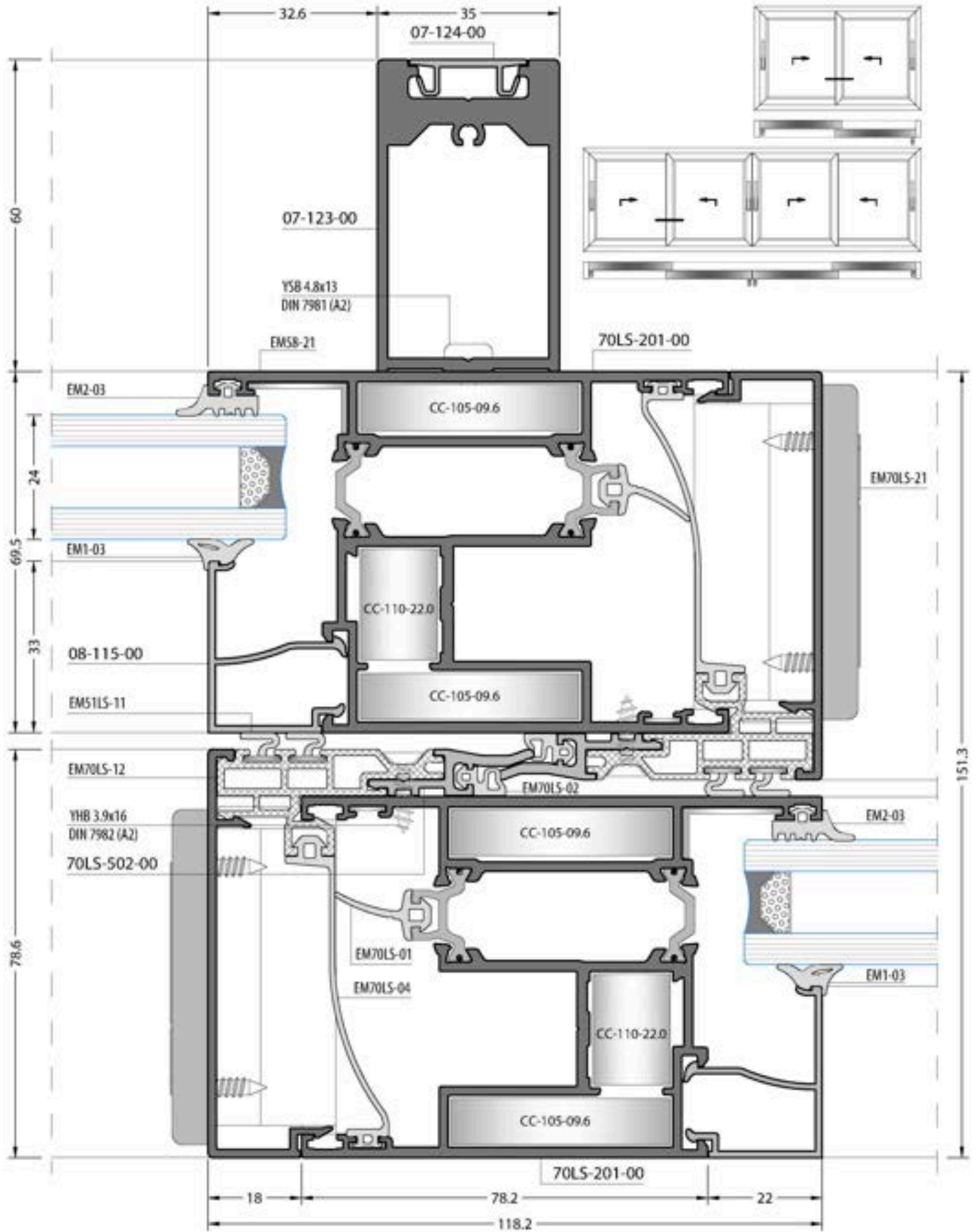

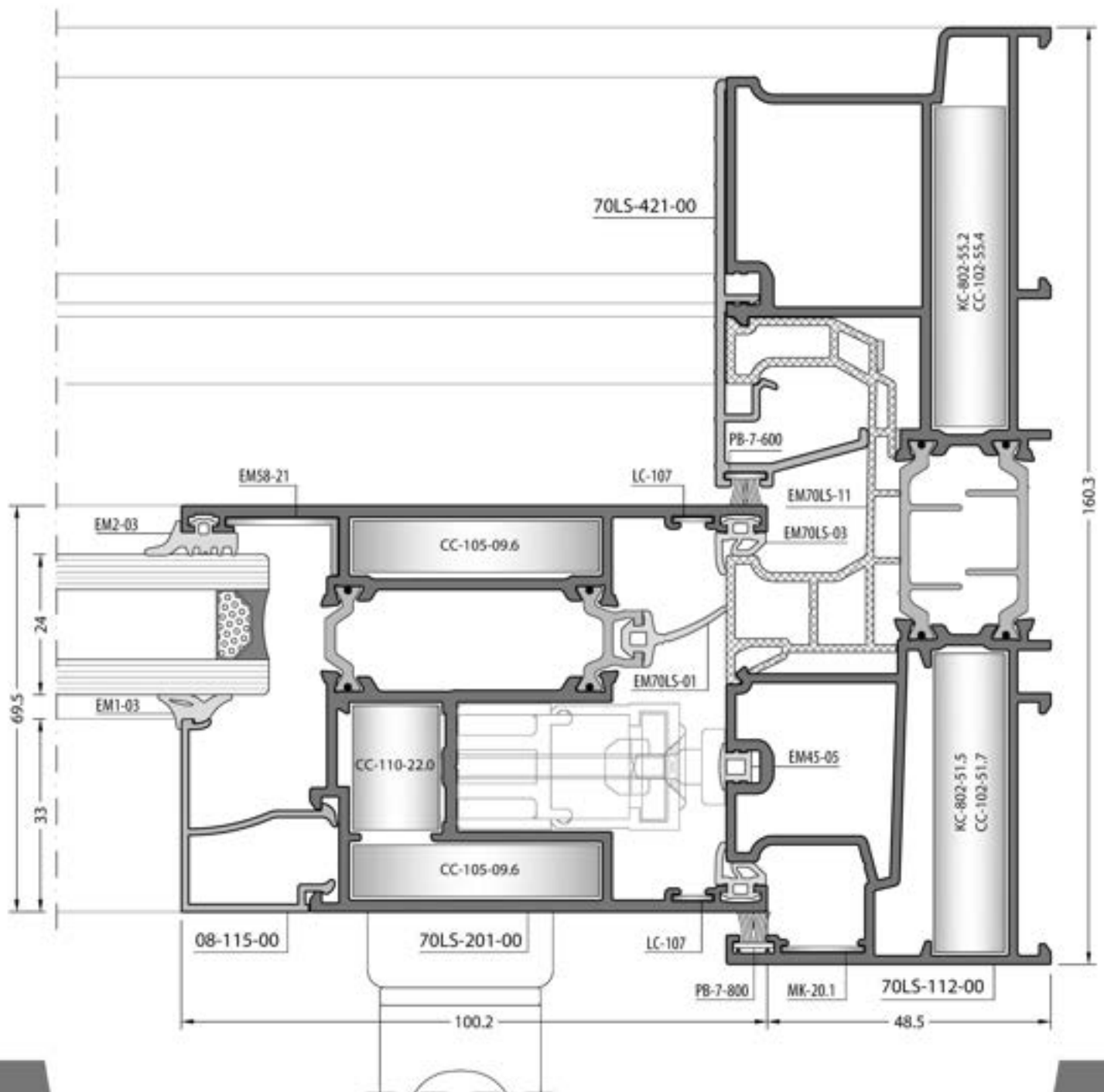
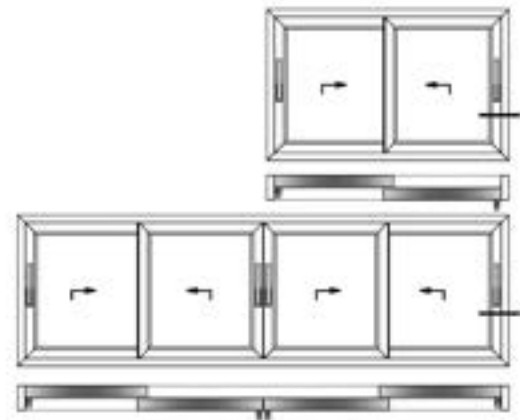

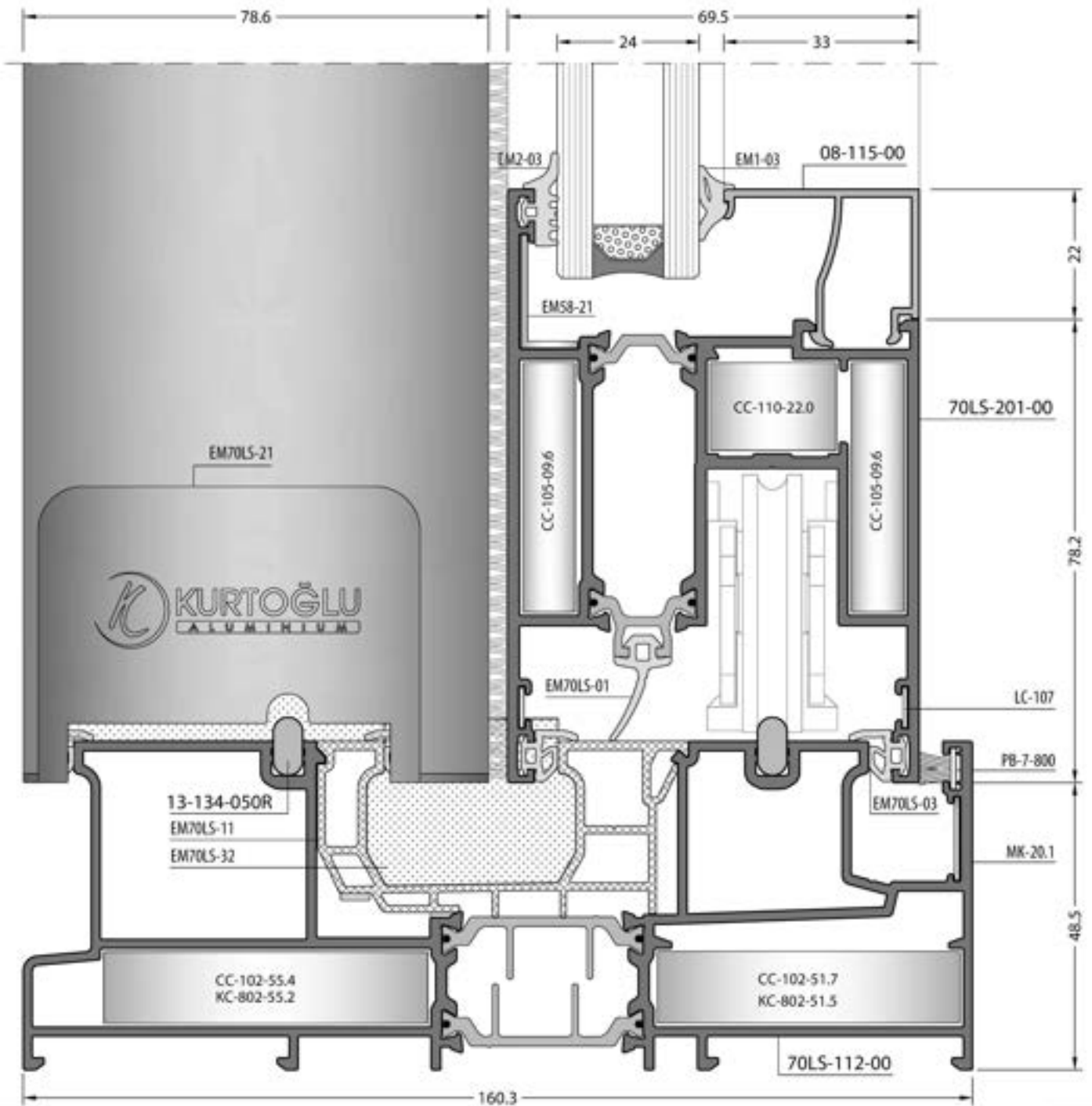
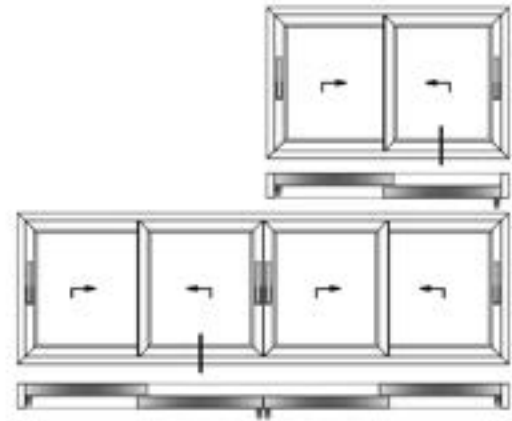

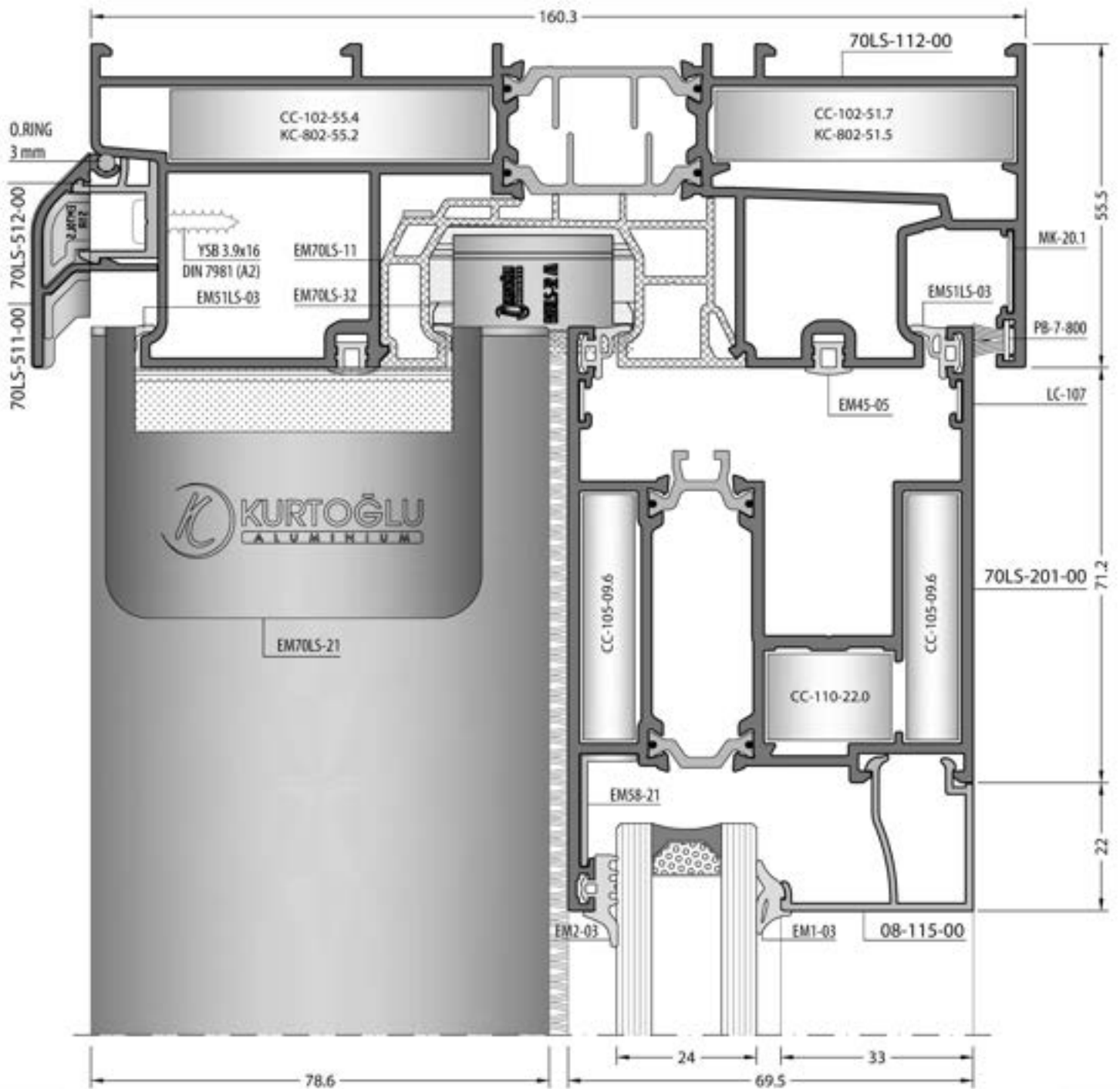
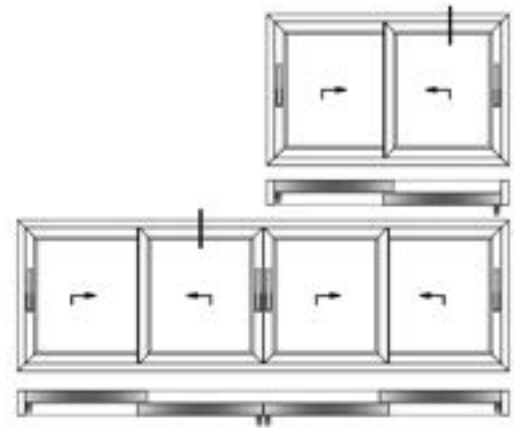

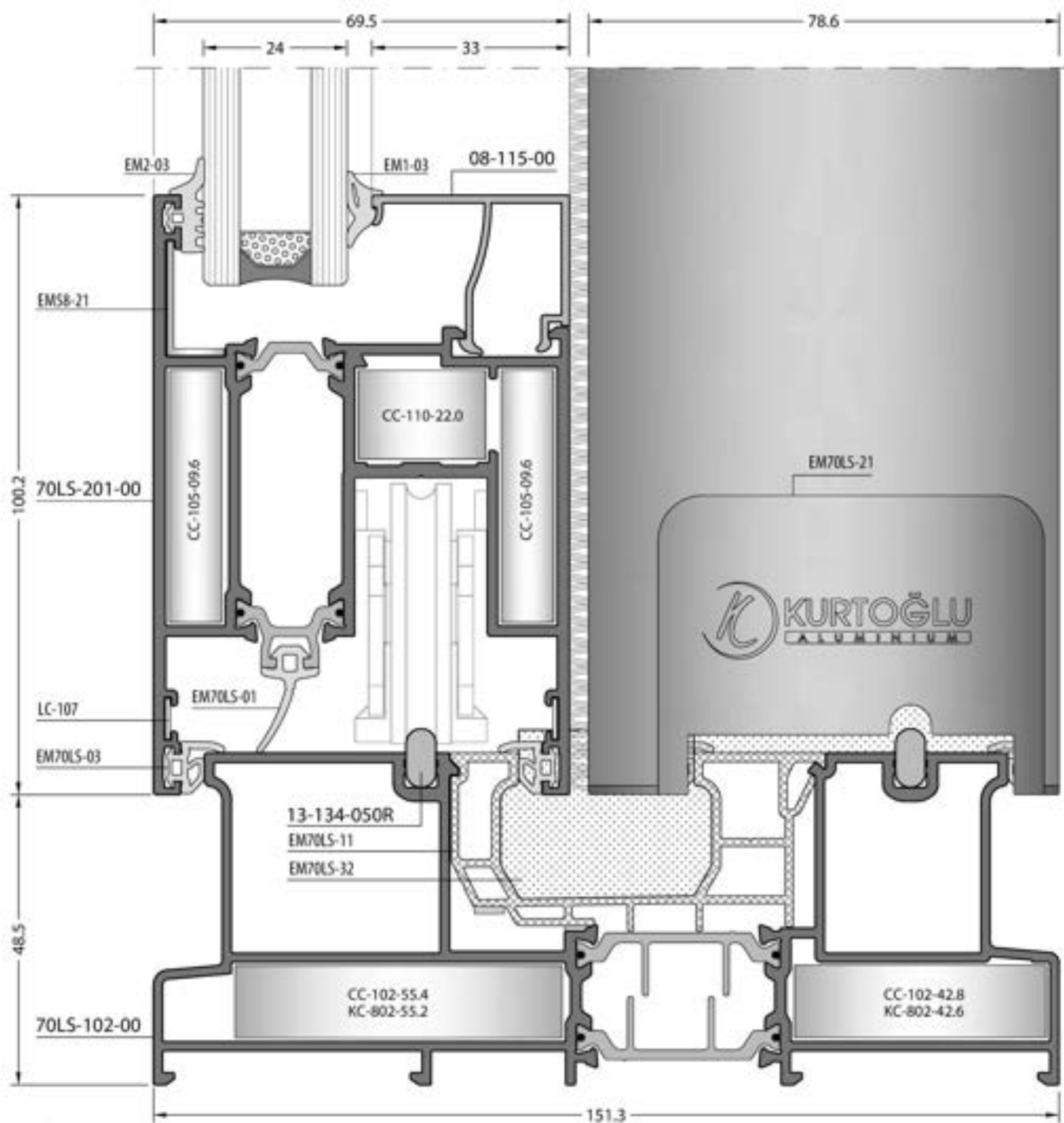
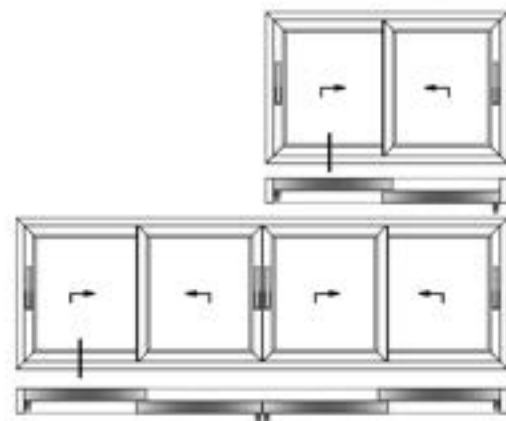

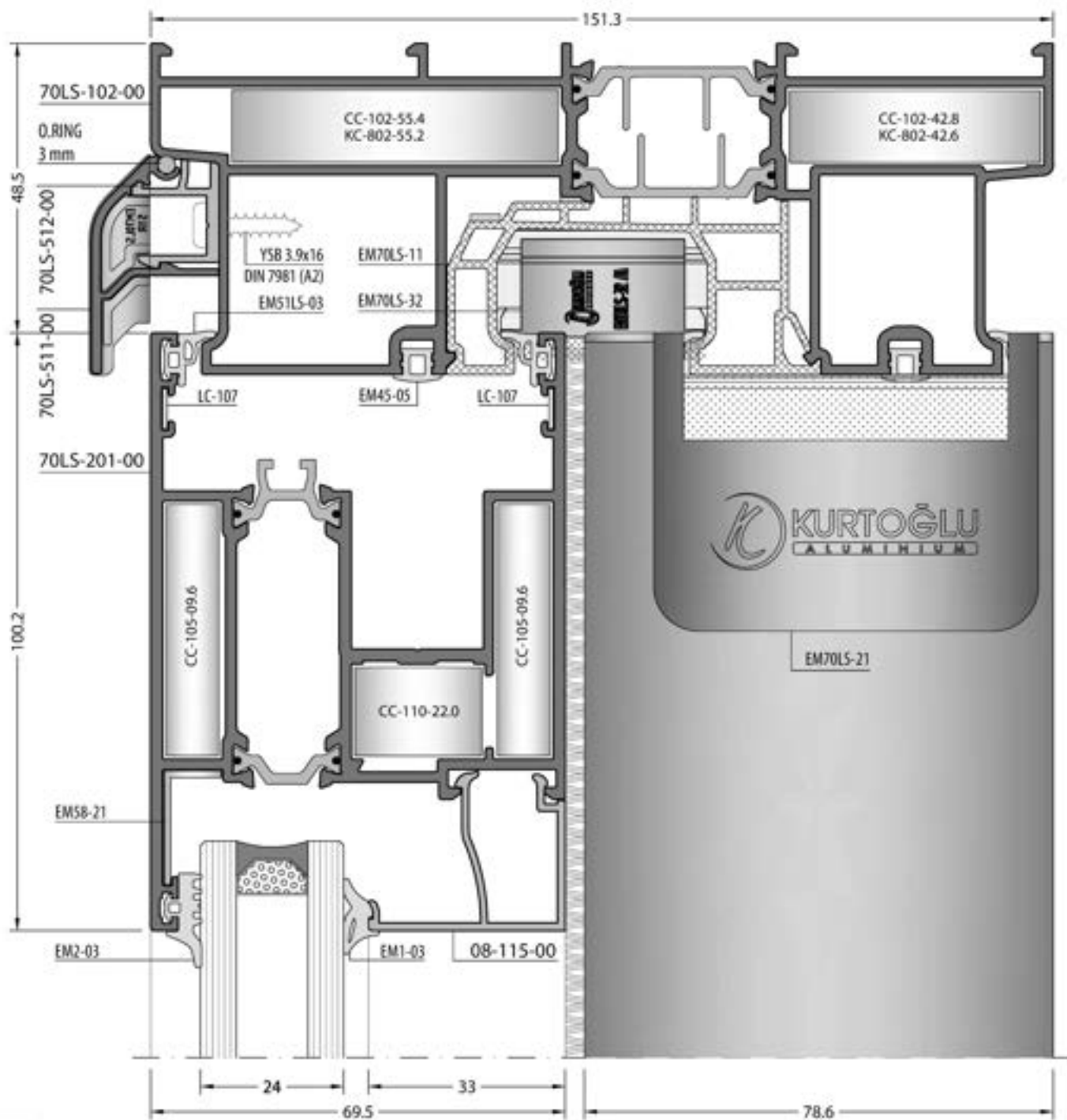
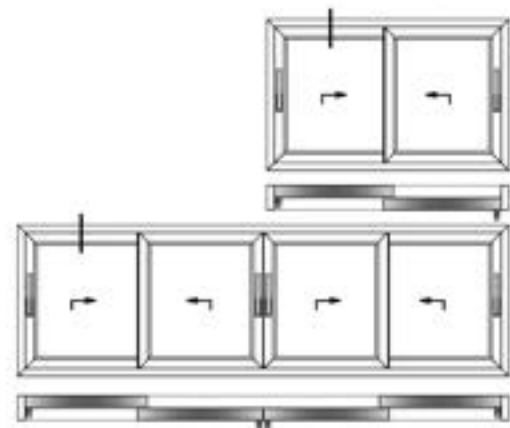

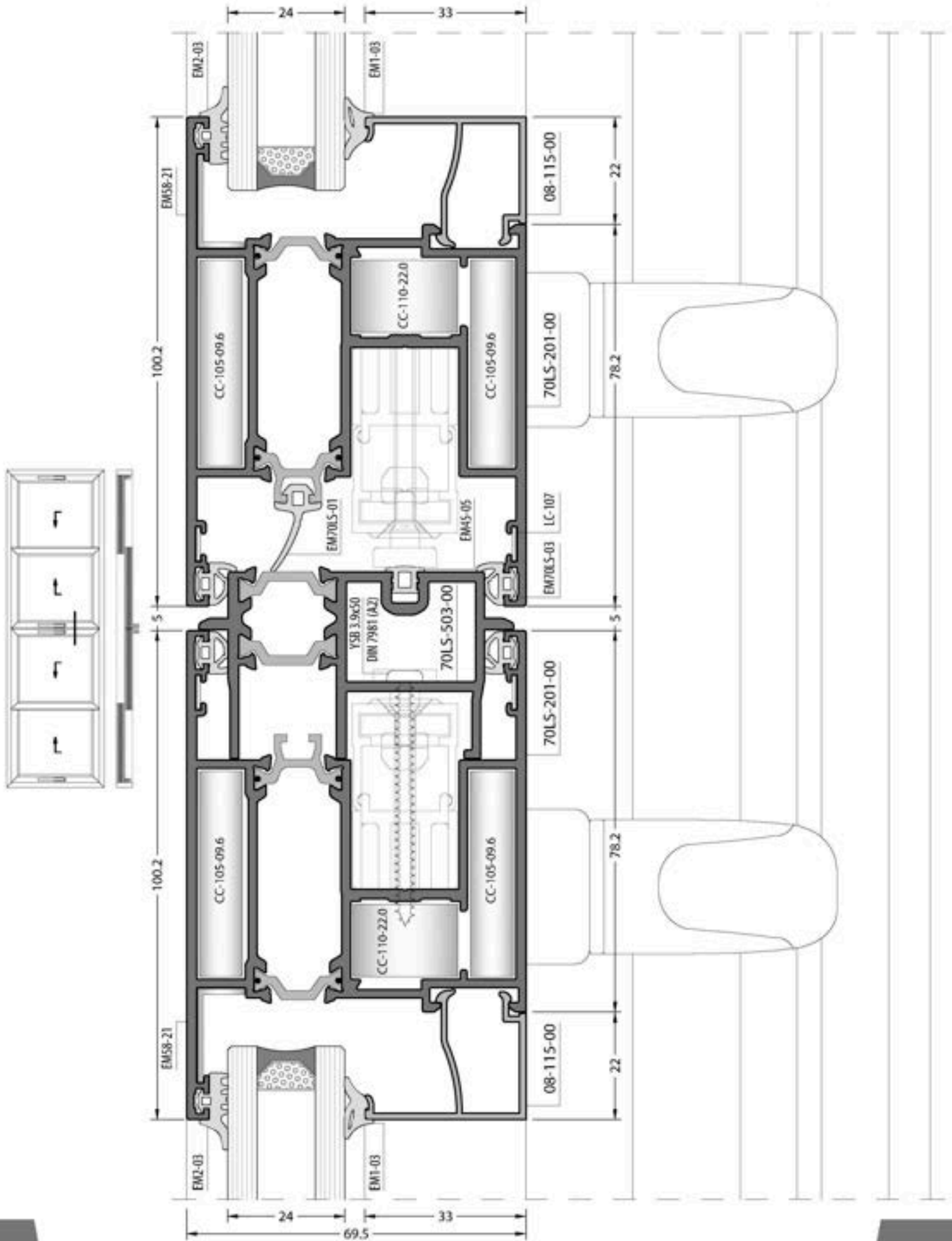

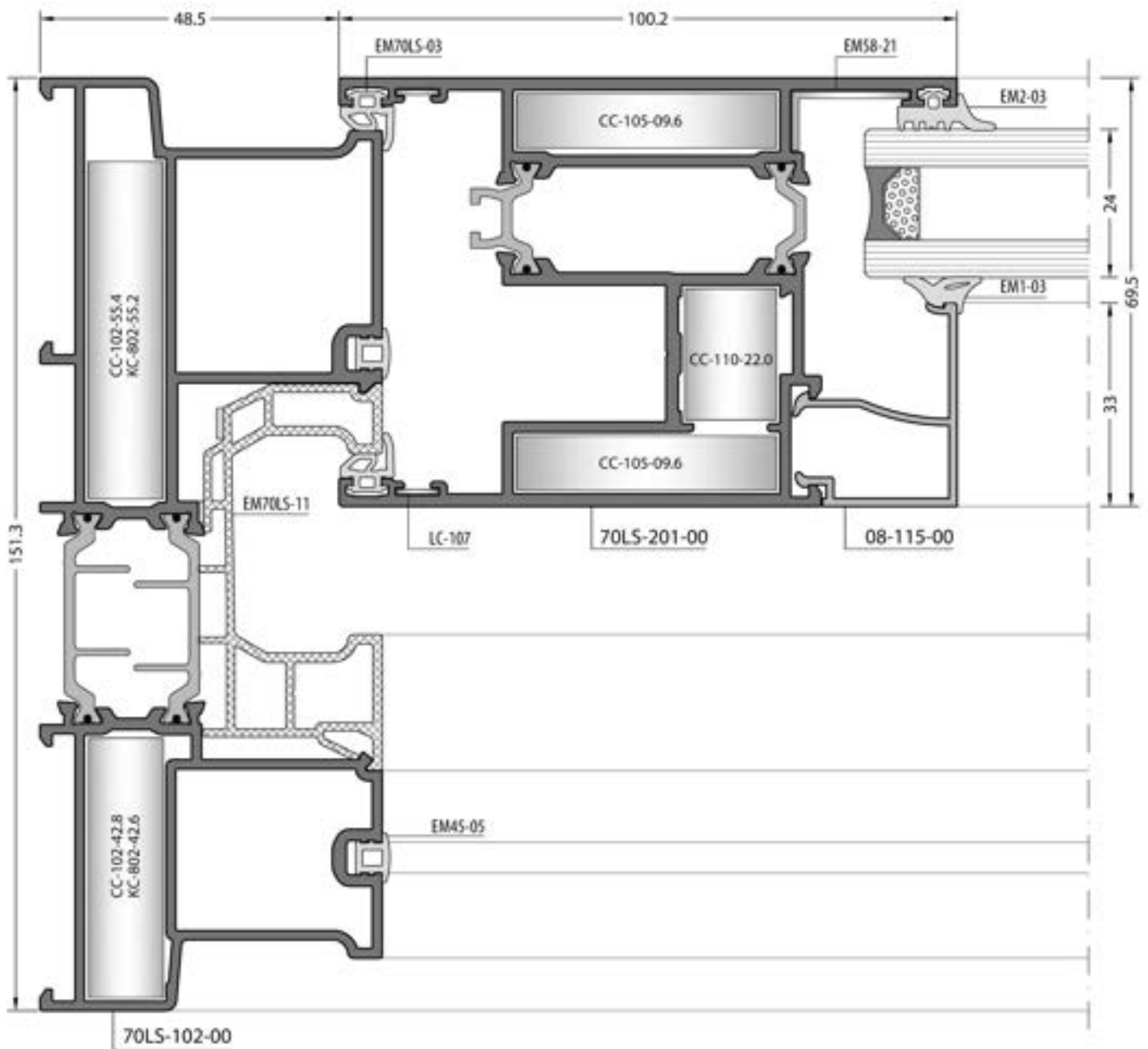
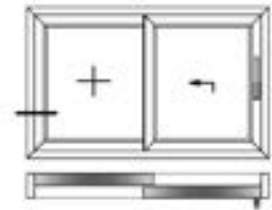

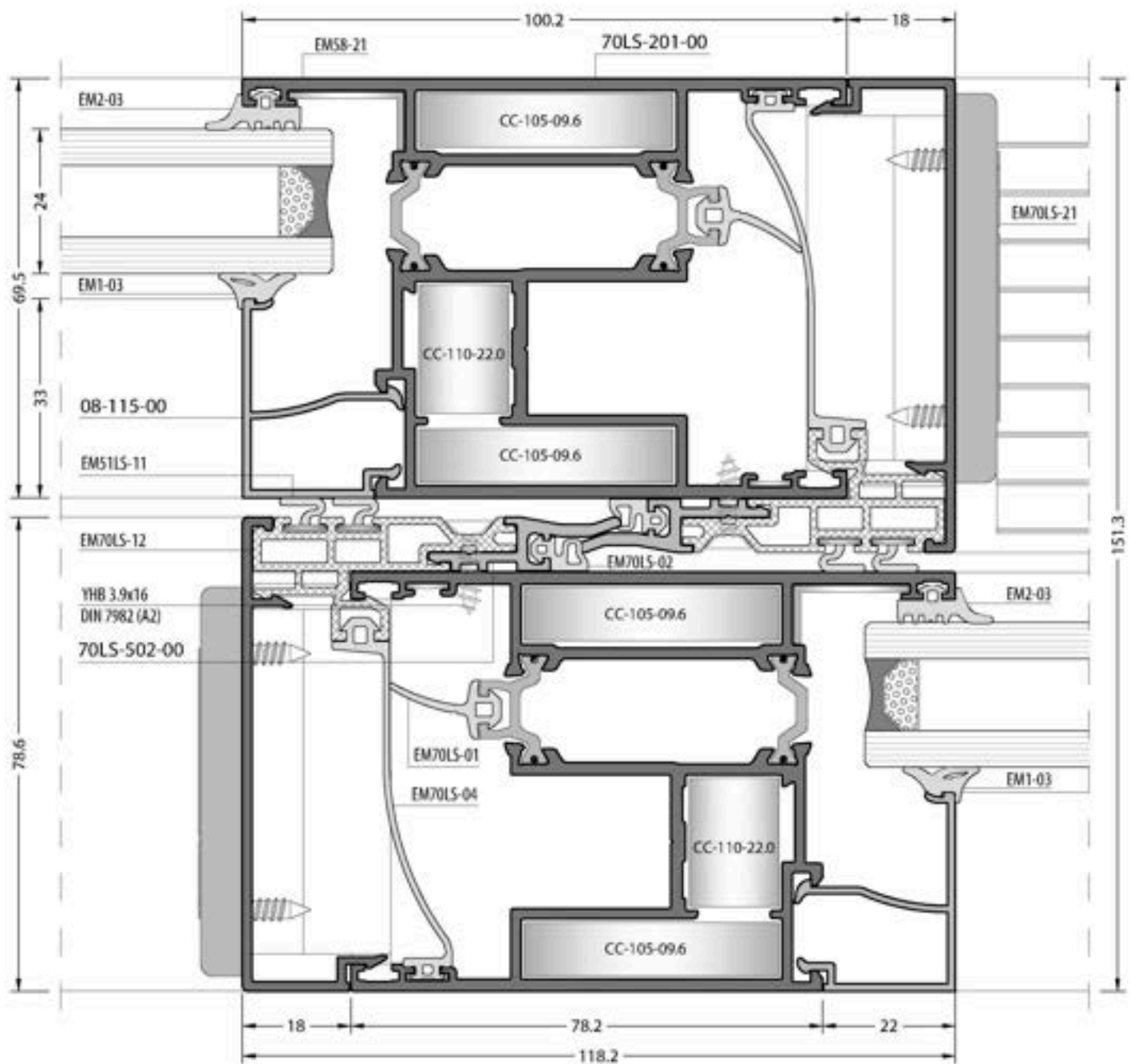
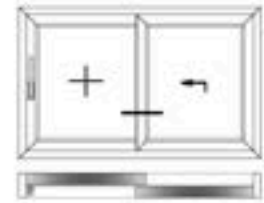

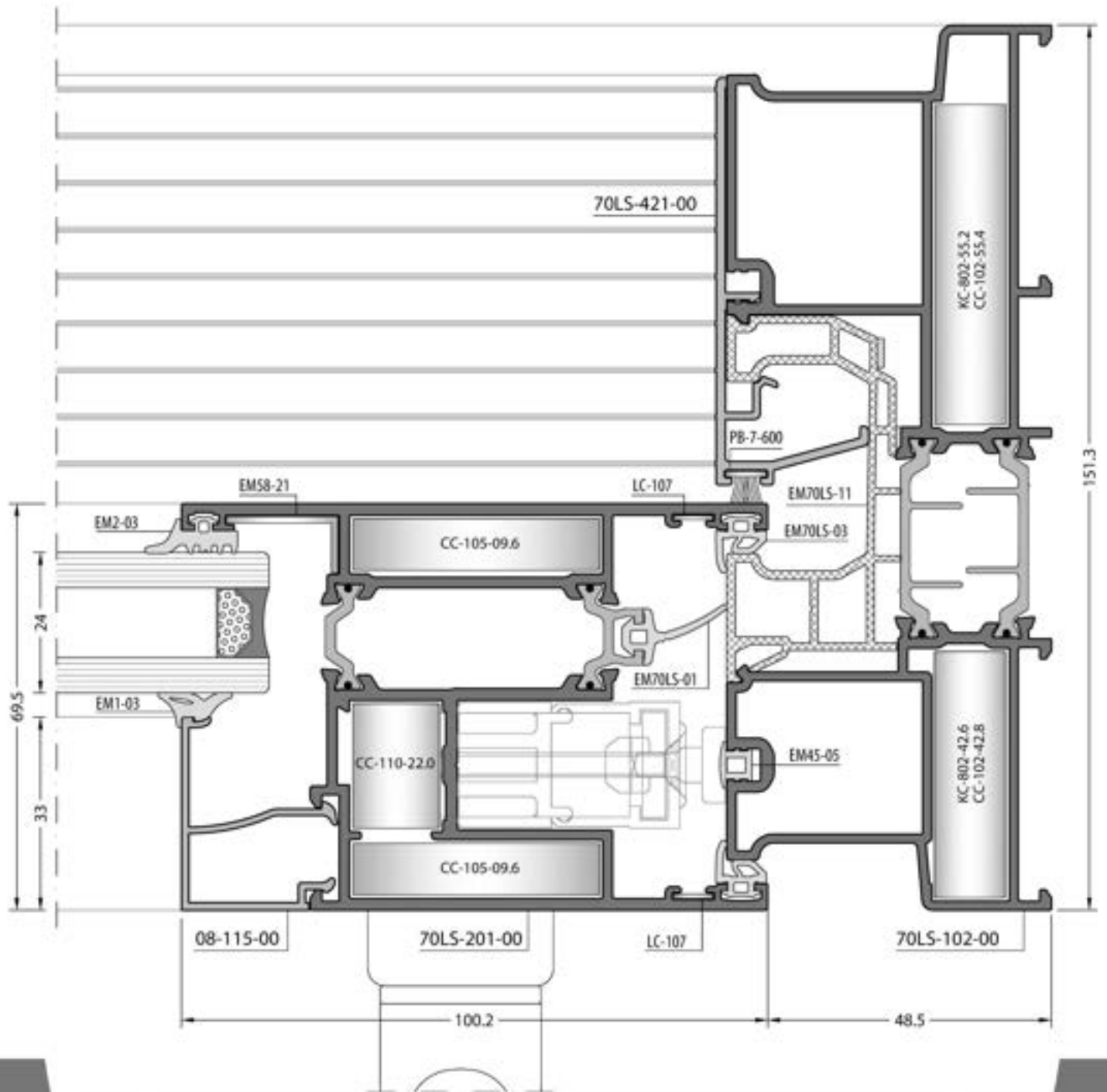
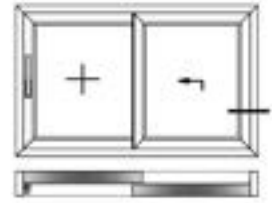

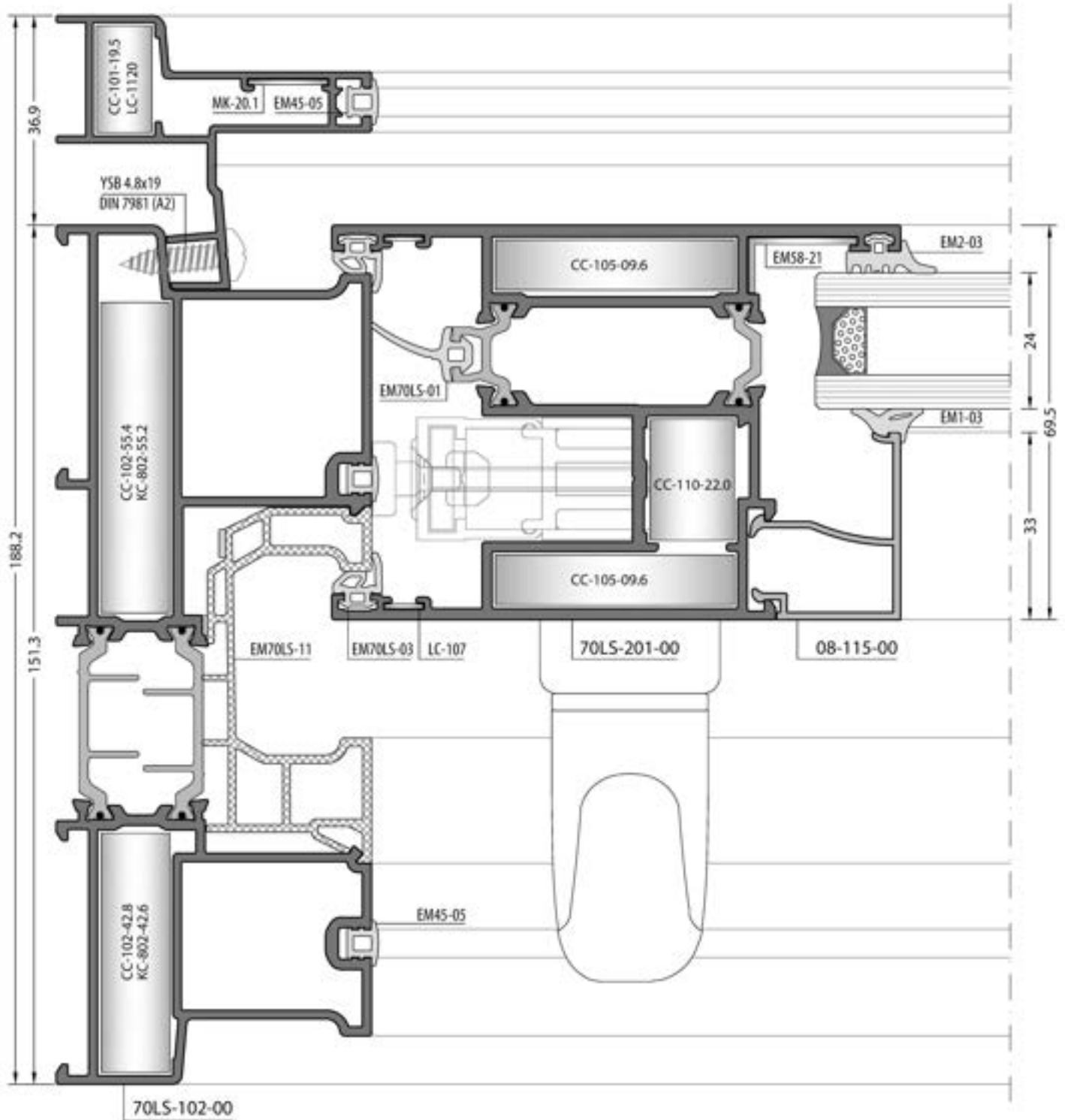
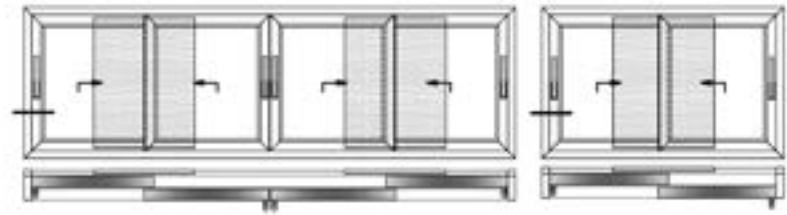

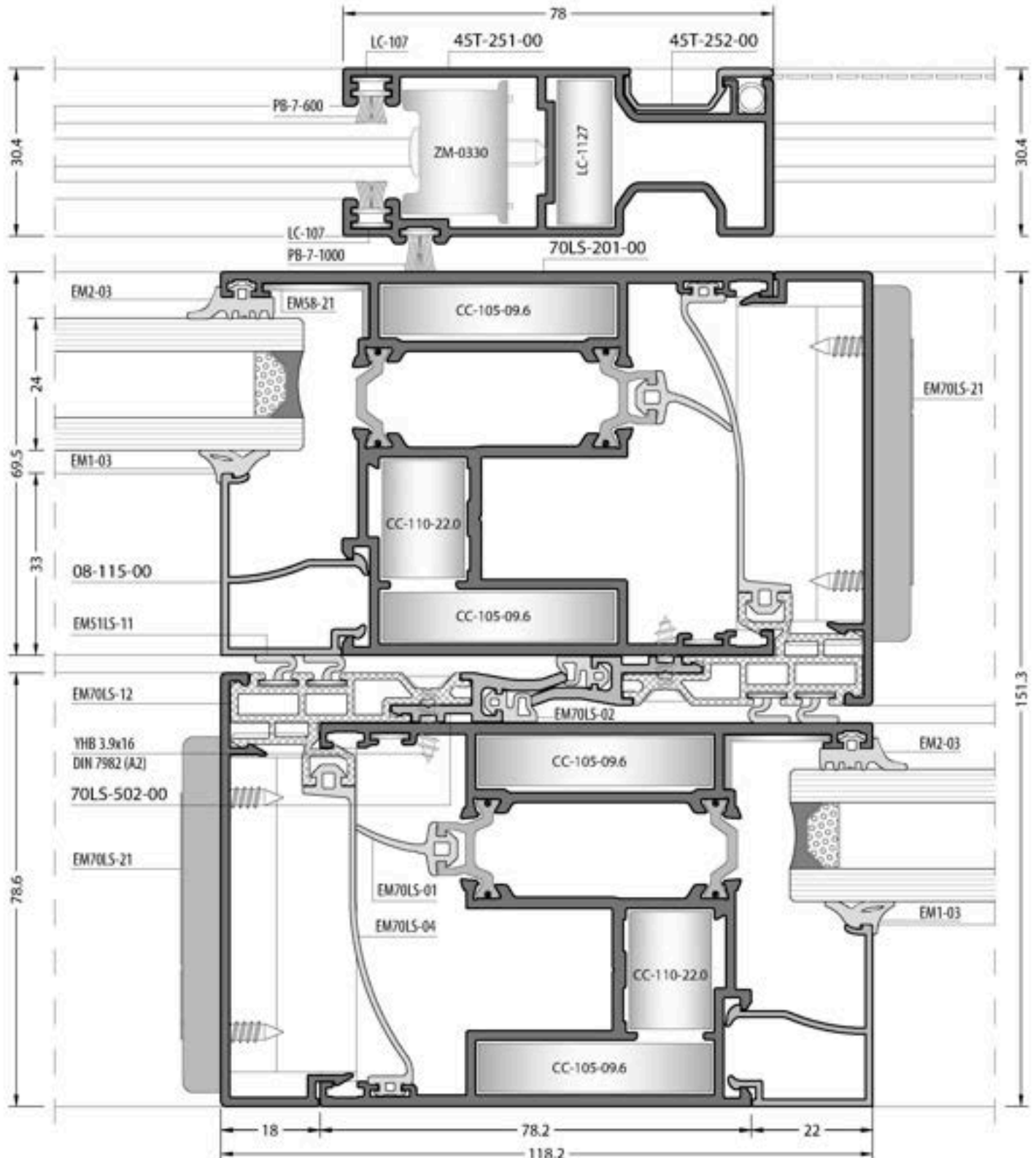
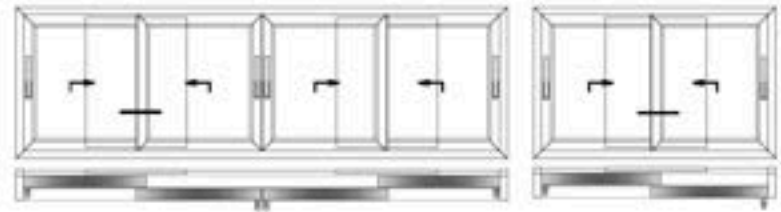

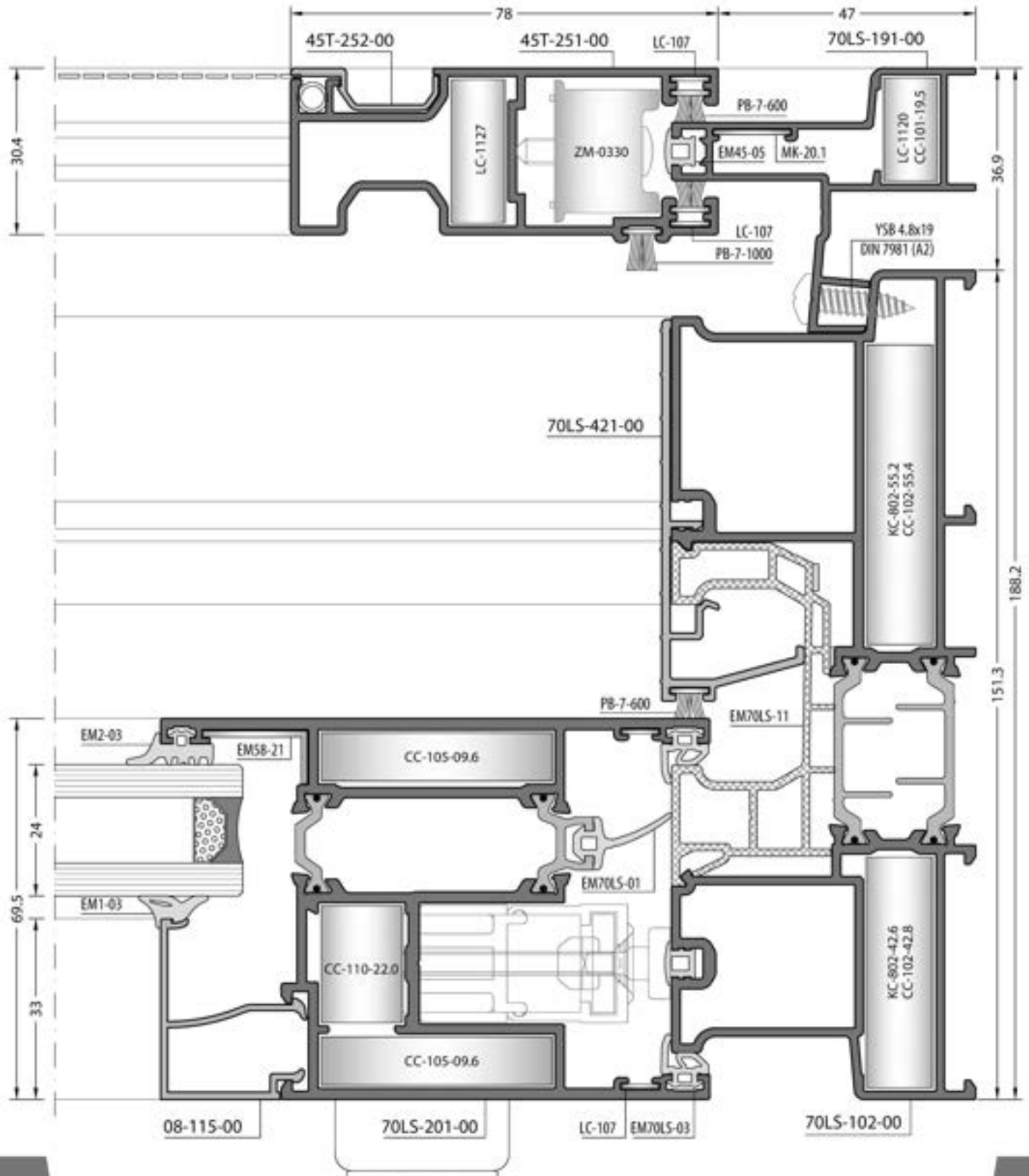
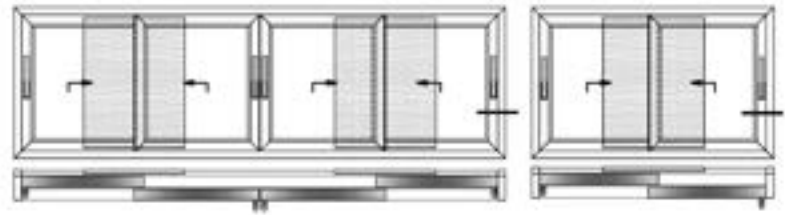

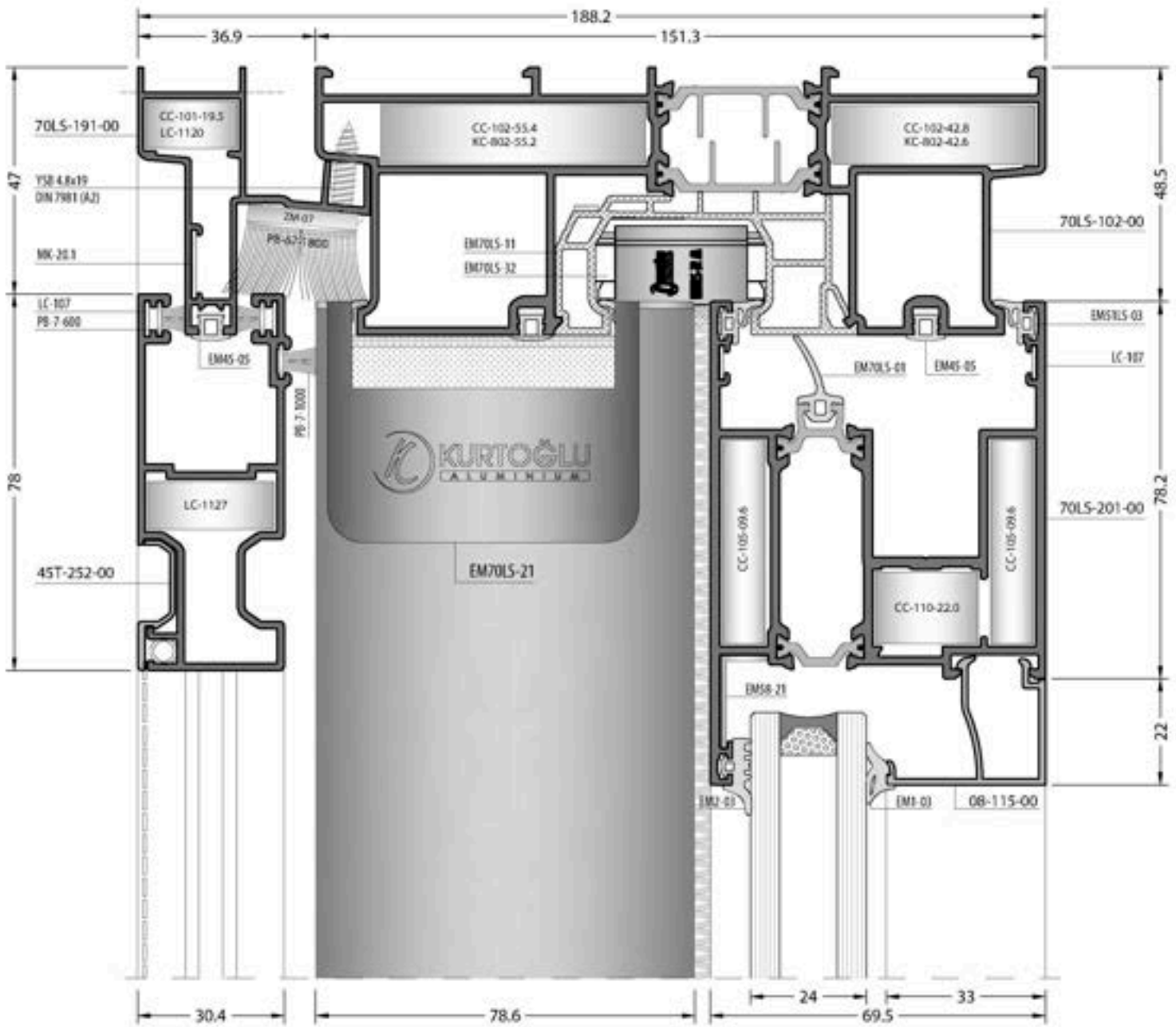
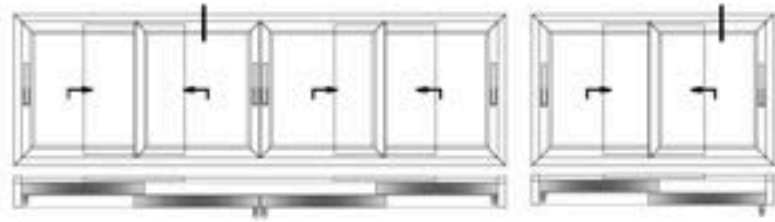

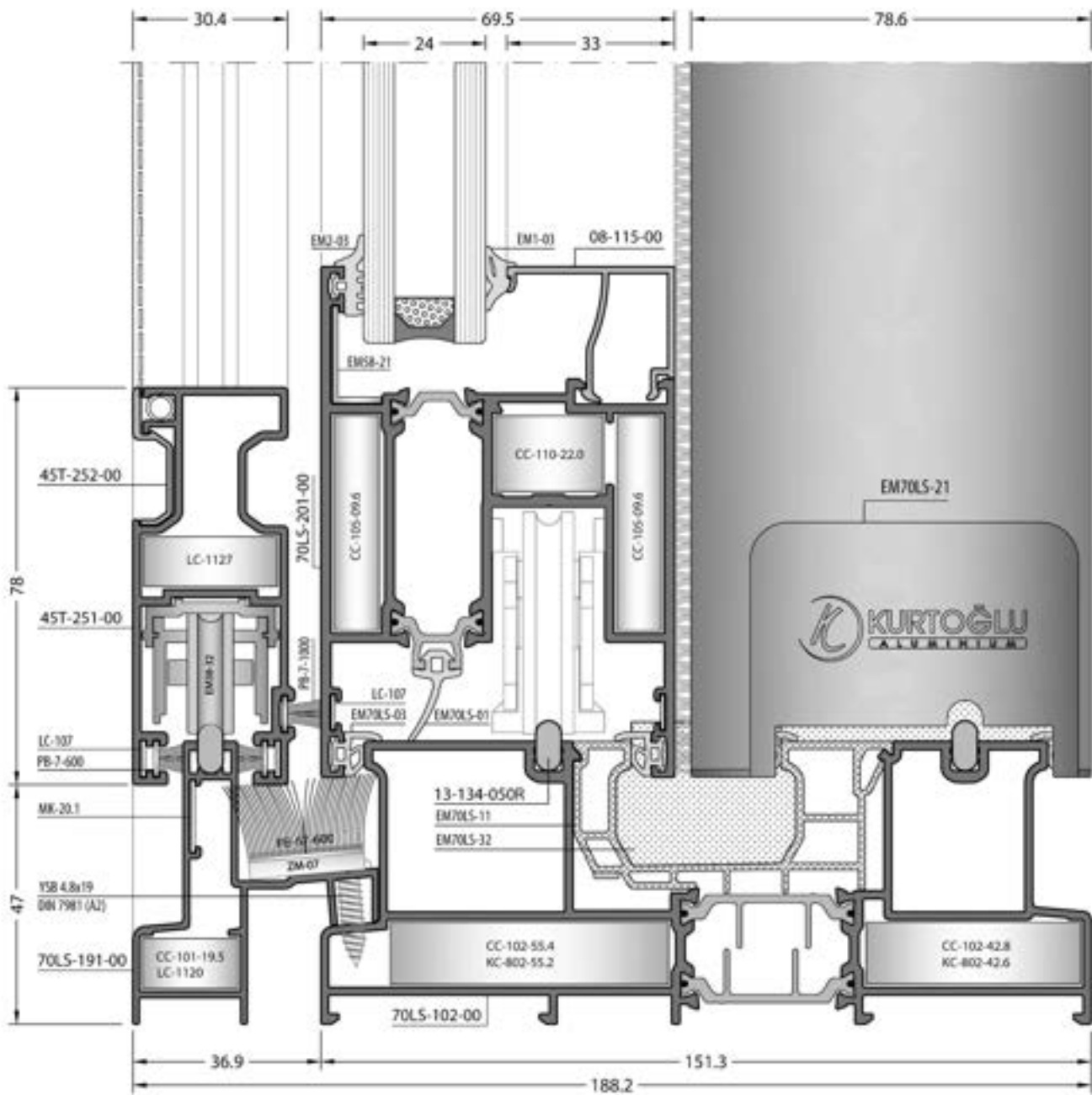
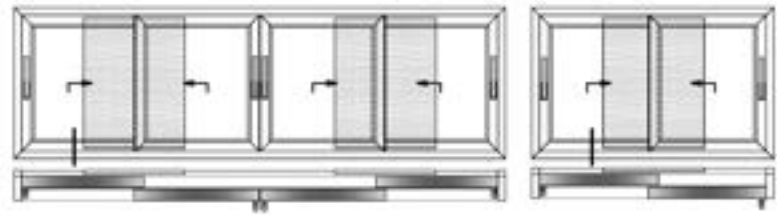

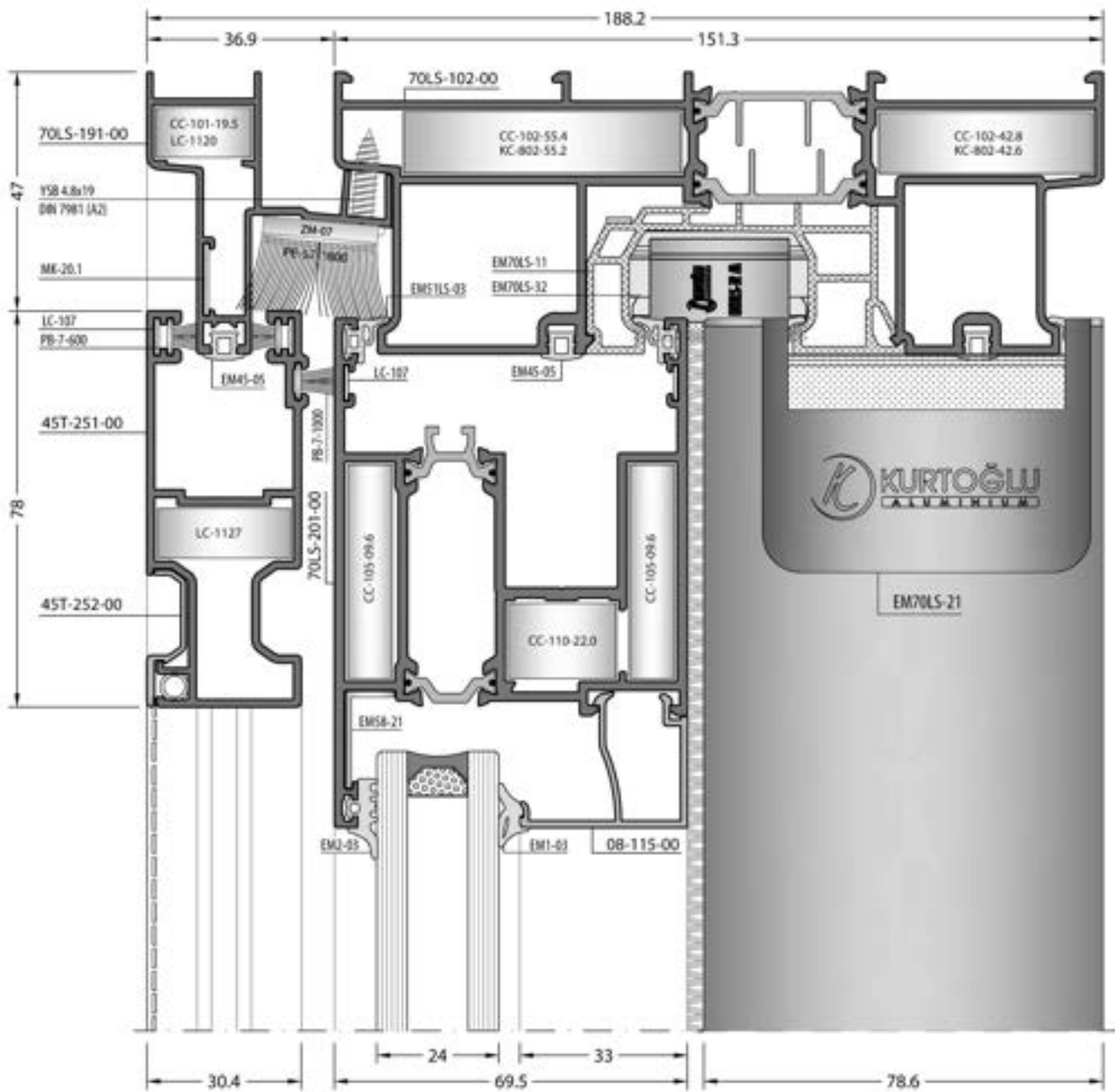
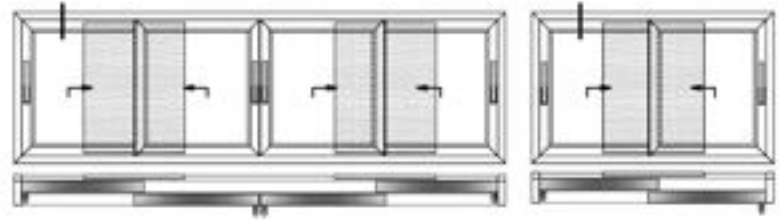

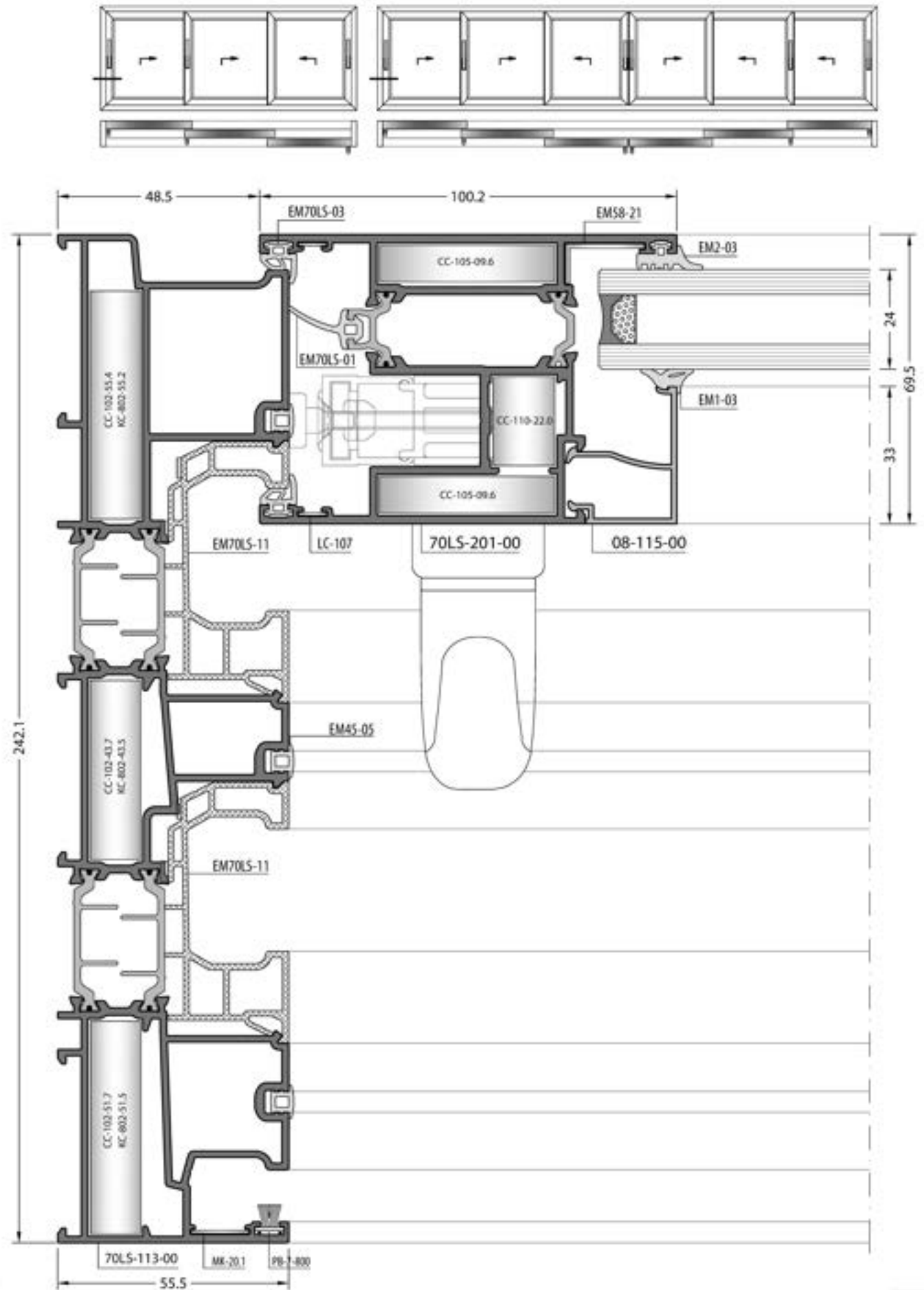

No Scaled / Ölçeksiz

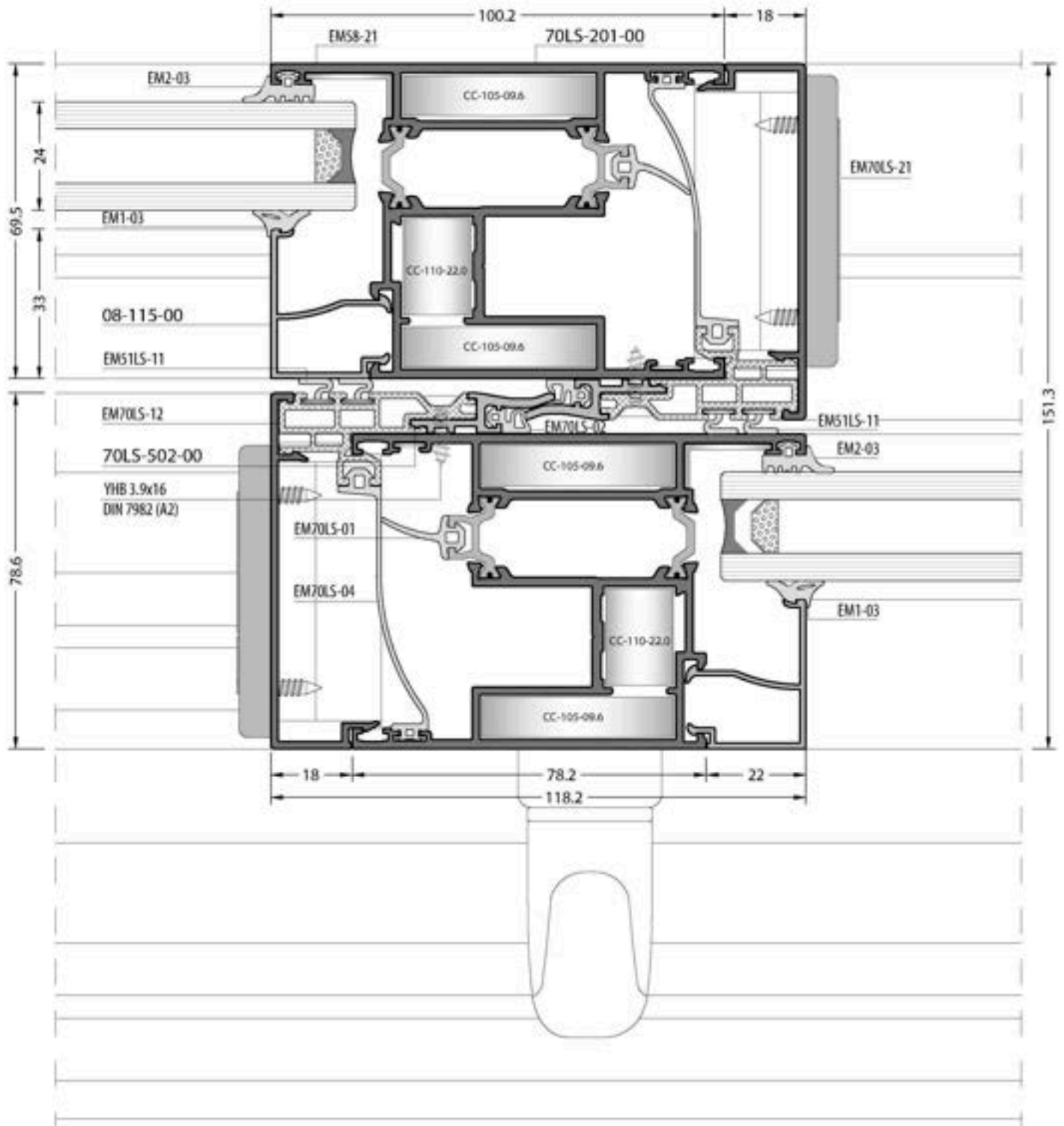
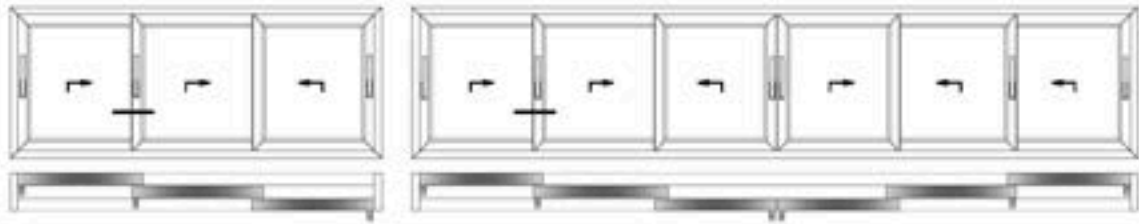

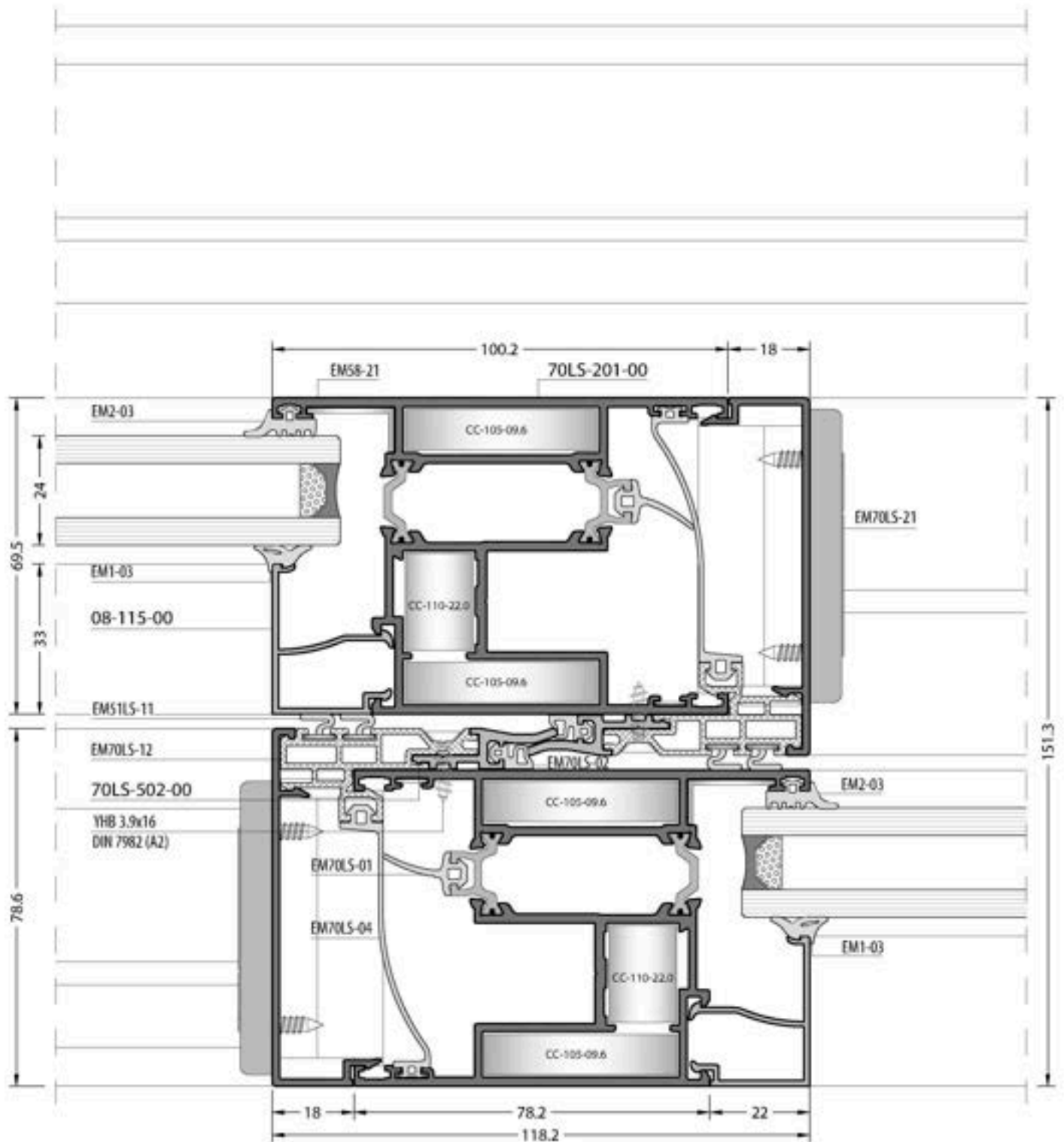
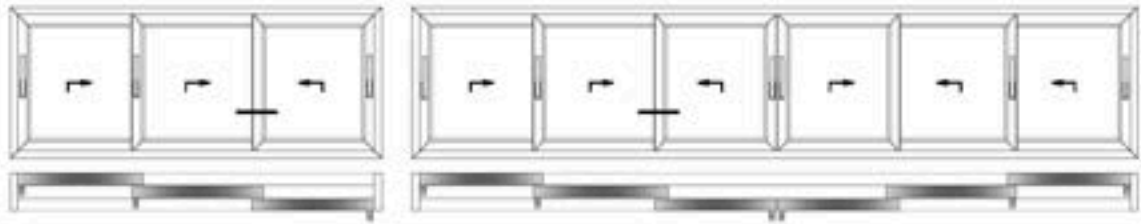

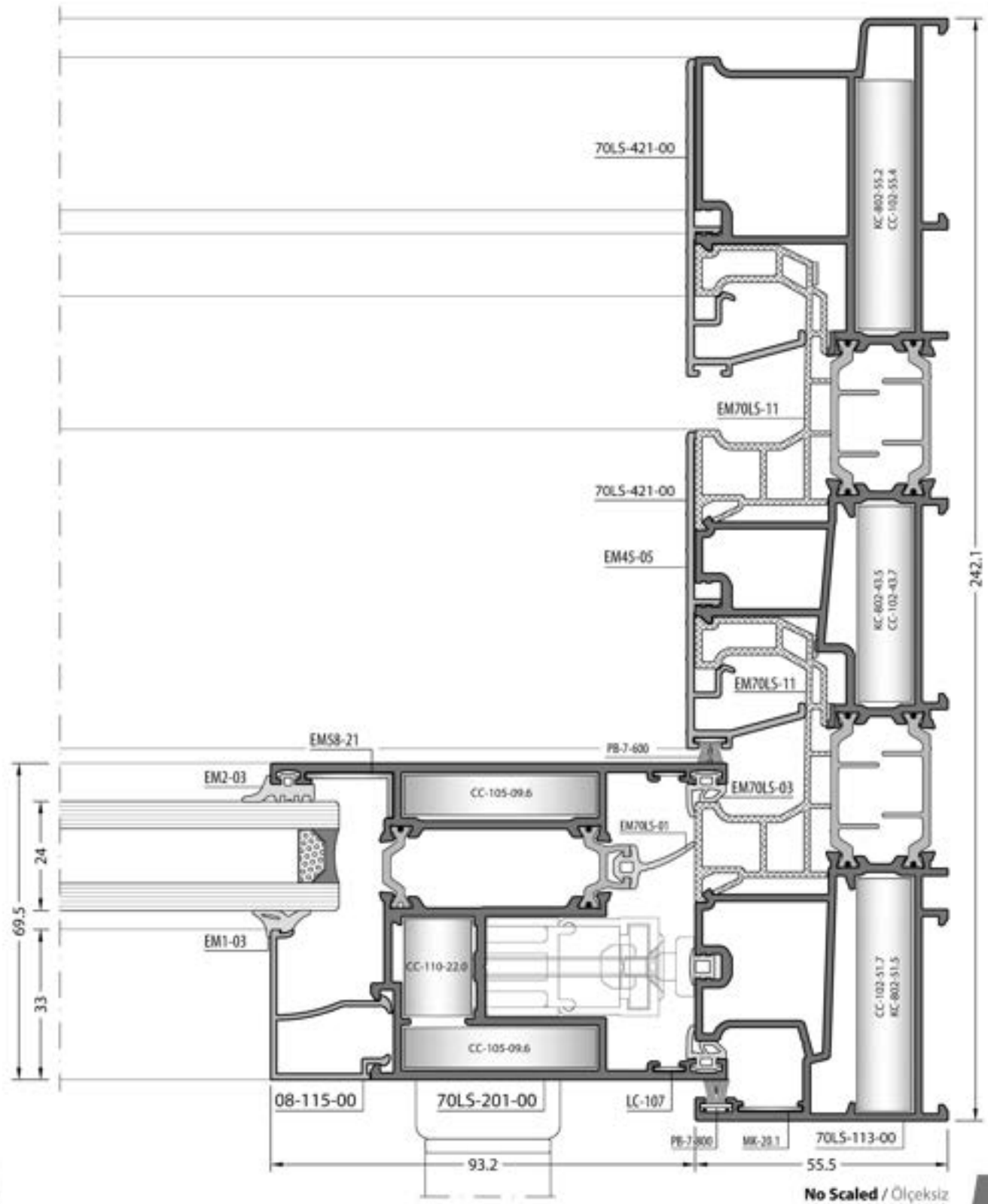
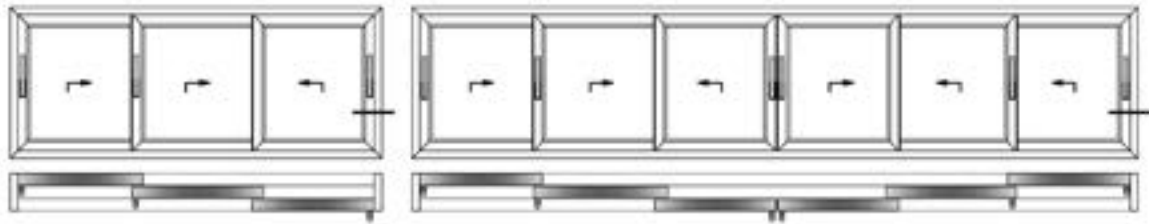

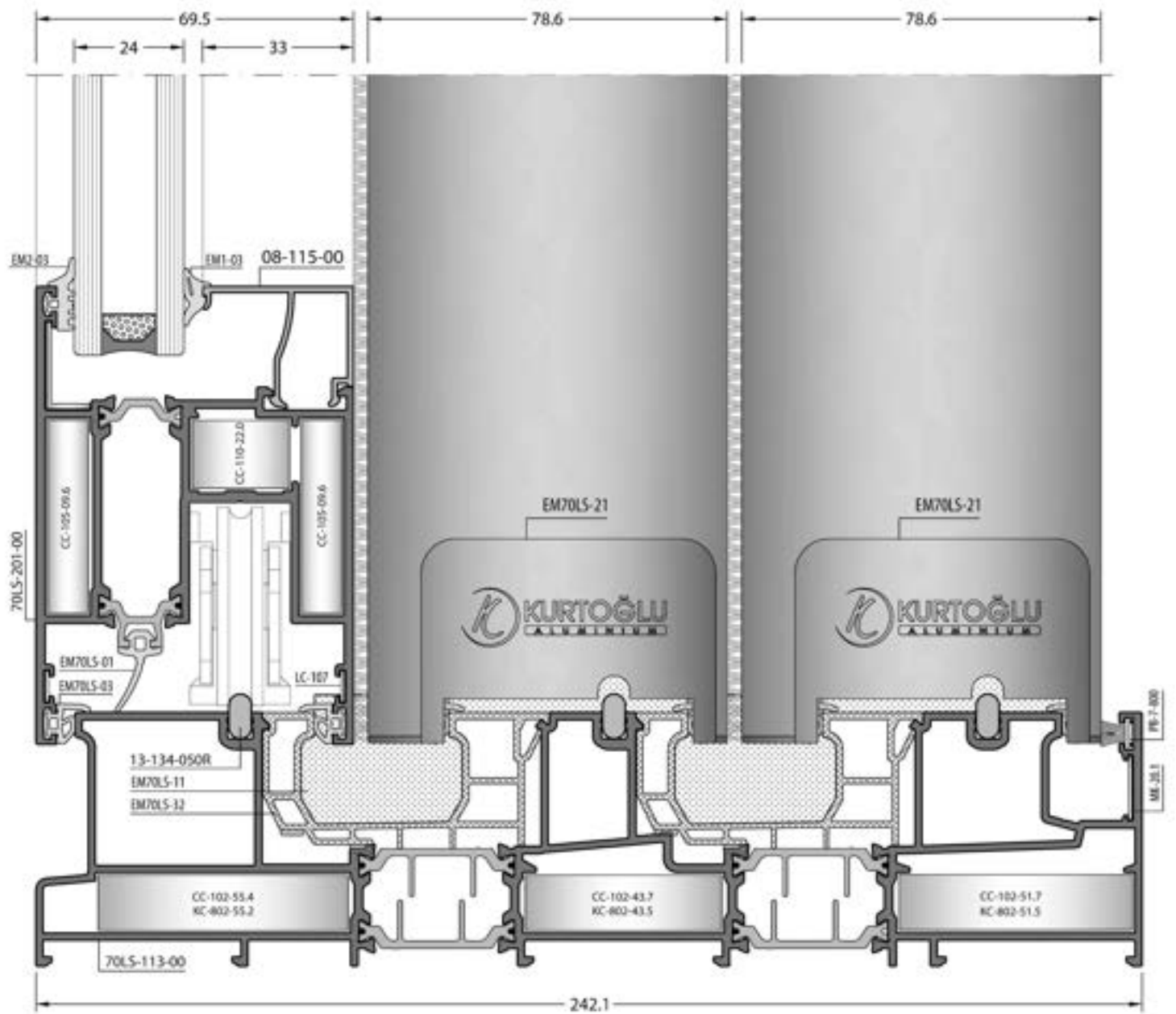
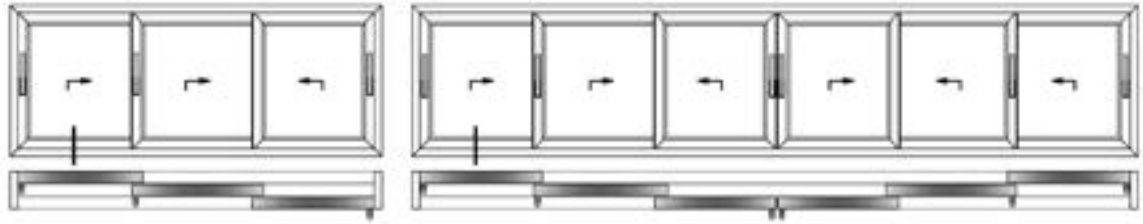

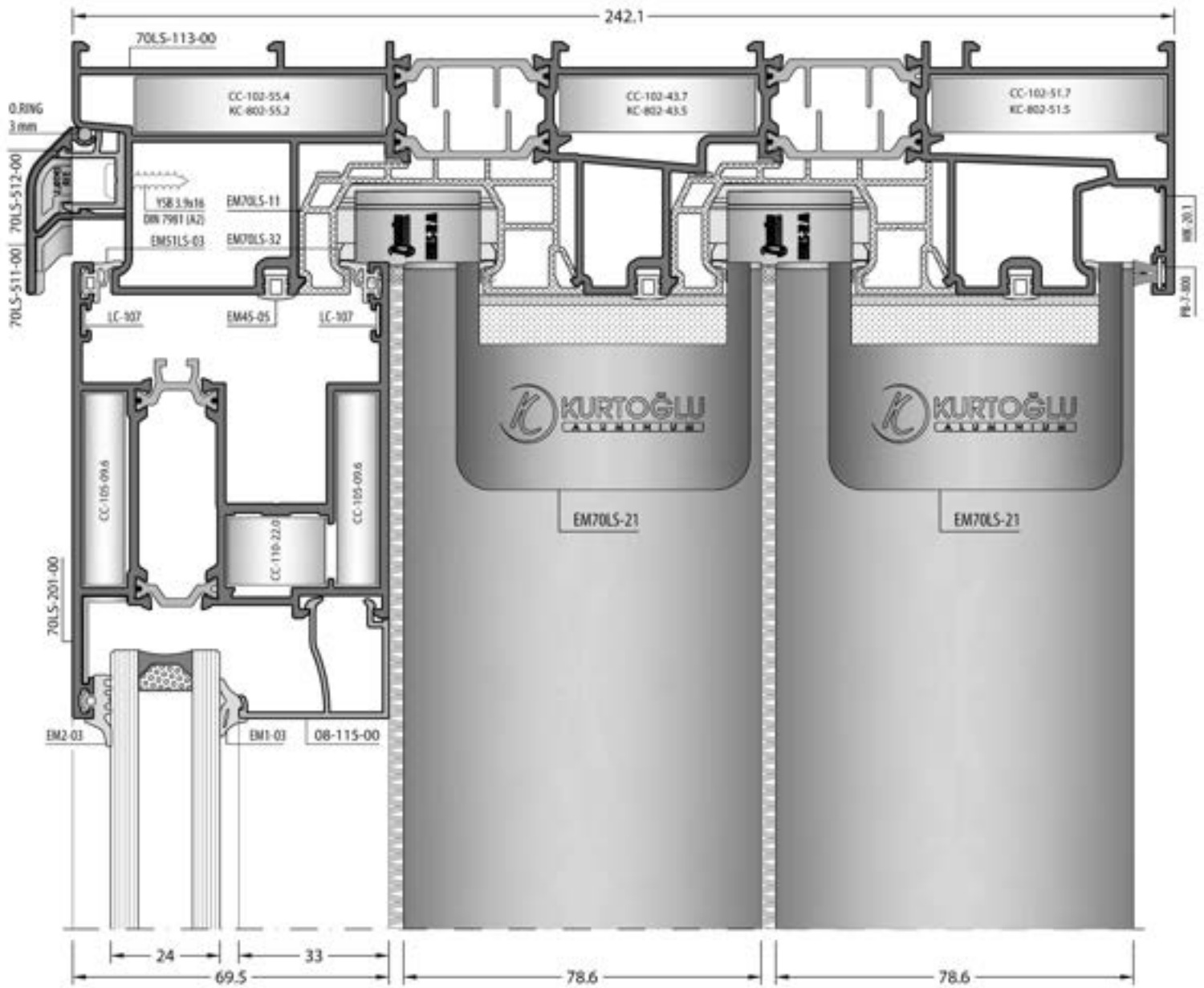
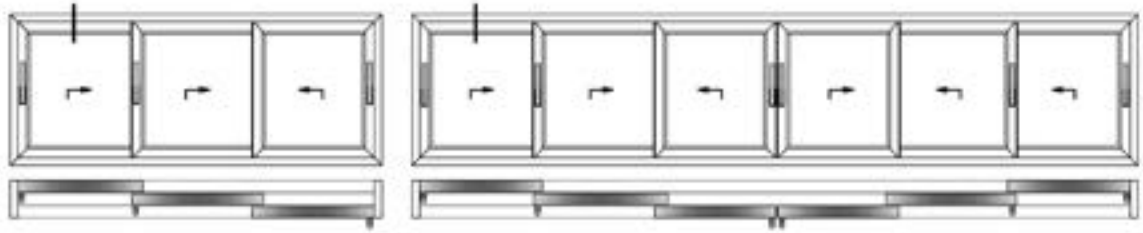

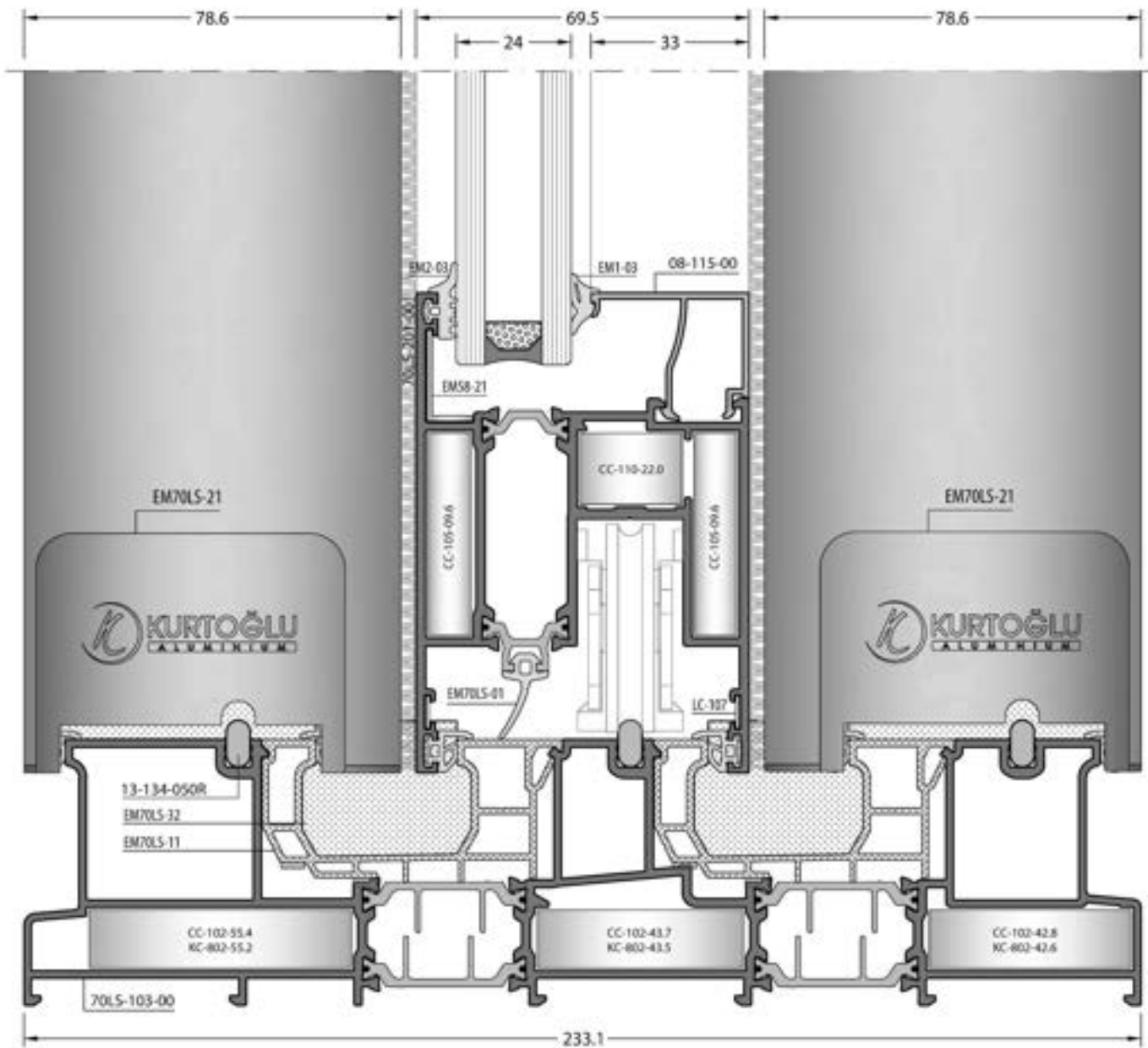
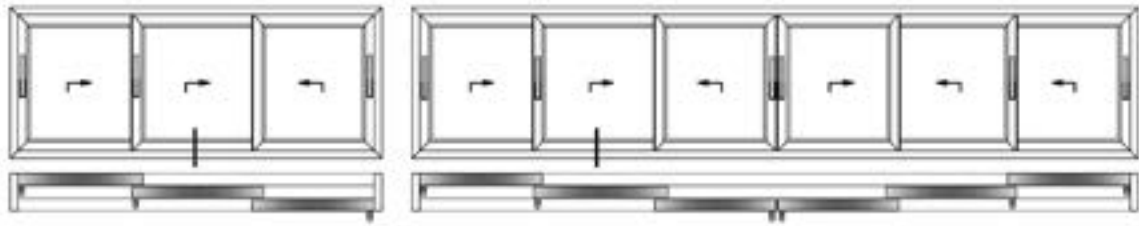

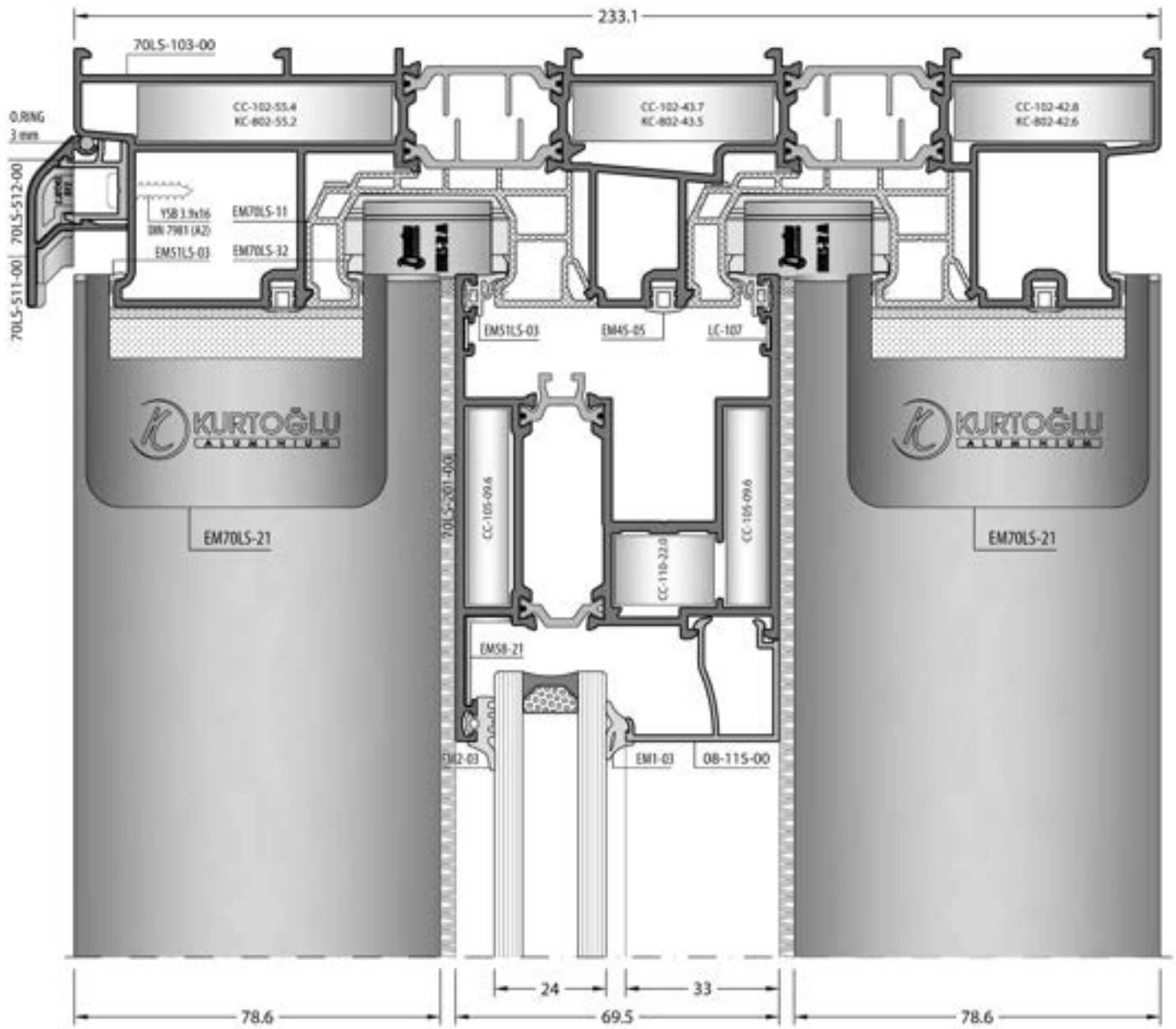
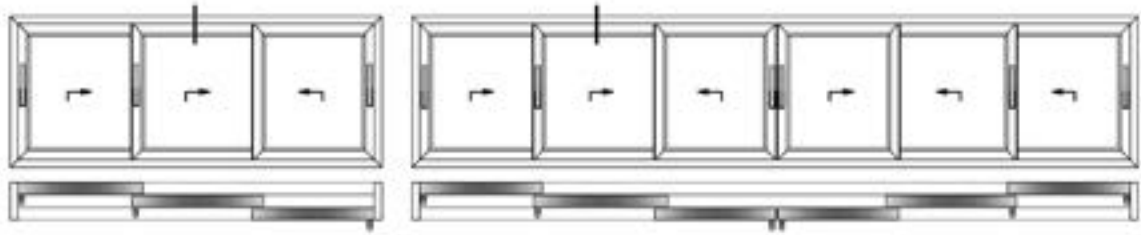

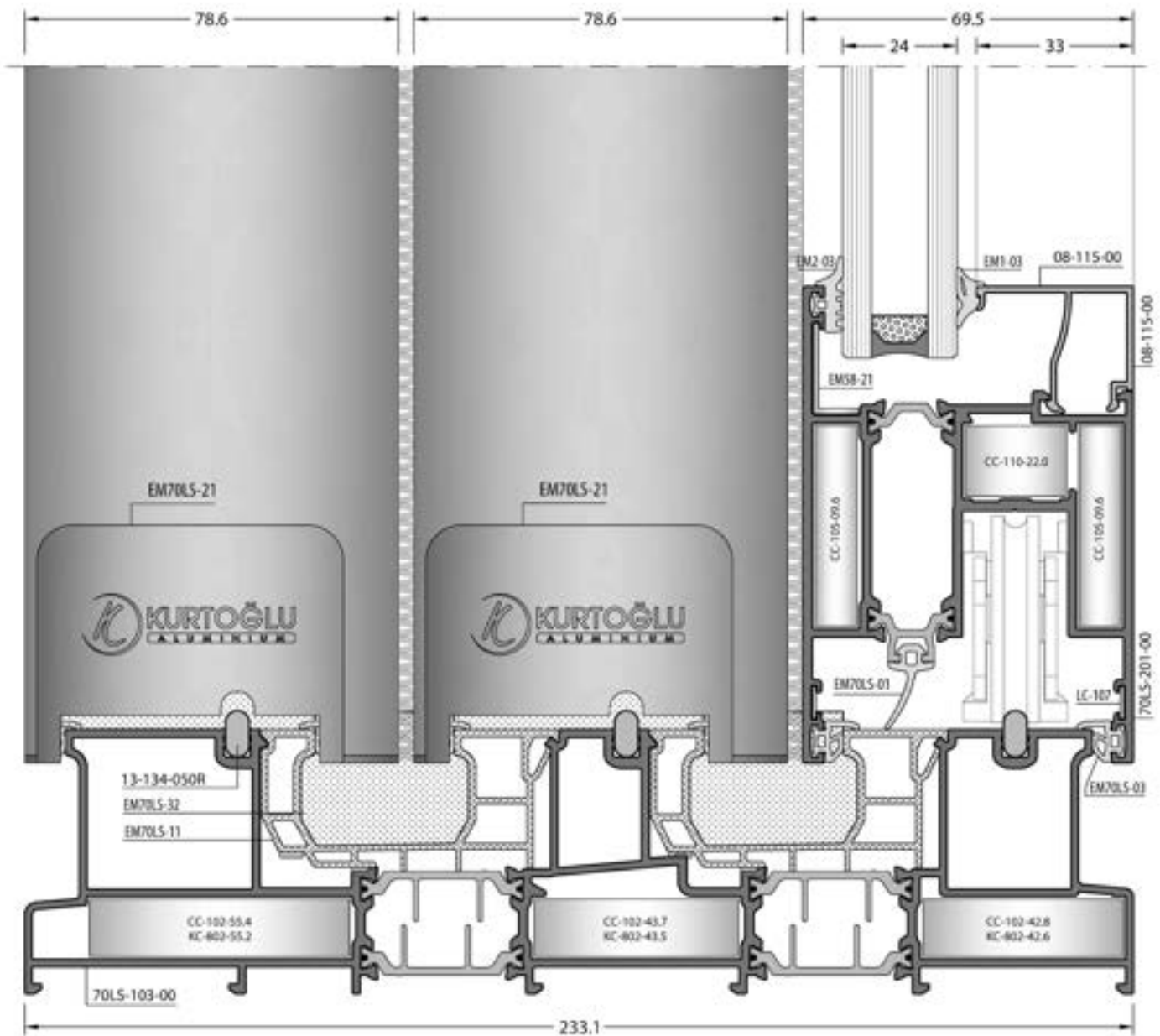
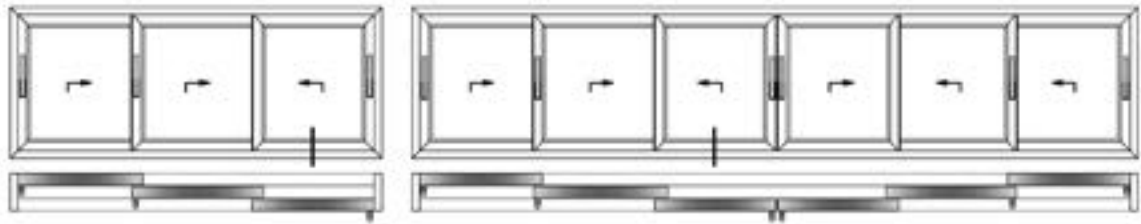

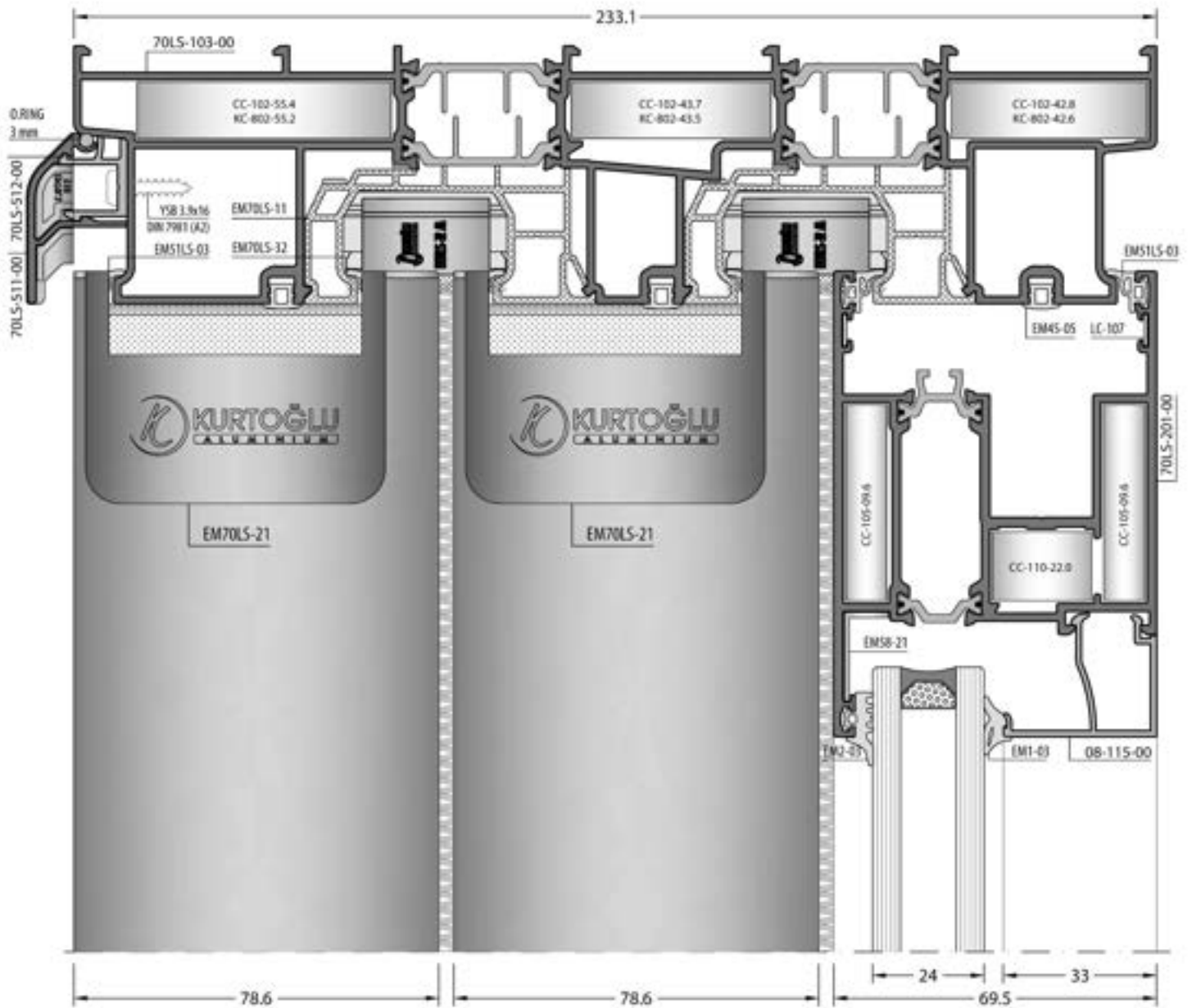
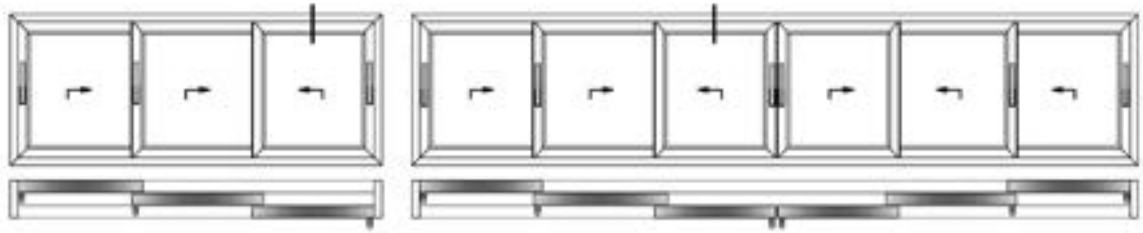

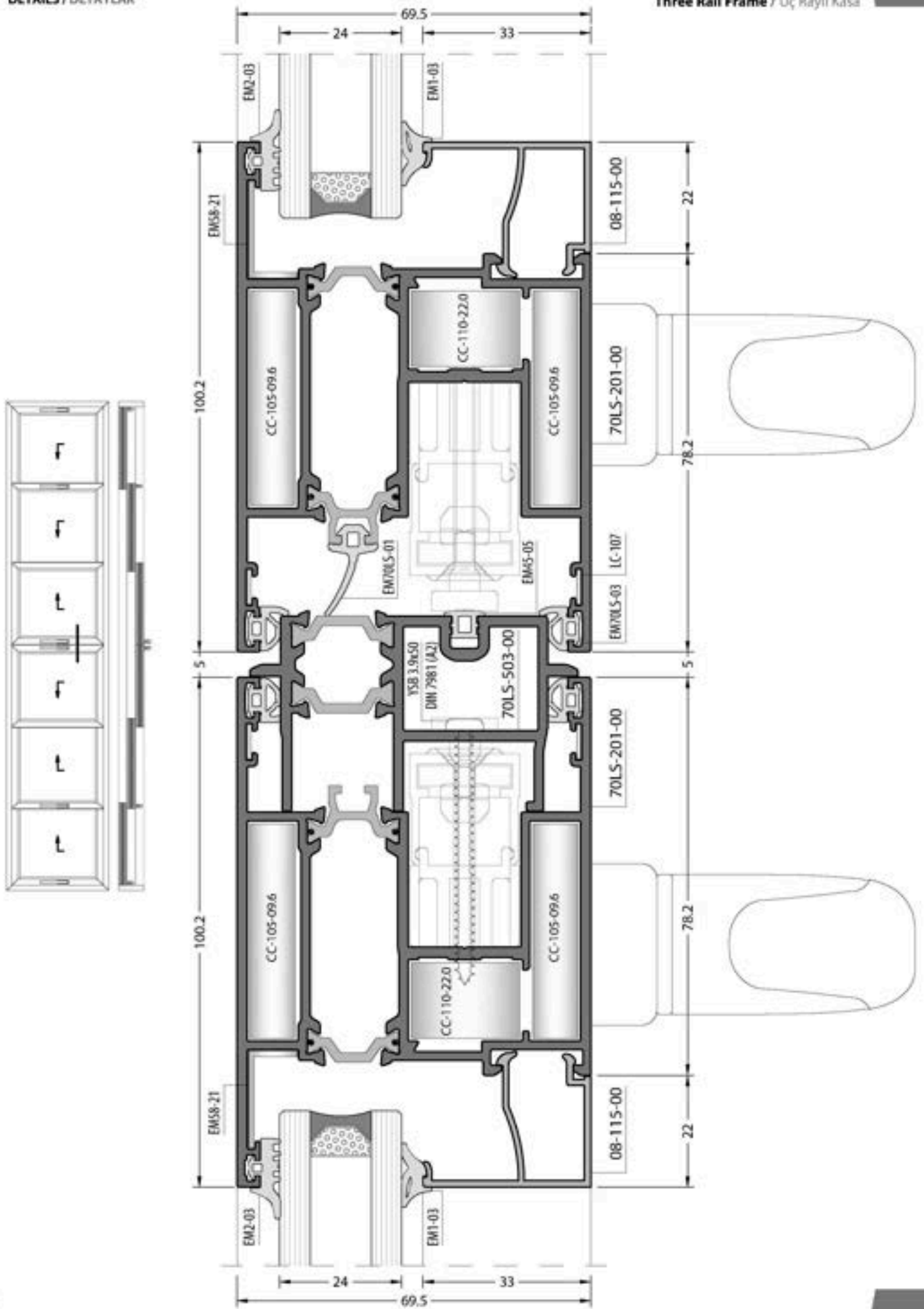

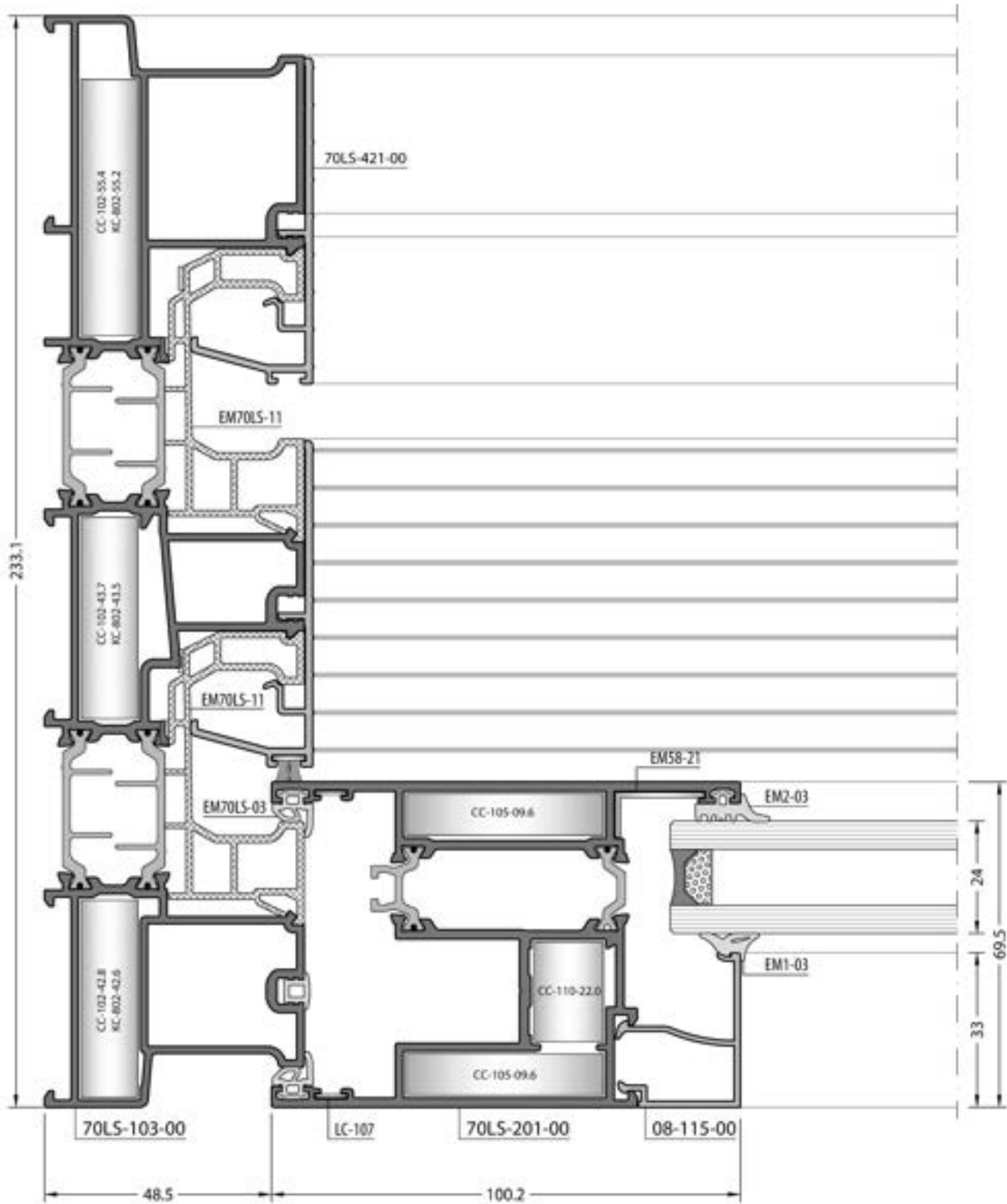
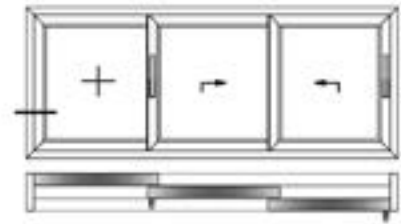

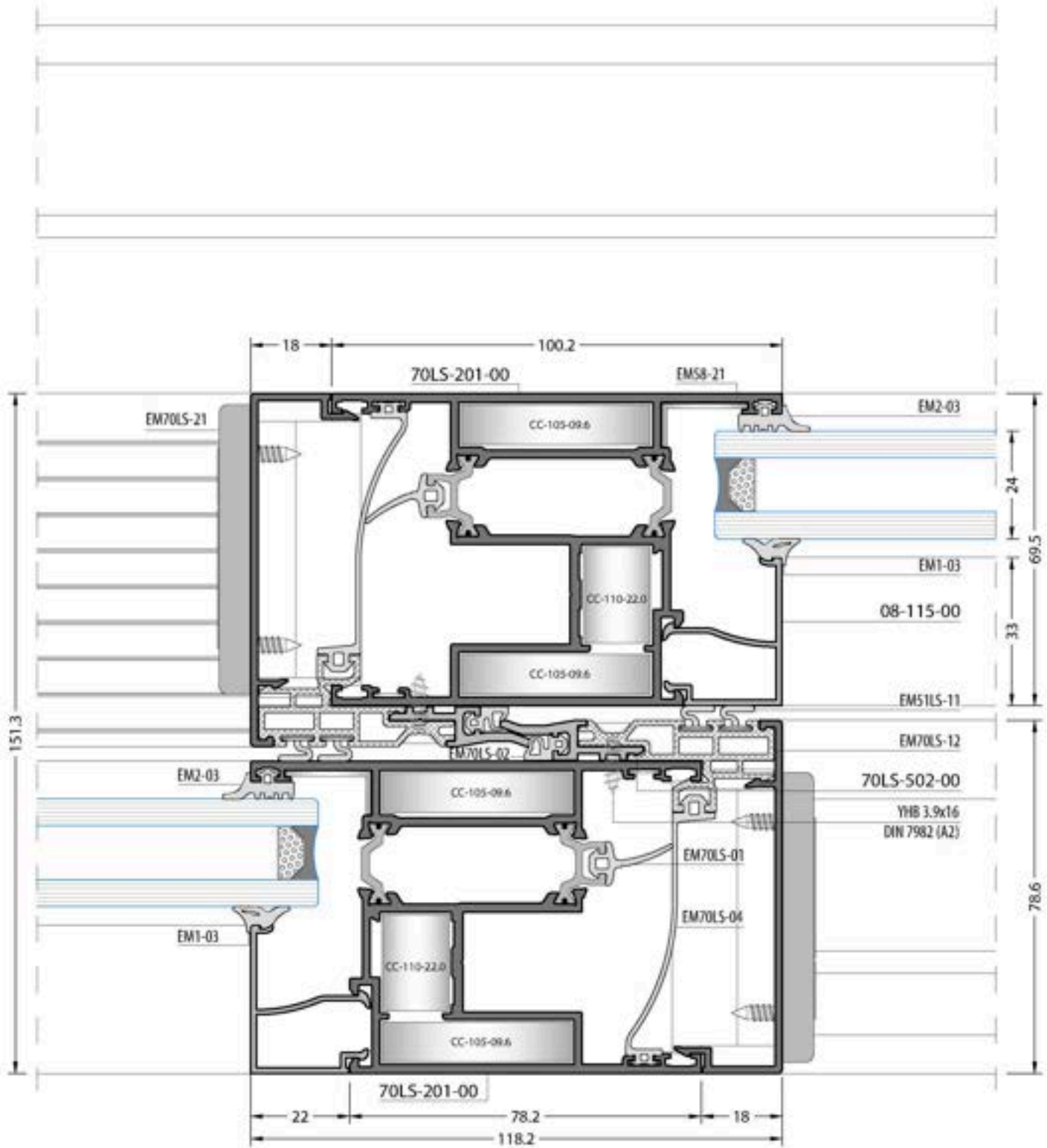
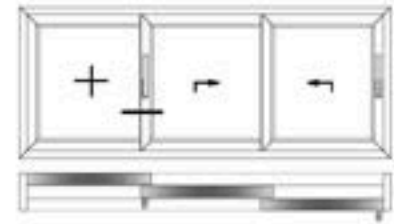

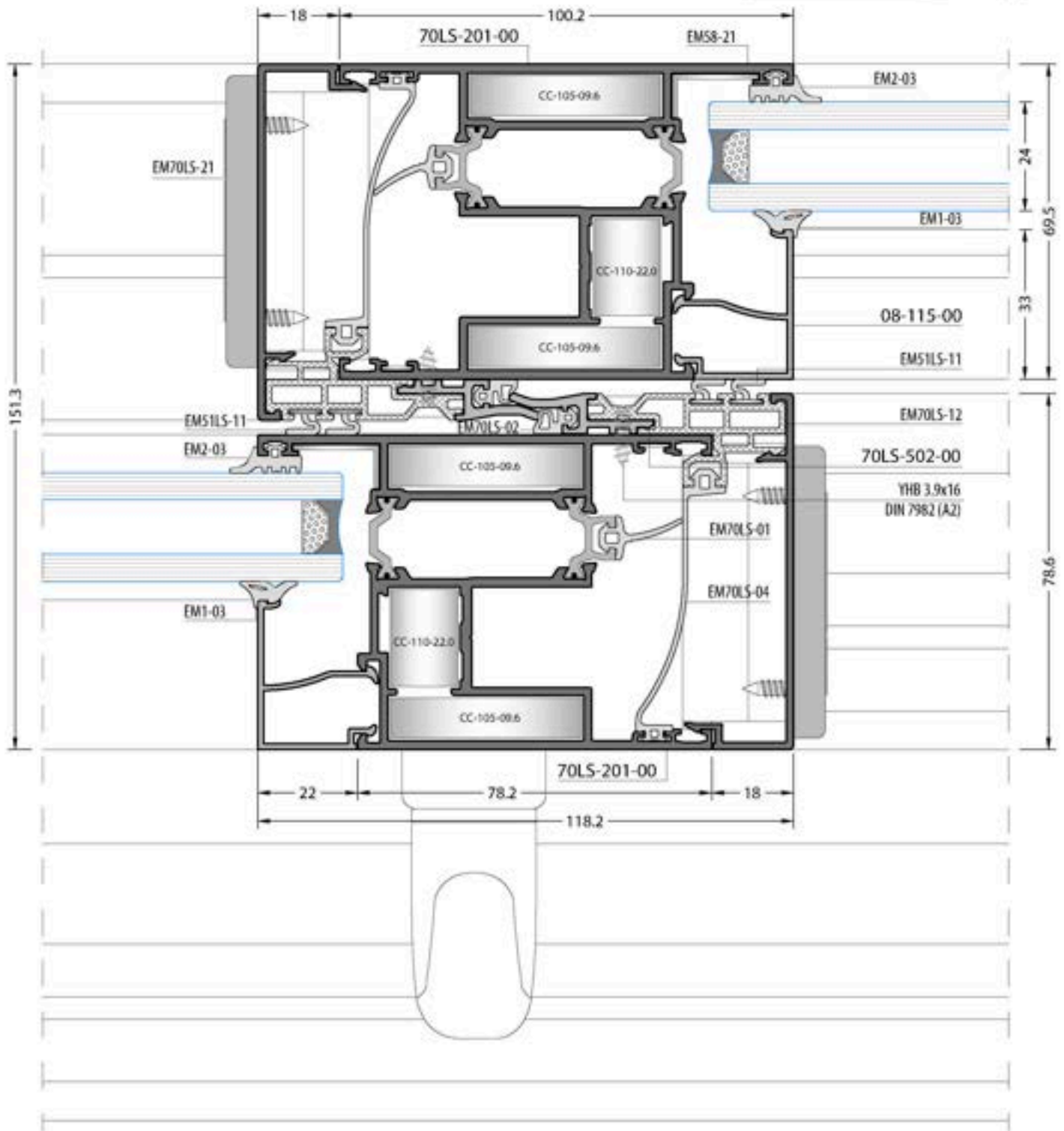
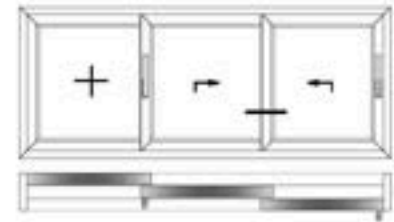

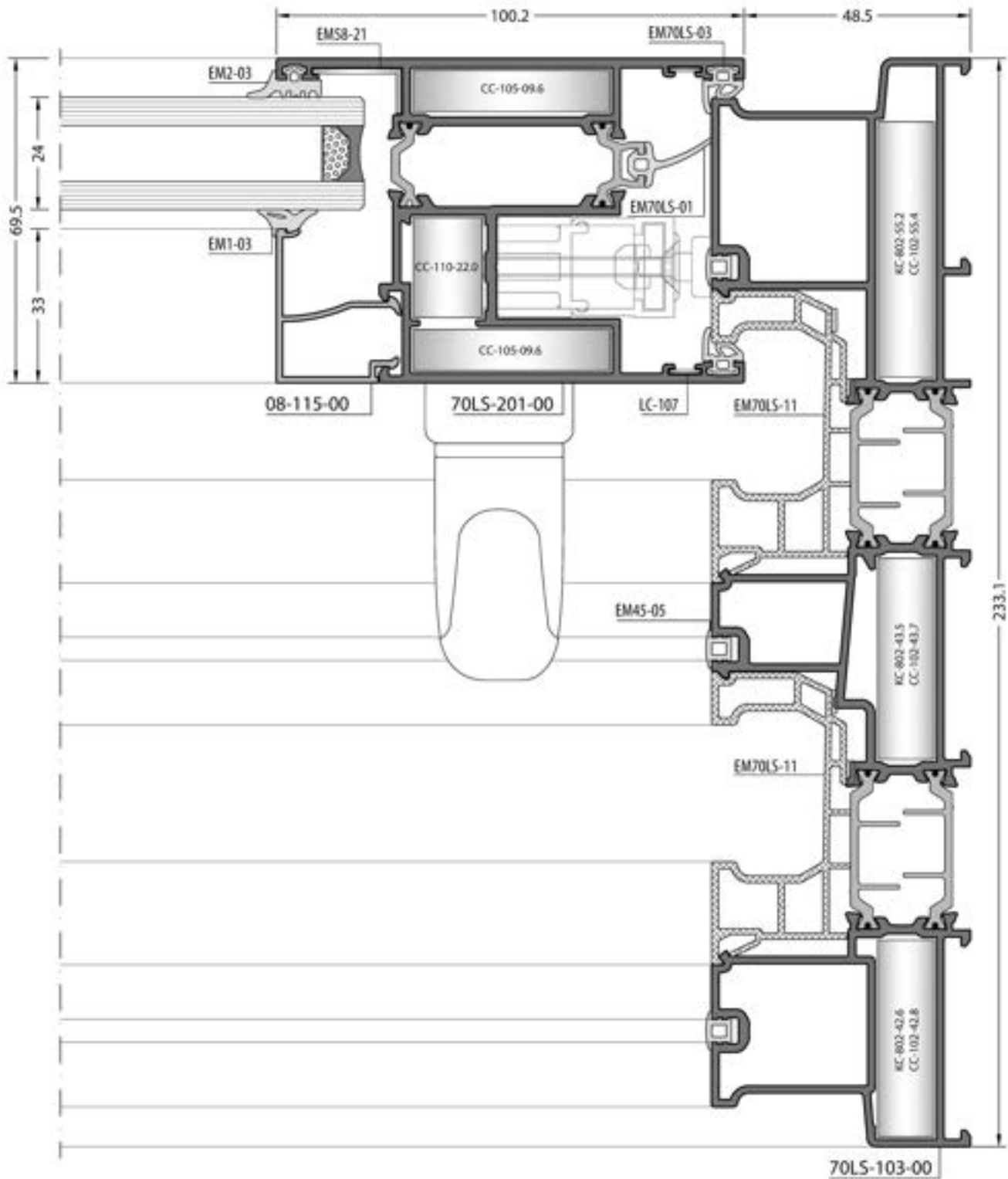
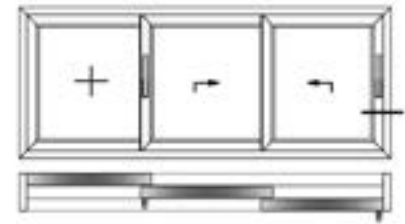

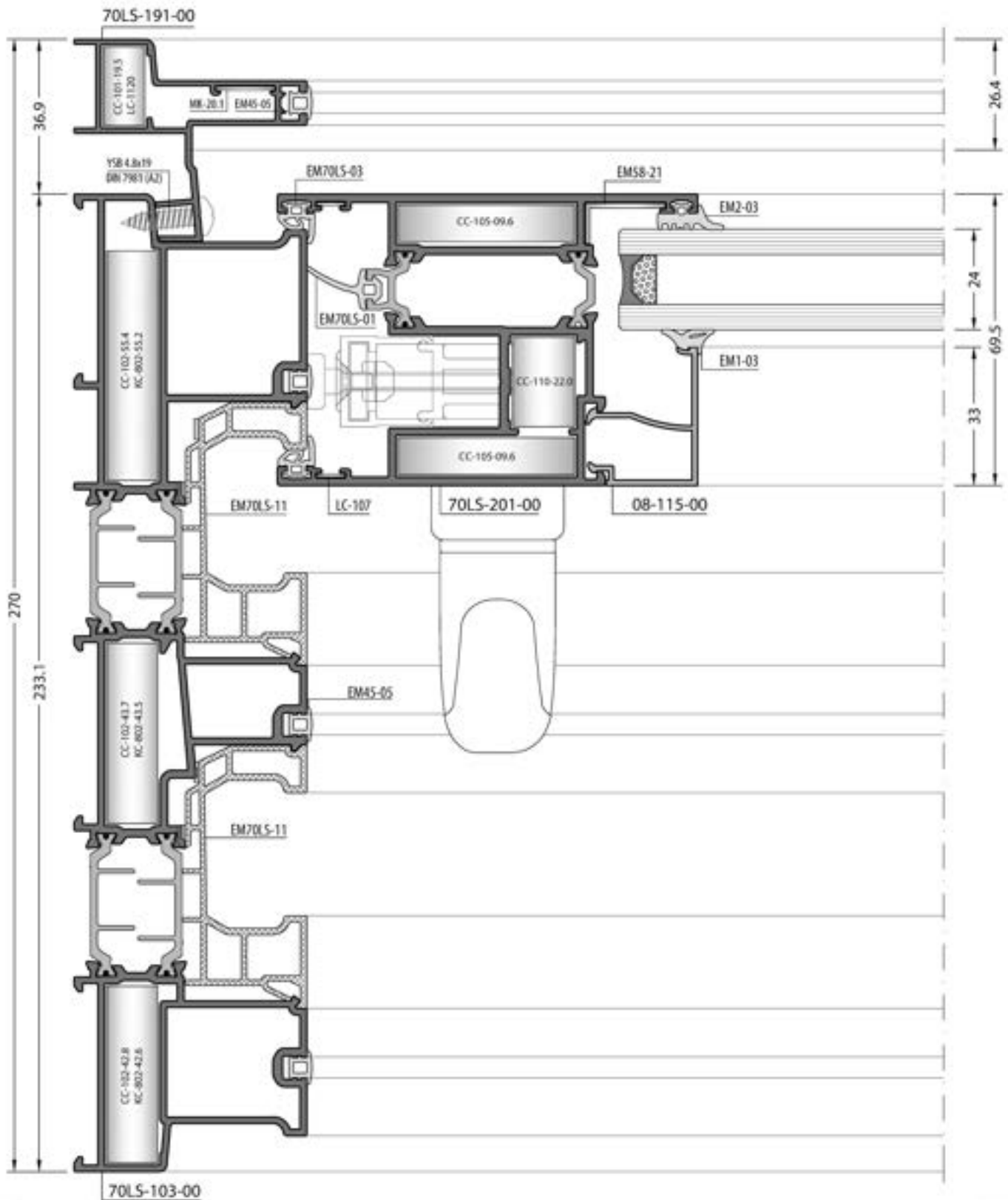
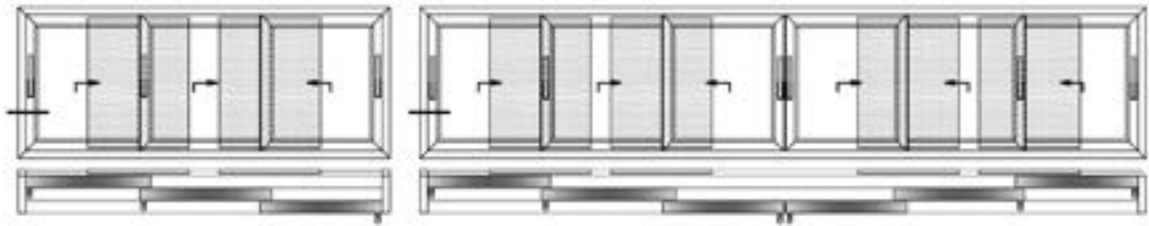

No Scaled / Ölçeksiz

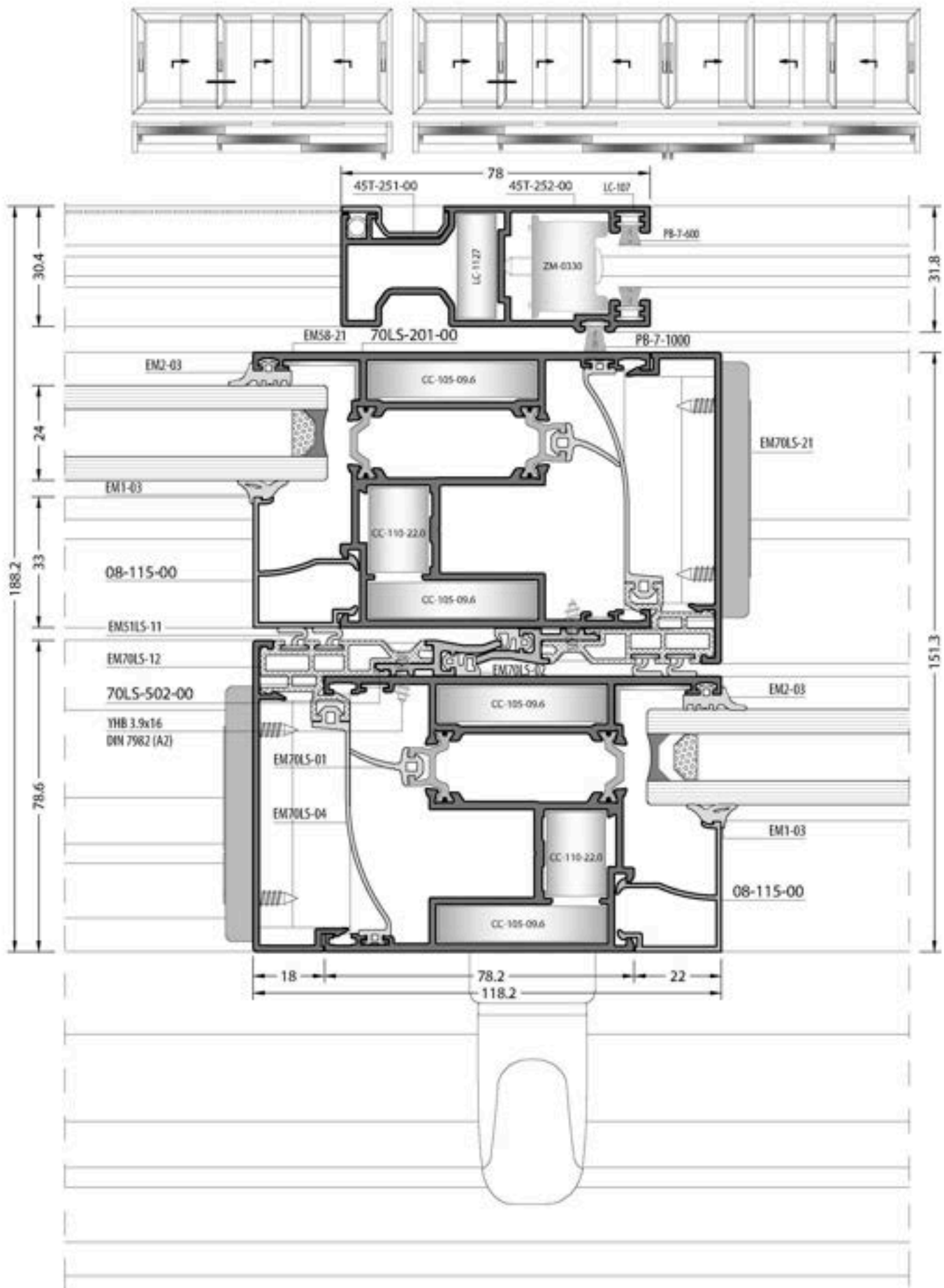

No Scaled / Ölçeksiz

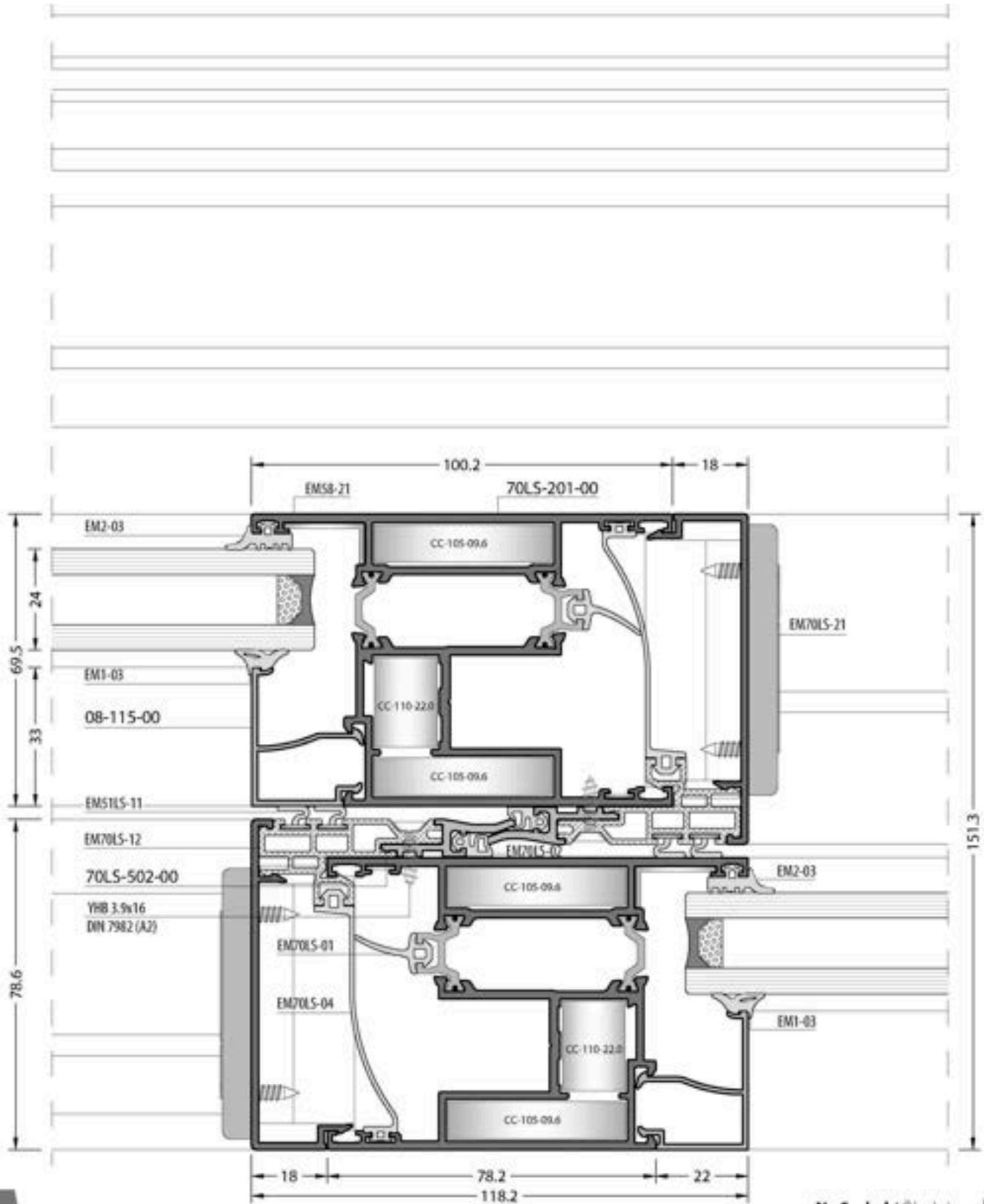
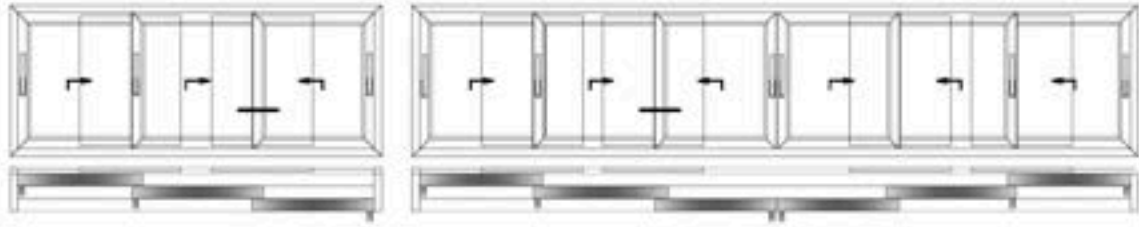

No Scaled / Ölçeksiz

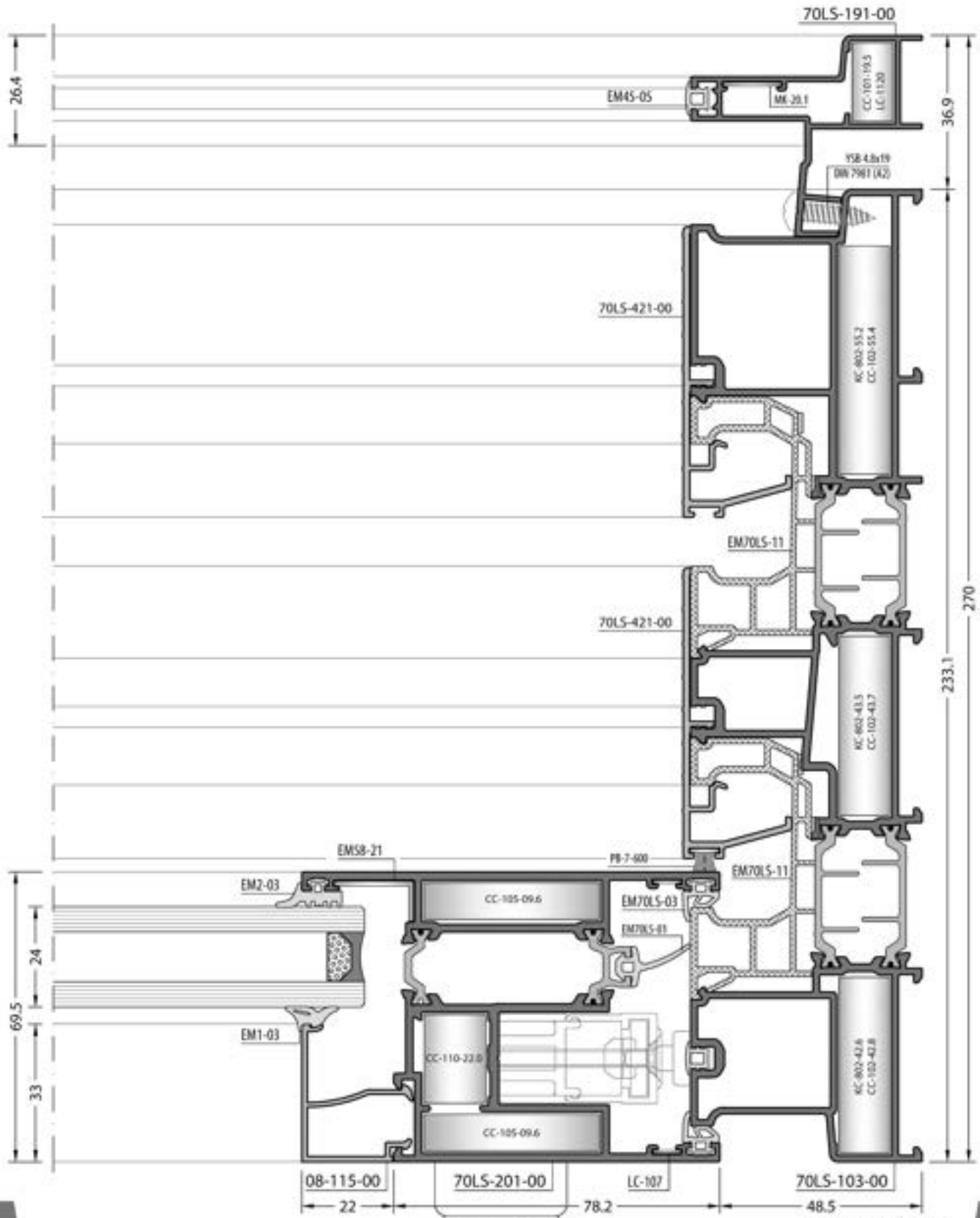
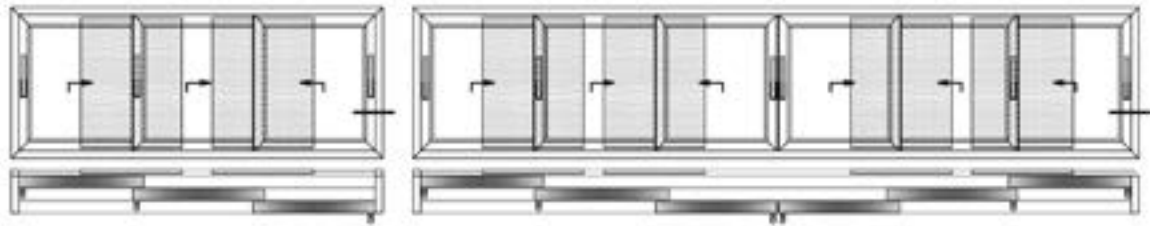

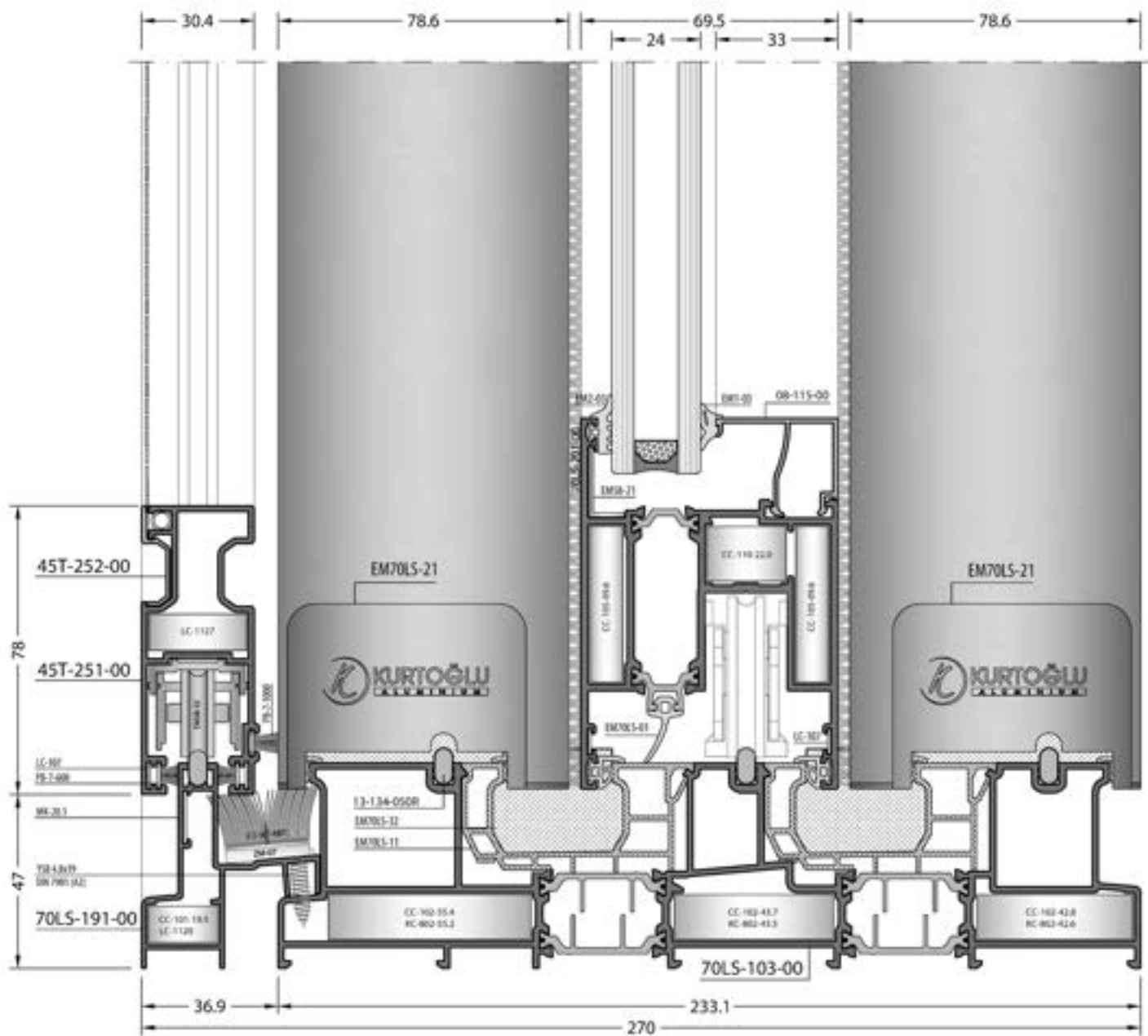
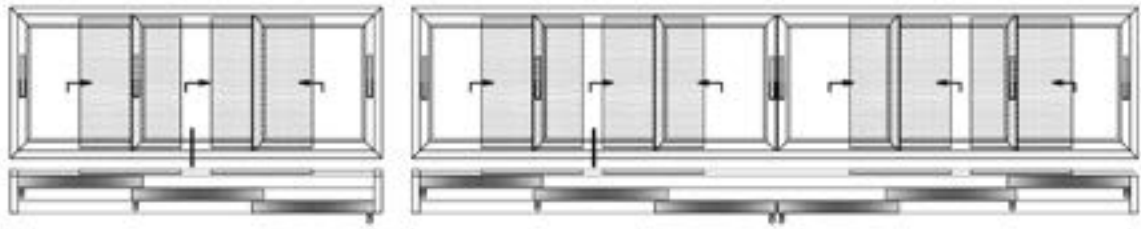

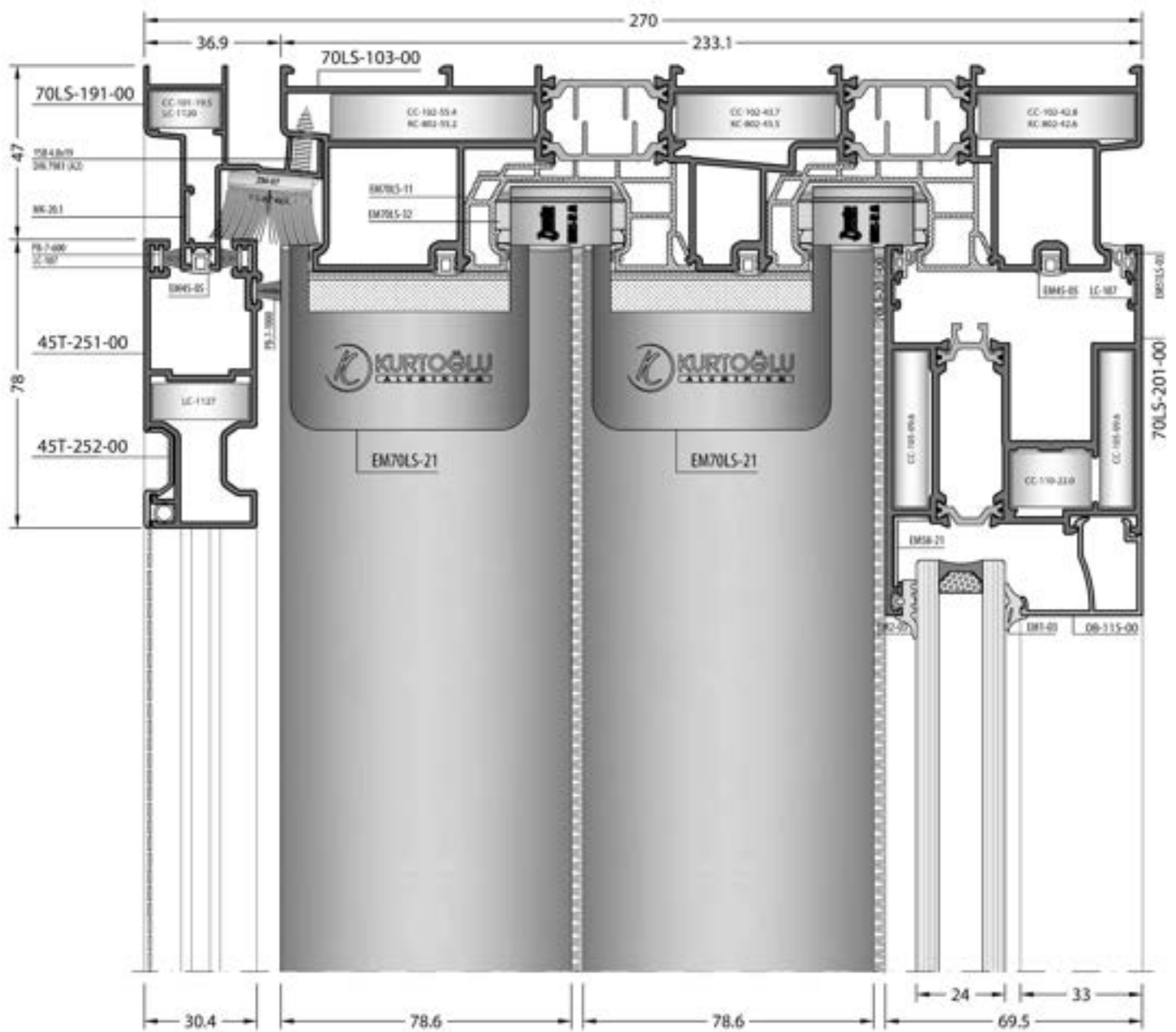
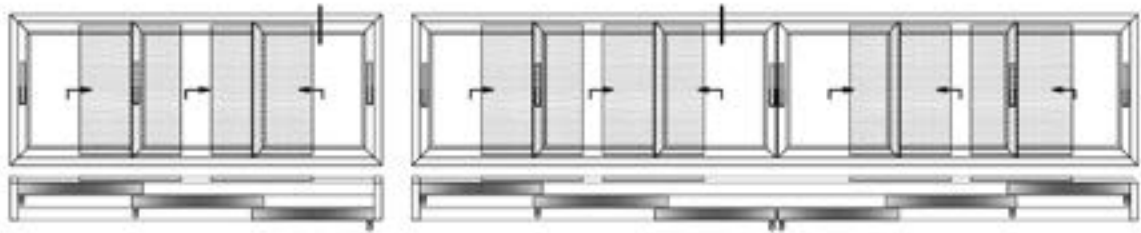

GLAZING TABLES
CAM TABLOLARI

GLAZING TABLE / CAM TABLOSU

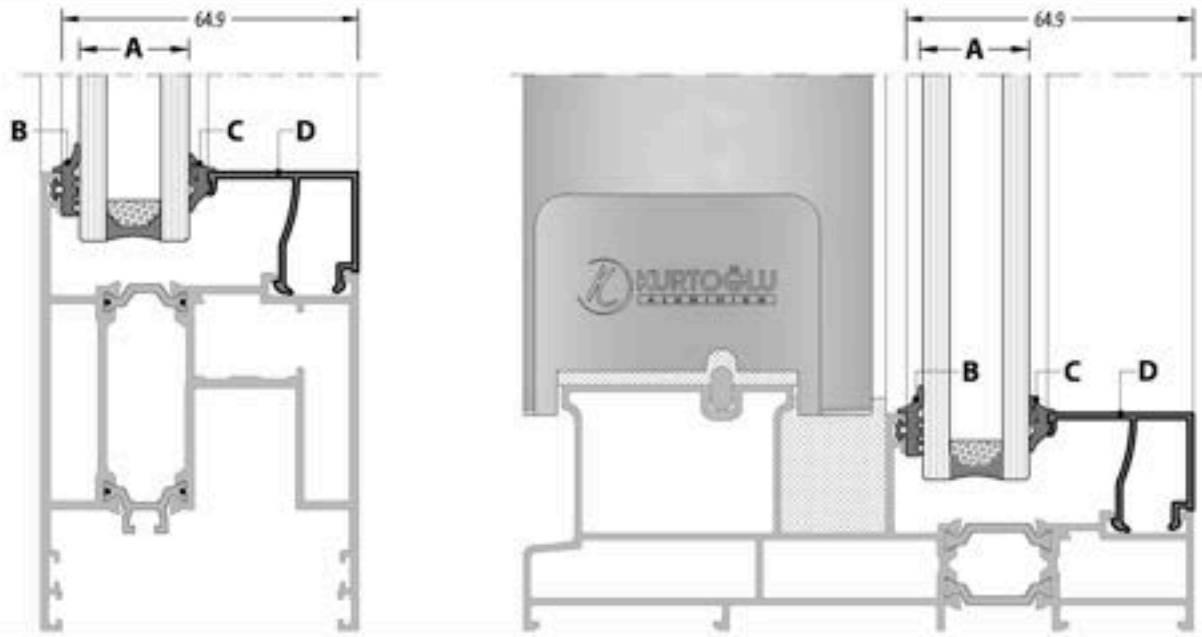

A	B	C	D	A	B	C	D
GLAZING THICKNESS CAM KALINLIĞI	OUTSIDE GLASS GASKET DIŞ CAM FİTİLİ	INSIDE GLASS GASKET İÇ CAM FİTİLİ	GLAZING BEAD CAM ÇİTASI	GLAZING THICKNESS CAM KALINLIĞI	OUTSIDE GLASS GASKET DIŞ CAM FİTİLİ	INSIDE GLASS GASKET İÇ CAM FİTİLİ	GLAZING BEAD CAM ÇİTASI
18 mm	EM2-03	EM1-05	08-116-00	27 mm	EM2-03	EM1-05	08-113-00
19 mm	EM2-03	EM1-04		28 mm	EM2-03	EM1-04	
20 mm	EM2-03	EM1-03		29 mm	EM2-03	EM1-03	
21 mm	EM2-03	EM1-02		30 mm	EM2-03	EM1-02	
22 mm	EM2-03	EM1-05	08-115-00	30 mm	EM2-03	EM1-05	08-112-00
23 mm	EM2-03	EM1-04		31 mm	EM2-03	EM1-04	
24 mm	EM2-03	EM1-03		32 mm	EM2-03	EM1-03	
25 mm	EM2-03	EM1-02		33 mm	EM2-03	EM1-02	
25 mm	EM2-03	EM1-05	08-117-00	33 mm	EM2-03	EM1-05	08-109-00
26 mm	EM2-03	EM1-04		34 mm	EM2-03	EM1-04	
27 mm	EM2-03	EM1-03		35 mm	EM2-03	EM1-03	
28 mm	EM2-03	EM1-02		36 mm	EM2-03	EM1-02	
26 mm	EM2-03	EM1-05	08-114-00	36 mm	EM2-03	EM1-05	08-108-00
27 mm	EM2-03	EM1-04		37 mm	EM2-03	EM1-04	
28 mm	EM2-03	EM1-03		38 mm	EM2-03	EM1-03	
29 mm	EM2-03	EM1-02		39 mm	EM2-03	EM1-02	

GLAZING TABLE / CAM TABLOSU

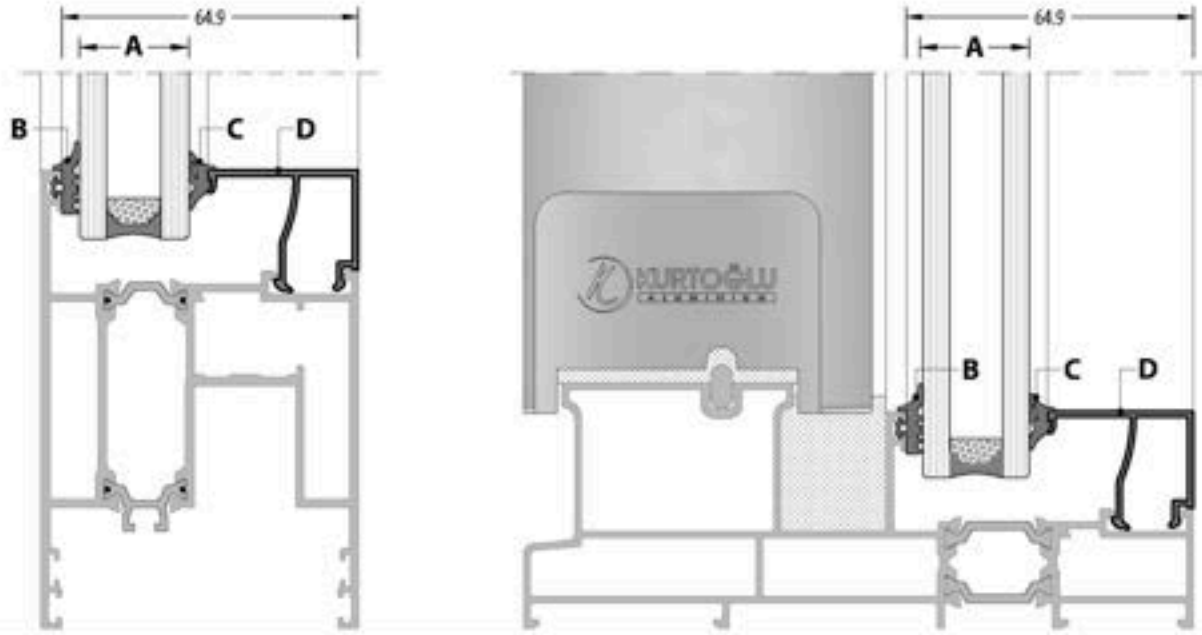













A	B	C	D
GLAZING THICKNESS CAM KALINLIĞI	OUTSIDE GLASS GASKET DIŞ CAM FİTİLİ	INSIDE GLASS GASKET İÇ CAM FİTİLİ	GLAZING BEAD CAM ÇİTASI
38 mm	EM2-03	EM1-05	08-107-00
39 mm	EM2-03	EM1-04	
40 mm	EM2-03	EM1-03	
41 mm	EM2-03	EM1-02	
41 mm	EM2-03	EM1-05	08-105-00
42 mm	EM2-03	EM1-04	
43 mm	EM2-03	EM1-03	
44 mm	EM2-03	EM1-02	
42 mm	EM2-03	EM1-05	08-104-00
43 mm	EM2-03	EM1-04	
44 mm	EM2-03	EM1-03	
45 mm	EM2-03	EM1-02	
45 mm	EM2-03	EM1-05	08-103-00
46 mm	EM2-03	EM1-04	
47 mm	EM2-03	EM1-03	
48 mm	EM2-03	EM1-02	

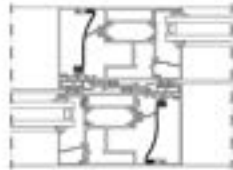

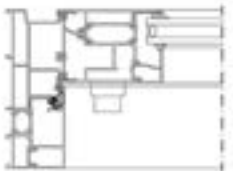



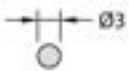
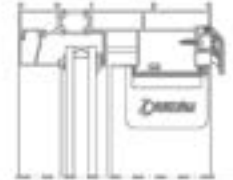









A	B	C	D
GLAZING THICKNESS CAM KALINLIĞI	OUTSIDE GLASS GASKET DIŞ CAM FİTİLİ	INSIDE GLASS GASKET İÇ CAM FİTİLİ	GLAZING BEAD CAM ÇİTASI
48 mm	EM2-03	EM1-05	08-102-00
49 mm	EM2-03	EM1-04	
50 mm	EM2-03	EM1-03	
51 mm	EM2-03	EM1-02	
51 mm	EM2-03	EM1-05	08-101-00
52 mm	EM2-03	EM1-04	
53 mm	EM2-03	EM1-03	
54 mm	EM2-03	EM1-02	

ACCESSORIES
AKSESUARLAR

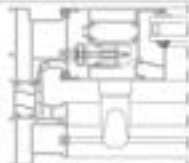
GASKETS / FİTİLLER

CODE / KOD	DRAWING / ÇİZİM	APPLICATION / UYGULAMA	DESCRIPTION AÇIKLAMA	MATERIAL MALZEME	IN ONE PACKAGE PAKET MİKTARI
EM70LS-01			ISOLATION GASKET İZOLASYON FİTİLİ	EPDM	263 m
EM70LS-02			CLAMPING GASKET KENET FİTİLİ	EPDM	405 m
EM70LS-03			SASH GASKET KANAT FİTİLİ	EPDM	366 m
EM70LS-04			CLAMPING GASKET KENET FİTİLİ	EPDM	118 m
EM70LS-05			CAPEG GASKET KAPAK FİTİLİ	EPDM	117 m
EM45-05			FRAME GASKET KASA FİTİLİ	EPDM	550 m
EM51LS-11			CLAMPING GASKET KENET FİTİLİ	Co Extruded	250 m
O.RING-3 mm			O-RING 3 mm	EPDM FOAMGASKET EPDM SÜNGER-FİTİL	500 m



GASKETS / FITİLLER

CODE / KOD	DRAWING / ÇİZİM	APPLICATION / UYGULAMA	DESCRIPTION AÇIKLAMA	MATERIAL MALZEME	IN ONE PACKAGE PAKET MİKTARI
PB-67-600			BRUSH / FIRÇA (7 mm)	-	275 m
PB-67-800			BRUSH / FIRÇA (8 mm)	-	225 m
PB-67-1000			BRUSH / FIRÇA (10 mm)	-	200 m
PB-67-1800			BRUSH / FIRÇA (18 mm)	-	150 m
EM1-02			INSIDE GLASS GASKET İÇ CAM FITİLİ	EPDM	300 m
EM1-03			INSIDE GLASS GASKET İÇ CAM FITİLİ	EPDM	250 m
EM1-04			INSIDE GLASS GASKET İÇ CAM FITİLİ	EPDM	215 m
EM1-05			INSIDE GLASS GASKET İÇ CAM FITİLİ	EPDM	210 m
EM2-03			OUTSIDE GLASS GASKET DIŞ CAM FITİLİ	EPDM	230 m





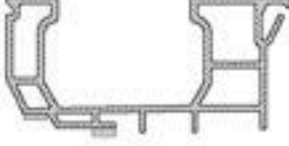

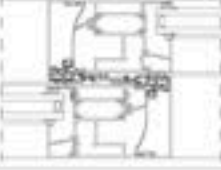



INJECTION / KÖŞE FİTİL

CODE / KOD	DRAWING / ÇİZİM	APPLICATION / UYGULAMA	DESCRIPTION AÇIKLAMA	MATERIAL MALZEME	IN ONE PACKAGE PAKET MİKTARI
EM51LS-C03			INJECTION GASKET ENJEKSİYON FİTİL	EPDM	Set / Takım

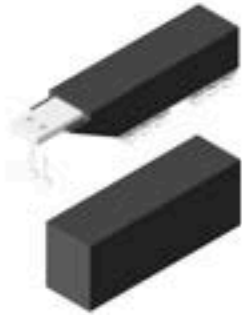











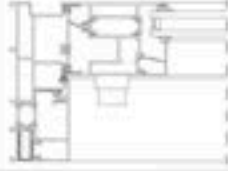

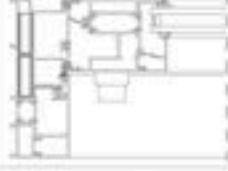

PVC ADAPTER / PVC ADAPTÖR

CODE / KOD	DRAWING / ÇİZİM	APPLICATION UYGULAMA	DESCRIPTION AÇIKLAMA	MATERIAL MALZEME	IN ONE PACKAGE PAKET MİKTARI
EM70LS-11			U PLASTIK U PLASTIC	PVC	6000 mm
EM70LS-12			CLAMP PLASTIC KENET PLASTIĞI	PVC	6000 mm





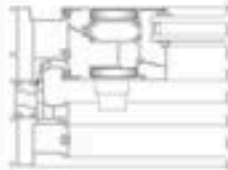

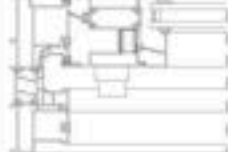



ACCESSORIES / AKSESUARLAR

PACKAGE CODE PAKET KOD	VIEW RESİM	DESCRIPTION AÇIKLAMA	PACKAGE CODE PAKET KOD	VIEW RESİM	DESCRIPTION AÇIKLAMA
EM70LS-21		CLAMPING ACCESSORIES SET KENET AKSESUAR TAKIMI	EM70LS-10		DRAINAGE CAP TAIRIYE KAPAGI
EM70LS-23		FOUR SASH ACCESSORIES SET DORT KANAT AKSESUAR TAKIMI	EM70LS-15		PIPETTE PIPET
EM70LS-31		FIXED WEATHER STRIP SET SABITLI HAVA KESICI TAKIMI	EM70LS-51		DROPPER CAP DAMLALIK KAPAGI
EM70LS-32		WEATHER STRIP SET 2'LI KASA HAVA KESICI TAKIMI	EM70LS-07		SASH STABILITY PLASTIC KANAT DENGE PLASTIG
			EM70LS-29		SASH FIXING WEDGE KANAT SABITLEME TAKOZU
			EM70LS-190		FRAME MONTAGE WEDGE KASA MONTAJ TAKOZU





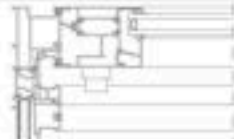

CUTTED CORNER JOINTS / KESİLMİŞ KÖŞE TAKOZLAR

PACKAGE CODE PAKET KODU	DRAWING / ÇİZİM	APPLICATION UYGULAMA	PROFILE CODE PROFİL KODU	CUTTING SIZE KESİM ÖLÇÜSÜ	APPLICATION PROFILES ÇALIŞTIĞI PROFİLLER
CC-101-19.5			09-101-00	19.5 mm	70LS-191-00
CC-102-28.3			09-102-00	28.3 mm	70LS-101-00
CC-102-38.9			09-102-00	38.9 mm	70LS-101-00
CC-102-42.8			09-102-00	42.8 mm	70LS-102-00 70LS-103-00
CC-102-43.7			09-102-00	43.7 mm	70LS-103-00
CC-102-51.7			09-102-00	51.7 mm	70LS-112-00 70LS-113-00
CC-102-55.4			09-102-00	55.4 mm	70LS-102-00 70LS-103-00
CC-105-09.6			09-105-00	9.6 mm	70LS-201-00
CC-110-22.0			09-110-00	22.0 mm	70LS-201-00







MECHANICAL CORNER JOINTS / MEKANİK KÖŞE BAĞLANTILAR

PACKAGE CODE PAKET KODU	DRAWING ÇİZİM	APPLICATION UYGULAMA	PROFILE CODE PROFİL KOD	CUTTING SIZE KESİM ÖLÇÜSÜ	APPLICATION PROFILES ÇALIŞTIĞI PROFİLLER
KC-802-28.1			09-802-00	28.1 mm	70LS-101-00
KC-802-38.7			09-802-00	38.7 mm	70LS-101-00
KC-802-42.6			09-802-00	42.6 mm	70LS-102-00 70LS-103-00
KC-802-43.5			09-802-00	43.5 mm	70LS-103-00
KC-802-51.5			09-802-00	51.5 mm	70LS-112-00 70LS-113-00
KC-802-55.2			09-802-00	55.2 mm	70LS-102-00 70LS-103-00





DIE-CAST CORNER JOINTS / PİMLİ BAĞLANTILAR

PACKAGE CODE PAKET KODU	DRAWING ÇİZİM	APPLICATION UYGULAMA	PROFILE CODE PROFİL KOD	CUTTING SIZE KESİM ÖLÇÜSÜ	APPLICATION PROFILES ÇALIŞTIĞI PROFİLLER
LC-1120			-	-	70LS-191-00
LC-1127			-	-	45T-251-00
LC-122			-	-	07-105-00



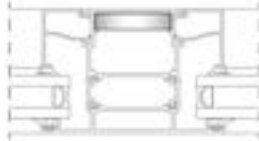

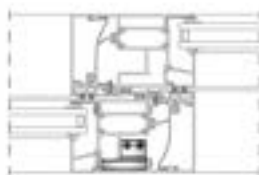
CORNER ACCESSORIES / KÖŞE BAĞLANTILAR

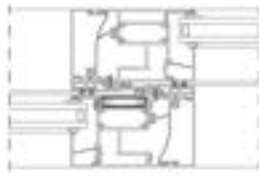
PACKAGE CODE PAKET KODU	DRAWING / ÇİZİM	APPLICATION UYGULAMA	APPLICATION PROFILES ÇALIŞTIĞI PROFİLLER	DESCRIPTION AÇIKLAMA	MATERIAL MALZEME
EM58-21			70LS-101-00 70LS-201-00	CORNER JOINT KÖŞE BAĞLANTI	PVC
MK-20.1			70LS-112-00 70LS-113-00 70LS-191-00 07-102-00 07-103-00	CORNER JOINT KÖŞE BAĞLANTI	METAL
LC-107			70LS-201-00 45T-251-00	CORNER JOINT KÖŞE BAĞLANTI	METAL

T JUNCTIONS / ÇEKTİRME BAĞLANTILAR

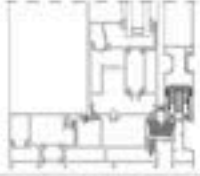
PACKAGE CODE PAKET KODU	DRAWING / ÇİZİM	APPLICATION UYGULAMA	PROFILE CODE PROFİL KODU	CUTTING SIZE KESİM ÖLÇÜSÜ	APPLICATION PROFILES ÇALIŞTIĞI PROFİLLER
CA70-901-42.7			70LS-901-00	42.8 mm	70LS-302-00
CA70-901-42.8 (Left & Right Set) (Sol & Sağ Takım)			70LS-901-00	42.8 mm	70LS-201-00
CA70-902-42.8			70LS-902-00	42.8 mm	70LS-201-00 70LS-302-00

FLY SCREEN ACCESSORIES / SİNEKLİK AKSESUARLARI

PACKAGE CODE PAKET KOD	DRAWING ÇİZİM	APPLICATION UYGULAMA	APPLICATION PROFILES ÇALIŞTIĞI PROFİLLER	DESCRIPTION AÇIKLAMA	MATERIAL MALZEME
EM38-32			45T-251-00	PULLEY WITH 2 WHEELS SİRME İKİLİ RULMAN	.
ZM-07			70LS-191-00	CENTRAL SEAL HAVA KESİCİ	.
ZM-0330			45T-251-00	SASH STOPPER KANAT STOPER	.

CUTTING SIZE
KESİM ÖLÇÜLERİ

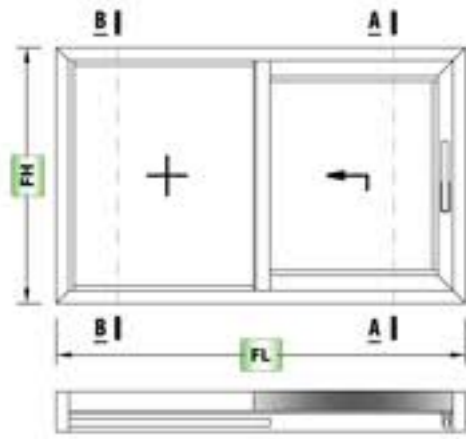

Please look at the assembly drawings for mechanical treatment.
Mekanik işlemler için kesim çizimlerine detaylı bakılmasına bakınız.

FIXED SIDE GLASS / SABİT KISIM CAMI

Code Kod	Drawing Çizim	Quantity Miktar	Dimensions (mm) Boyutlar
Glass Cam		1 Pcs / Adet	GL2 = $\frac{FL}{2}$ - 78.1 GH2 = FH - 68

SASH GLASS / KANAT CAMI

Code Kod	Drawing Çizim	Quantity Miktar	Dimensions (mm) Boyutlar
Glass Cam		1 Pcs / Adet	GL1 = SL - 170.4 GH1 = SH - 170.4

PROFILES / PROFİLLER

Code Kod	Drawing Çizim	Cut Kesim	Quantity Miktar	Dimensions (mm) Boyutlar	Mechanical Treatment Mekanik İşlem
70LS-101-00			2 Pcs / Adet	FL	-
70LS-201-00			2 Pcs / Adet	FH	-
08-115-00			2 Pcs / Adet	SL = $\frac{FL}{2}$ - 7.4	-
			2 Pcs / Adet	SH = FH - 97	-
			1 Pcs / Adet	MH = FH - 54	✓
			2 Pcs / Adet	BL = SL - 156.4	-
13-134-050R			2 Pcs / Adet	BH = SH - 200.4	-
			2 Pcs / Adet	CL = $\frac{FL}{2}$ - 64.1	-
			2 Pcs / Adet	CH = FH - 98	✓
			1 Pcs / Adet	LR = FL - 100	-
70LS-401-00			1 Pcs / Adet	TL = $\frac{FL}{2}$ - 86.1	✓
			1 Pcs / Adet	TH = FH - 82.7	✓
70LS-402-00			1 Pcs / Adet	OL = $\frac{FL}{2}$ - 114.9	-
70LS-501-00			1 Pcs / Adet	AH = SH - 3	✓
			1 Pcs / Adet	KH = FH - 54	✓
70LS-502-00			1 Pcs / Adet	ZH = SH - 3	✓
			1 Pcs / Adet	EH = FH - 98	✓
EM70LS-12			1 Pcs / Adet	PH = SH - 3	✓
			1 Pcs / Adet	NH = FH - 98	✓
70LS-511-00			1 Pcs / Adet	LN = FL - 44	-
70LS-512-00			FL / 400 Pcs / Adet	SS mm	✓

GASKETS / FİTİLLER

Code Kod	Quantity Miktar	Picture Resim
EM1-XX	2SL+2SH+FL+2FH-100	
EM2-03	2SL+2SH+FL+2FH-100	
EM70LS-01	2SH	
EM70LS-02	2SH	
EM70LS-03	2SL+2SH	
EM51LS-03	2SL	
EM70LS-04	2SH	
EM70LS-05	2SL+SH-170	
EM45-05	FL+2FH-300	
O-RING-3 mm	LN = FL - 44	
EM51LS-11	4SH	
PB-7-600	2SL+3SH-170	

CORNER JOINTS / KÖŞE BAĞLANTILAR

Code Kod	Quantity Miktar	Picture Resim
CC-102-38.9 Or / Yada KC-802-38.7 CC-102-28.3 Or / Yada KC-802-28.1	8 Pcs / Adet	
CC-105-09.6	8 Pcs / Adet	
CC-110-22.0	4 Pcs / Adet	
EM58-21	8 Pcs / Adet	
LC-107	8 Pcs / Adet	
CA70-901-42.8	1 Set / Takım	
CA70-902-42.7	2 Pcs / Adet	

ACCESSORIES / AKSESUARLAR

Code Kod	Description Açıklama	Quantity (pcs-m) Miktar (Paket)	Picture Resim
EM70LS-31	WEATHER STRIP SET HAVA KESİCİ TAKIMI (70LS-101-00)	1 Set / Takım	
EM70LS-21	CLAMPING ACCESSORIES SET KİNET AKSESUAR TAKIMI	1 Set / Takım	
EM70LS-51	DROPPER CAP SARILIK KAFAGI	1 Set / Takım	
EM70LS-07	STABILITY ACCESSORY DENGE AKSESUAR	Set / Paket Set / Paket Set / Paket Set / Paket Set / Paket	
EM70LS-10	DRAINAGE CAP SARILIK KAFAGI	Set / Paket Set / Paket Set / Paket Set / Paket Set / Paket	
EM70LS-15	PIPETTE FİPET	(EM70LS-10) / 2 Pcs / Adet	
EM51LS-C03	INJECTION GASKET ENJEKSİYON FİTİL	1 Set / Takım	

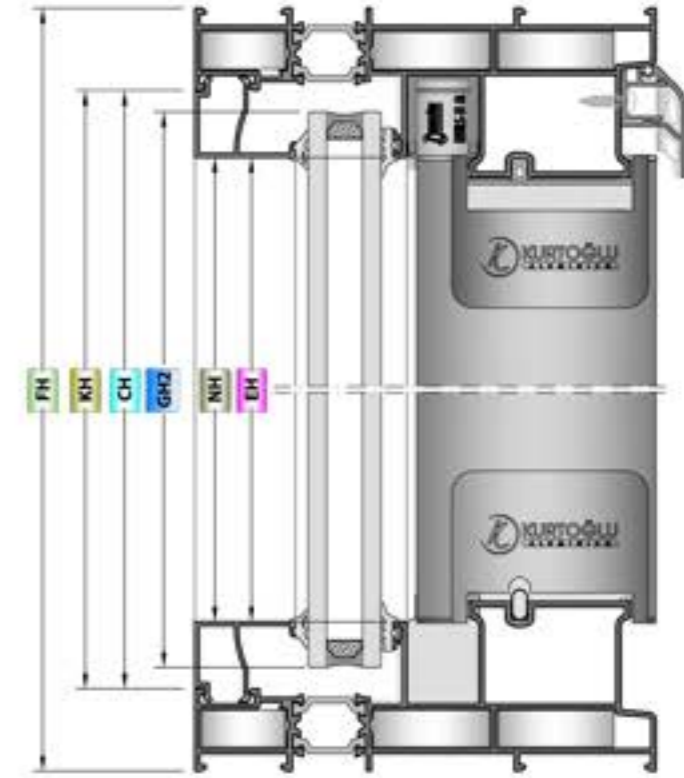

A-A SECTION / A-A KESİTİ

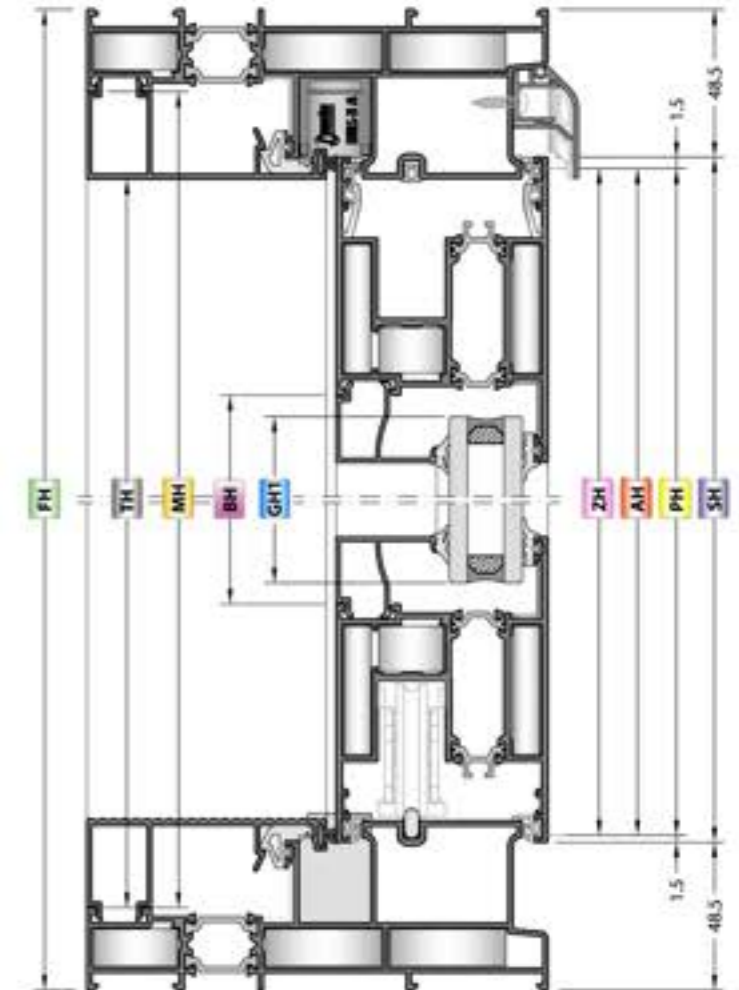

B-B SECTION / B-B KESİTİ

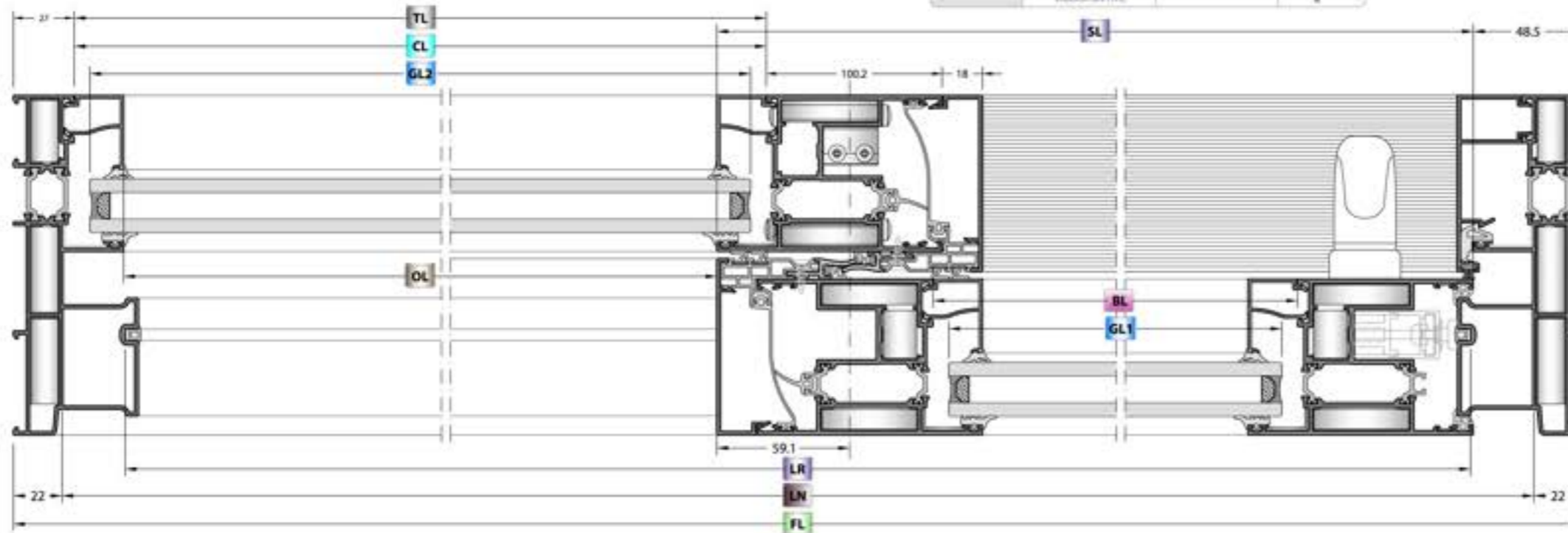

PROFILES / PROFİLLER

Code Kod	Drawing Çizim	Cut Kesim	Quantity Miktar	Dimensions (mm) Boyutlar	Mechanical Treatment Mekanik İşlem
70LS-101-00			2 Pcs / Adet	FL	-
			2 Pcs / Adet	FH	-
70LS-201-00			4 Pcs / Adet	$SL = \frac{FL}{4} + 38.6$	-
			4 Pcs / Adet	SH = FH - 97	-
			2 Pcs / Adet	MH = FH - 54	✓
08-115-00			4 Pcs / Adet	BL = SL - 156.4	-
			4 Pcs / Adet	BH = SH - 200.4	-
			4 Pcs / Adet	CL = SL - 102.7	-
			4 Pcs / Adet	CH = FH - 98	✓
13-134-050R			1 Pcs / Adet	LR = FL - 100	-
70LS-401-00			1 Pcs / Adet	TL = 2SL - 195.4	-
70LS-402-00			1 Pcs / Adet	OL = 2SL - 195.4	-
70LS-501-00			2 Pcs / Adet	AH = SH - 3	✓
			2 Pcs / Adet	KH = FH - 54	✓
70LS-502-00			2 Pcs / Adet	ZH = SH - 3	✓
			2 Pcs / Adet	EH = FH - 98	✓
70LS-503-00			1 Pcs / Adet	KKH = SH - 65.8	✓
EM70LS-12			2 Pcs / Adet	PH = SH - 3	✓
			2 Pcs / Adet	NH = FH - 98	✓
70LS-511-00			1 Pcs / Adet	LN = FL - 44	-
70LS-512-00			FL / 400 Pcs / Adet	55 mm	✓

GASKETS / FİTİLLER

Code Kod	Quantity Miktar	Picture Resim
EM1-XX	4SL + 8SH - 1800	
EM2-03	4SL + 8SH - 1800	
EM70LS-01	5 x SH	
EM70LS-02	4SH	
EM70LS-03	4SL + 4SH	
EM51LS-03	4SL	
EM70LS-04	4SH	
EM70LS-05	4SL - 390	
EM45-05	FL + 2FH - 300	
O-RING-3 mm	LN = FL - 44	
EM51LS-11	8SH	
PB-7-600	4SL	

CORNER JOINTS / KÖŞE BAĞLANTILAR

Code Kod	Quantity Miktar	Picture Resim
CC-102-38.9 Or / Yağı	8 Pcs / Adet	
KC-802-38.7 CC-102-28.3 Or / Yağı	4 Pcs / Adet	
KC-802-28.1	4 Pcs / Adet	
CC-105-09.6	16 Pcs / Adet	
CC-110-22.0	8 Pcs / Adet	
EM58-21	12 Pcs / Adet	
LC-107	16 Pcs / Adet	
CA70-901-42.8	2 Set / Takım	
CA70-902-42.7	4 Pcs / Adet	

ACCESSORIES / AKSESUARLAR

Code Kod	Description Açıklama	Quantity (pcs-m) Miktar (Paket)	Picture Resim
EM70LS-31	WEATHER STRIP SETİ HAVA BİLEK TAYIRI (70LS-101-00)	2 Set / Takım	
EM70LS-21	CLAMPING ACCESSORIES SET KİNET AKSESUAR TAKIMI	2 Set / Takım	
EM70LS-23	FOUR SASH ACCESSORIES SET DÖRT KANAT AKSESUAR TAKIMI	1 Set / Takım	
EM70LS-51	DROPPER CAP SARILAN KAPAK	1 Set / Takım	
EM70LS-07	STABILITY ACCESSORY DENEK AKSESUAR	1 Set / Takım	
EM70LS-10	DRAINAGE CAP TAHİTTE KAPAK	1 Set / Takım	
EM70LS-15	PIPETTE BİPİT	1 (EM70LS-10 / 2 Pcs) / Takım	
EM51LS-C03	INJECTION GASKET ENERJİSİZ FİTİL	2 Set / Takım	

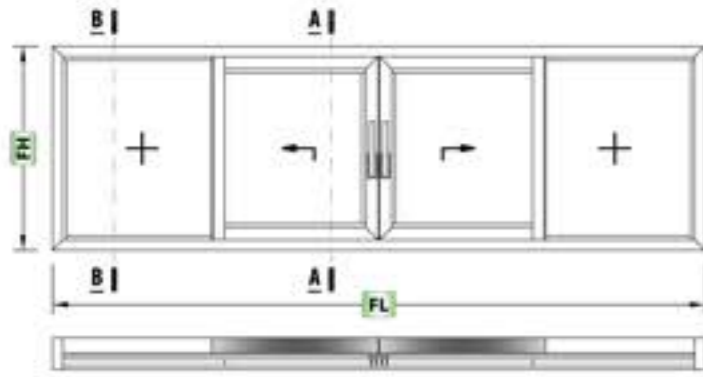

Please look at the assembly drawings for mechanical treatment.
Mekanik işlemler için detaylı aygırlama detayları bilgilendirme bakınız.

FIXED SIDE GLASS / SABİT KISIM CAMI

Code Kod	Drawing Çizim	Quantity Miktar	Dimensions (mm) Boyutlar
Glass Cam		2 Pcs / Adet	$GL2 = \frac{FL}{4} - 78.1$ $GH2 = FH - 68$

SASH GLASS / KANAT CAMI

Code Kod	Drawing Çizim	Quantity Miktar	Dimensions (mm) Boyutlar
Glass Cam		2 Pcs / Adet	$GL1 = SL - 170.4$ $GH1 = SH - 170.4$

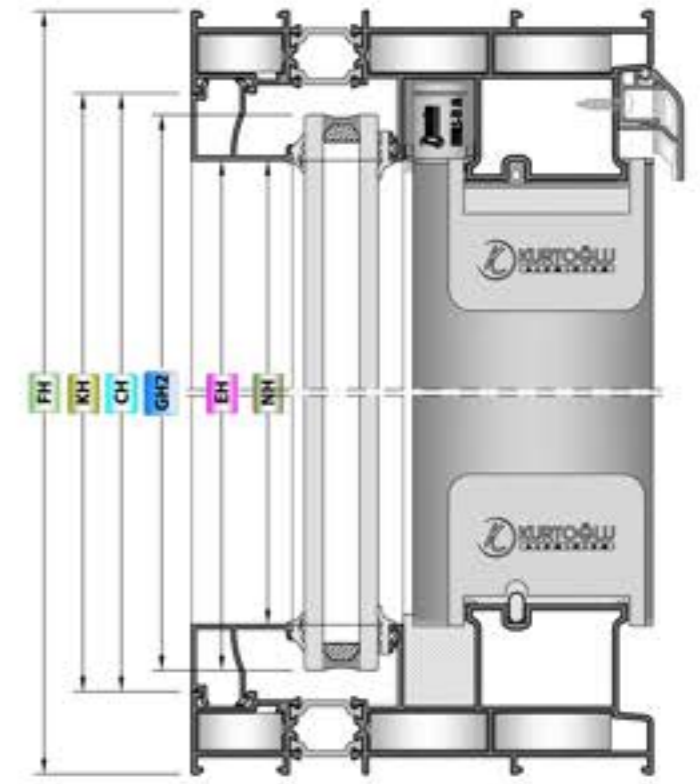

A-A SECTION / A-A KESİTİ

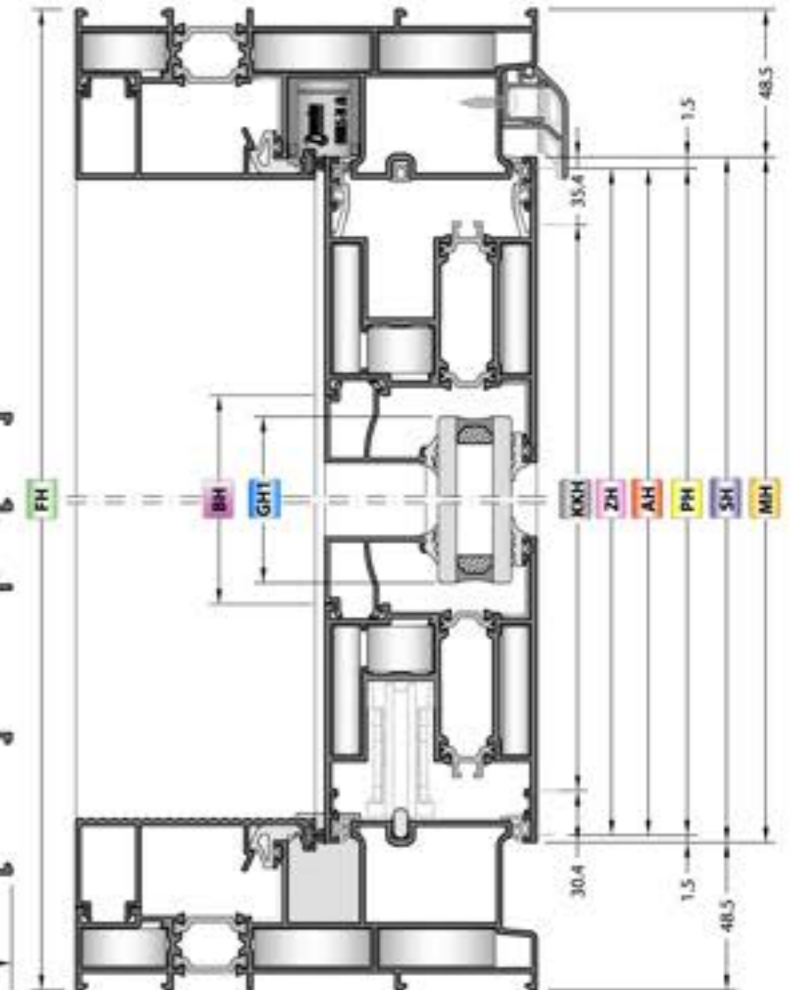
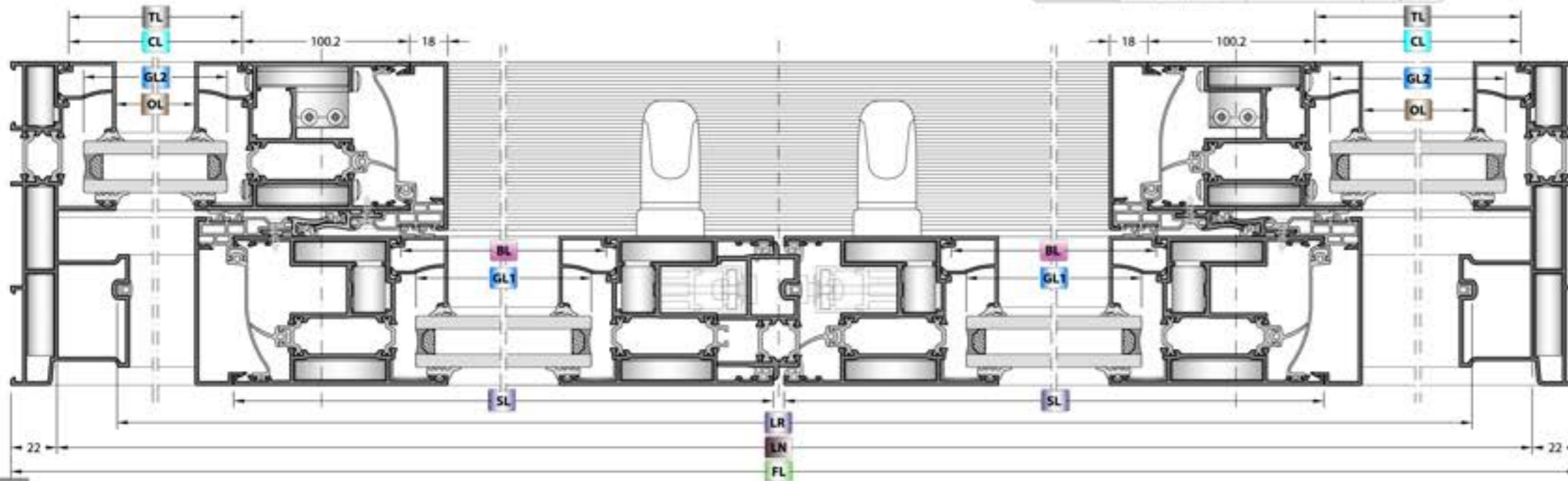

B-B SECTION / B-B KESİTİ

PROFILES / PROFİLLER

Code Kod	Drawing Çizim	Cut Kesim	Quantity Miktar	Dimensions (mm) Boyutlar	Mechanical Treatment Mekanik İşleme
70LS-101-00			2 Pcs / Adet	FL	-
			2 Pcs / Adet	FH	-
70LS-201-00			4 Pcs / Adet	$SL = \frac{FL}{4} + 38.6$	-
			4 Pcs / Adet	$SH = FH - 97$	-
			2 Pcs / Adet	$MH = FH - 54$	✓
			4 Pcs / Adet	$BL = SL - 156.4$	-
08-115-00			4 Pcs / Adet	$BH = SH - 200.4$	-
			4 Pcs / Adet	$CL = SL - 102.7$	-
			4 Pcs / Adet	$CH = FH - 98$	✓
			4 Pcs / Adet	$OH = FH - 98$	✓
13-134-050R			1 Pcs / Adet	LR = FL - 100	-
70LS-401-00			1 Pcs / Adet	TL = 2SL - 195.4	-
70LS-402-00			1 Pcs / Adet	OL = 2SL - 195.4	-
70LS-501-00			2 Pcs / Adet	AH = SH - 3	✓
			2 Pcs / Adet	KH = FH - 54	✓
70LS-502-00			2 Pcs / Adet	ZH = SH - 3	✓
			2 Pcs / Adet	EH = FH - 98	✓
70LS-503-00			1 Pcs / Adet	KKH = SH - 65.8	✓
EM70LS-12			2 Pcs / Adet	PH = SH - 3	✓
			2 Pcs / Adet	NH = FH - 98	✓
70LS-511-00			1 Pcs / Adet	LN = FL - 44	-
70LS-512-00			FL / 400 Pcs / Adet	SS mm	✓

GASKETS / FİTİLLER

Code Kod	Quantity Miktar	Picture Resim
EM1-XX	95L + 95H - 1800	
EM2-03	95L + 95H - 1800	
EM70LS-01	5 x SH	
EM70LS-02	4SH	
EM70LS-03	4SL + 4SH	
EM51LS-03	4SL	
EM70LS-04	4SH	
EM70LS-05	4SL - 390	
EM45-05	FL + 2FH - 300	
O-RING-3 mm	LN = FL - 44	
EM51LS-11	8SH	
PB-7-600	4SL	

CORNER JOINTS / KÖŞE BAĞLANTILARI

Code Kod	Quantity Miktar	Picture Resim
CC-102-38.9 Or / Yağlı	8 Pcs / Adet	
KC-802-38.7	4 Pcs / Adet	
CC-102-28.3 Or / Yağlı	4 Pcs / Adet	
KC-802-28.1	16 Pcs / Adet	
CC-105-09.6	8 Pcs / Adet	
CC-110-22.0	8 Pcs / Adet	
EM58-21	12 Pcs / Adet	
LC-107	16 Pcs / Adet	
CA70-901-42.8	2 Set / Takım	
CC70-902-42.8	4 Pcs / Adet	

ACCESSORIES / AKSESUARLAR

Code Kod	Description Açıklama	Quantity (pcs m) Miktar (Paket)	Picture Resim
EM70LS-31	WEATHER STRIP SETİ HAVA KESİTİ TAKIMI (70LS-101-00)	2 Set / Takım	
EM70LS-21	CLAMPING ACCESSORIES SET KAVIYI AKSESUAR TAKIMI	2 Set / Takım	
EM70LS-23	FOUR SASH ACCESSORIES SET DÖRT KANAT AKSESUAR TAKIMI	1 Set / Takım	
EM70LS-51	DROPPER CAP DAMLALEX KAPAK	1 Set / Takım	
EM70LS-07	STABILITY ACCESSORY DENGE AKSESUAR	Set / Takım <small>Set / Takım (200mm x 80mm x 10mm) / (200mm x 80mm x 10mm) / (200mm x 80mm x 10mm)</small>	
EM70LS-10	DRAINAGE CAP TAVUKLU KAPAK	1 Set / Takım <small>2 - 200 x 200mm, 4 - 200mm x 100mm, 4 - 200mm x 100mm, 4 - 200mm x 100mm</small>	
EM70LS-15	PIPETTE PİPET	(EM70LS 10) / 2 Pcs / Adet	
EM51LS-C03	INJECTION GASKET ENJEKSYON FİTİLİ	2 Set / Takım	

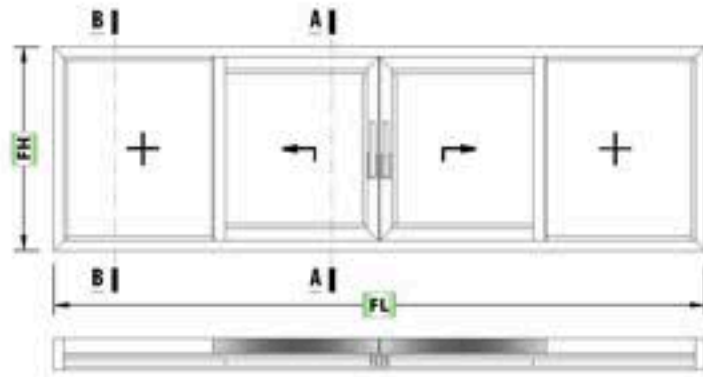

Please look at the assembly drawings for mechanical treatment.
Mekanik işleme için montaj çizimlerine bakılmalıdır.

FIXED SIDE GLASS / SABİT KISIM CAMI

Code Kod	Drawing Çizim	Quantity Miktar	Dimensions (mm) Boyutlar
Glass Cam		2 Pcs / Adet	$GL2 = \frac{FL}{4} - 78.1$ $GH2 = FH - 68$

SASH GLASS / KANAT CAMI

Code Kod	Drawing Çizim	Quantity Miktar	Dimensions (mm) Boyutlar
Glass Cam		2 Pcs / Adet	$GL1 = SL - 170.4$ $GH1 = SH - 170.4$

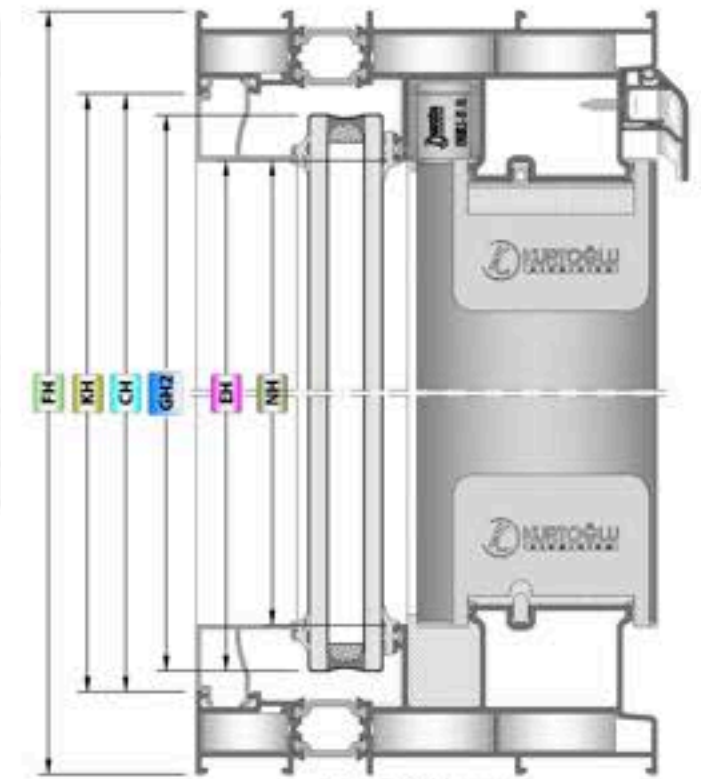

A-A SECTION / A-A KESİTİ

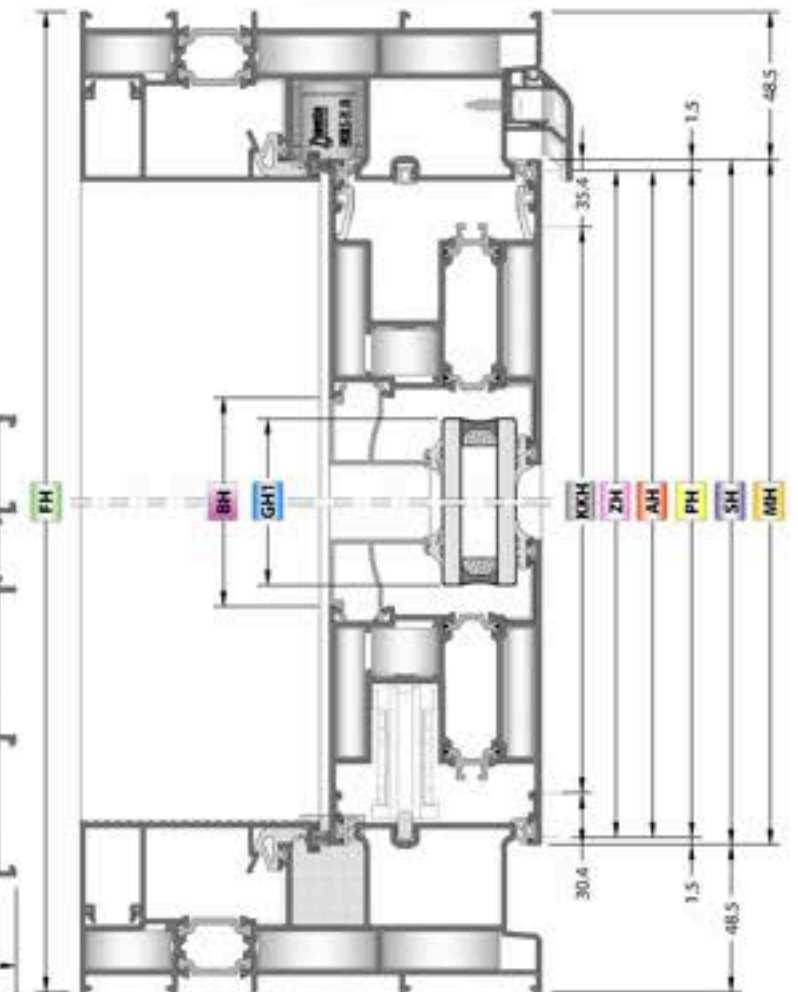
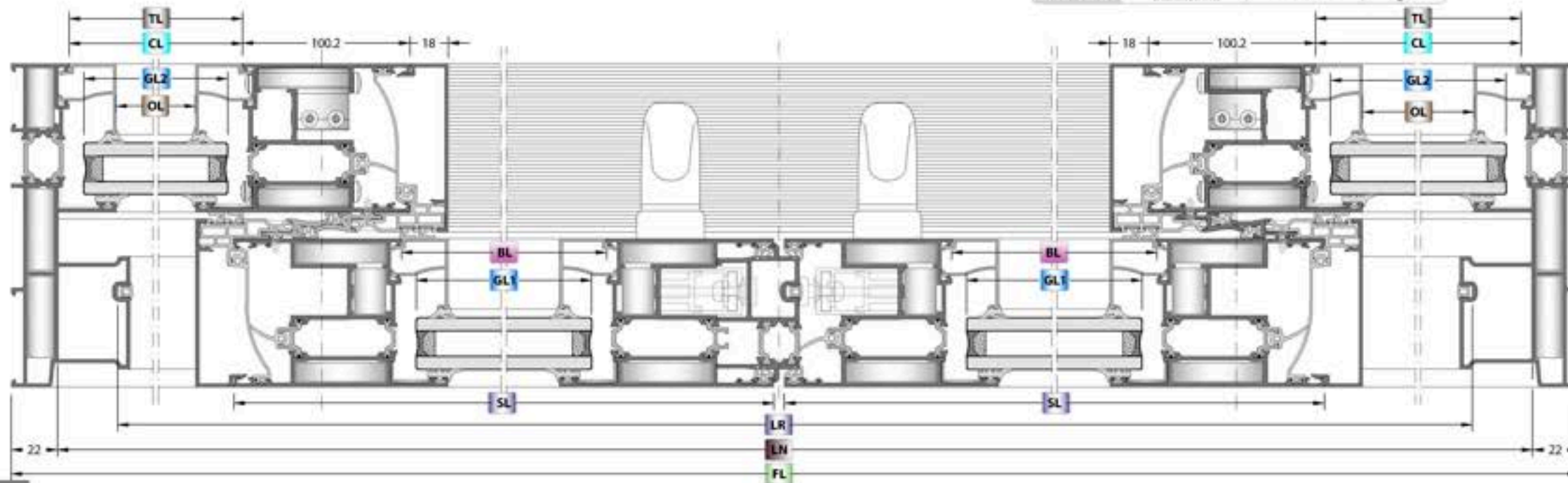

B-B SECTION / B-B KESİTİ

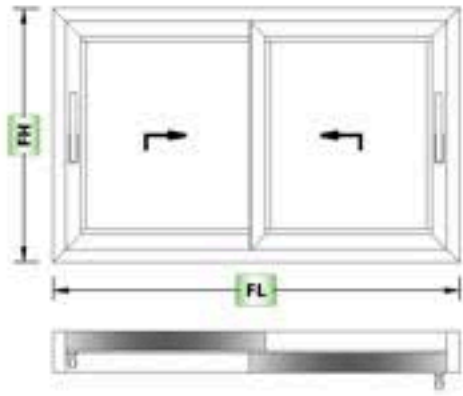

✓ Please look at the assembly drawings for mechanical treatment.
Mekanik işlemler için detaylı uygulamaya detaylı bakılmalıdır.

GLASS / CAM

Code / Kod	Drawing / Çizim	Quantity / Miktar	Dimensions (mm) / Boyutlar
Glass / Cam		2 Pcs / Adet	GL = SL - 170.4 GH = SH - 170.4

PROFILES / PROFİLLER

Code / Kod	Drawing / Çizim	Cut / Kesim	Quantity / Miktar	Dimensions (mm) / Boyutlar	Mechanical Treatment / Mekanik İşleme
70LS-102-00			2 Pcs / Adet	FL	-
			2 Pcs / Adet	FH	-
70LS-201-00			4 Pcs / Adet	SL = $\frac{FL}{2} - 7.4$	-
			4 Pcs / Adet	SH = FH - 97	-
08-115-00			4 Pcs / Adet	BL = SL - 156.4	-
			4 Pcs / Adet	BH = SH - 200.4	-
13-134-050R			2 Pcs / Adet	LR = FL - 100	-
70LS-501-00			2 Pcs / Adet	AH = SH - 3	✓
70LS-502-00			2 Pcs / Adet	ZH = SH - 3	✓
EM70LS-11			2 Pcs / Adet	PUL = FL - 51.4	-
			2 Pcs / Adet	PUH = FL - 51.4	-
EM70LS-12			2 Pcs / Adet	PH = SH - 3	✓
70LS-511-00			1 Pcs / Adet	LN = FL - 44	-
70LS-512-00			FL / 400 Pcs / Adet	55 mm	✓

TWO RAIL FRAME / İKİ RAYLI KASA

GASKETS / FİTİLLER

Code / Kod	Quantity / Miktar	Picture / Resim
EM1-XX	4SL + 4SH	
EM2-03	4SL + 4SH	
EM70LS-01	2SL + 3SH	
EM70LS-02	2SH	
EM70LS-03	4SL + 4SH	
EMS1LS-03	4SL	
EM70LS-04	2SH	
EM4S-05	2FL + 4FH	
O.RING-3 mm	LN = FL	
EMS1LS-11	4SH	

CORNER JOINTS / KÖŞE BAĞLANTILAR

Code / Kod	Quantity / Miktar	Picture / Resim
CC-102-55.4 Or / Yağlı	4 Pcs / Adet	
KC-802-55.2 CC-102-42.8 Or / Yağlı	4 Pcs / Adet	
KC-802-42.6	4 Pcs / Adet	
CC-105-09.6	16 Pcs / Adet	
CC-110-22.0	8 Pcs / Adet	
EMS8-21	8 Pcs / Adet	
LC-107	16 Pcs / Adet	

ACCESSORIES / AKSESUARLAR

Code / Kod	Description / Açıklama	Quantity (pcs-m) / Miktar (Paket)	Picture / Resim
EM70LS-32	WEATHER STRIP SET / HAVA KESİCİ TAKIMI DOLS-102-00	1 Set / Takım	
EM70LS-21	CLAMPING ACCESSORIES SET / KEMET AKSESUAR TAKIMI	2 Set / Takım	
EM70LS-51	DROPPER CAP / DAMLALE KAPAK	1 Set / Takım	
EM70LS-07	STABILITY ACCESSORY / DENGE AKSESUAR	1 Set / Takım 100x100x100 mm / 100x100x100 mm / 100x100x100 mm / 100x100x100 mm	
EM70LS-10	DRAINAGE CAP / TAHLİLE KAPAK	1 Pcs / Adet Ø100 x 15 + 100mm / Ø100 x 15 + 100mm / Ø100 x 15 + 100mm / Ø100 x 15 + 100mm	
EM70LS-15	PIPETTE / PİPET	Ø10x15 10/2 Pcs / Adet	
EMS1LS-C03	INJECTION GASKET / ENJEKSİYON FİTİL	2 Set / Takım	

Two Rail Frame / İki Raylı Kasa

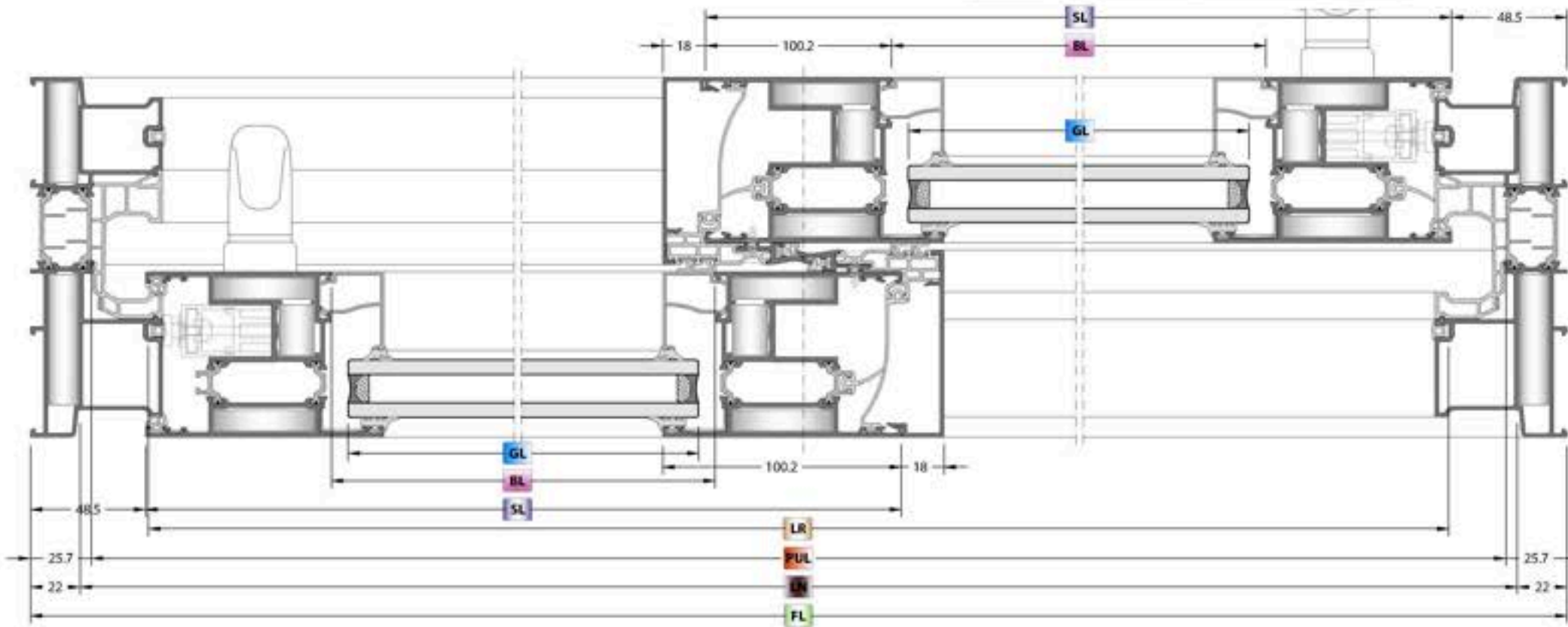
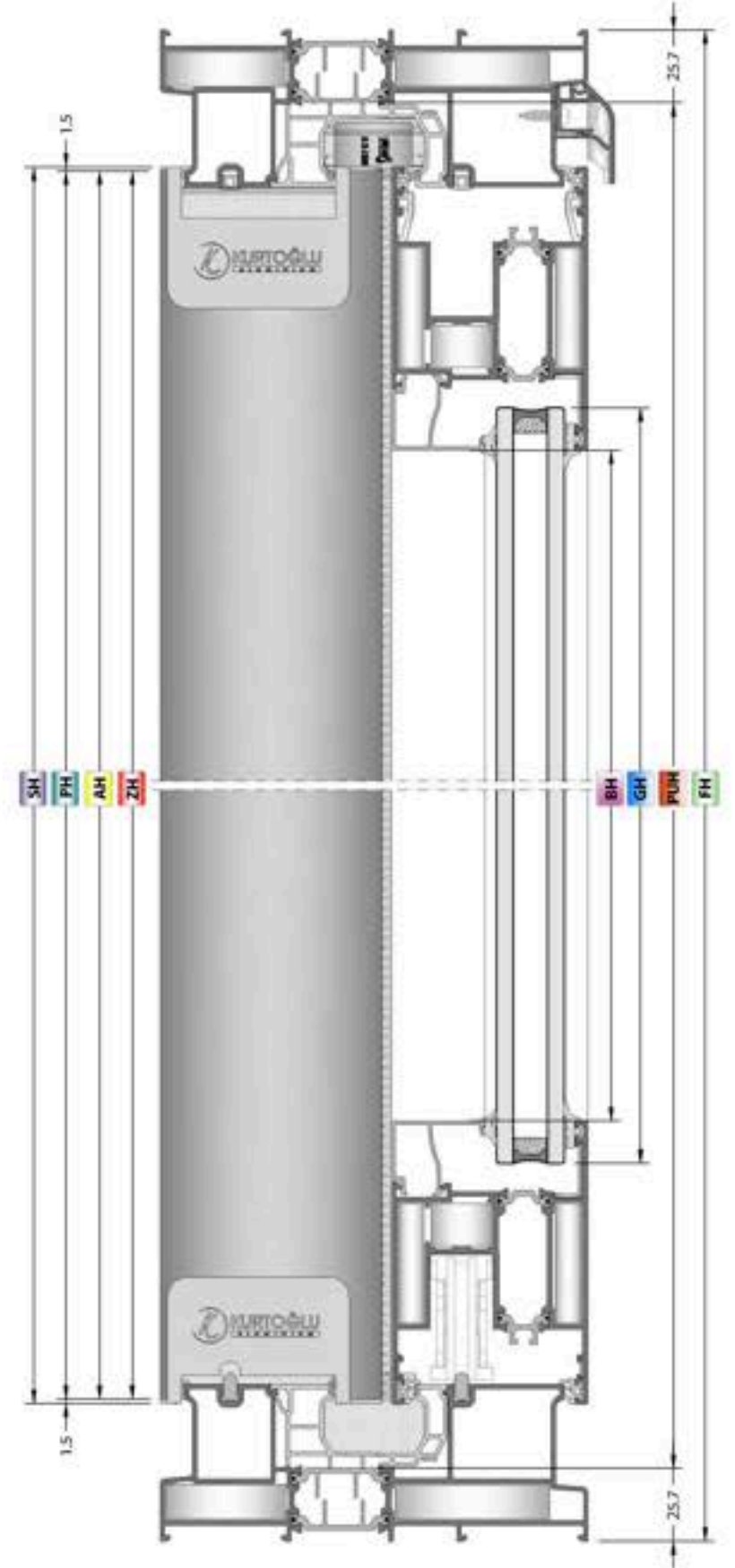

CUTTING SIZE / KESİM ÖLÇÜLERİ

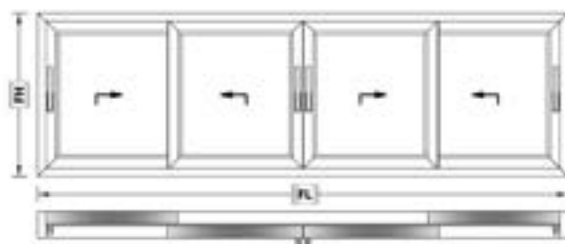

✓ Please look at the assembly drawing for mechanical treatment.
 Mekanik işleme için montaj çizimine bakınız.

ACCESSORIES / EKLEMLER

Code / Kod	Description / Açıklama	Quantity / Qty (Set)	Picture / Resim
EM70LS-32	WEATHER STRIP SET HAVA KIZIL TAPANI (70LS-102-00)	2 Set / Takım	
EM70LS-21	CLAMPING ACCESSORIES SET KIZIL EKLEMLER TAKIMI	4 Set / Takım	
EM70LS-23	FOUR SADE ACCESSORIES SET DÖRT SADE EKLEMLER TAKIMI	1 Set / Takım	
EM70LS-511	DROPPER CAP DAMAÇLIĞI EKLEME	1 Set / Takım	
EM70LS-07	STABILITY ACCESSORY SABİTLİK EKLEMESİ	1 Set / Takım	
EM70LS-10	DRAINAGE CAP SU KIZIL EKLEME	1 Set / Takım	
EM70LS-15	PIPE BORU	(EM70LS-10 / 2) 2 Parça / Parçalar	
EM51LS-C03	INJECTION GASKET SIZDIRMAZICI EKLEME	4 Set / Takım	

PROFILES / PROFİLLER

Code / Kod	Drawing / Çizim	Cut / Kesim	Quantity / Miktar	Dimensions (mm) / Boyutlar	Mechanical Treatment / Mekanik İşleme
70LS-102-00			2 Pcs / Adet	FL	-
70LS-201-00			8 Pcs / Adet	SL = FL-102 + 81,1	-
08-115-00			8 Pcs / Adet	BL = SL - 156,4	-
13-134-050R			2 Pcs / Adet	LR = FL-100	-
70LS-501-00			4 Pcs / Adet	AH = SH - 3	✓
70LS-502-00			4 Pcs / Adet	ZH = SH - 3	✓
70LS-503-00			1 Pcs / Adet	KOH = SH - 70,8	-
EM70LS-11			2 Pcs / Adet	PLS = FL - 51,4	-
EM70LS-12			4 Pcs / Adet	PH = SH - 3	✓
70LS-511-00			1 Pcs / Adet	LN = FL - 44	-
70LS-512-00			1 / 400 Pcs / Adet	SS mm	✓

TWO RAIL FRAME / İKİ RAYLI KASA

GASKETS / TITLİLER

Code / Kod	Quantity / Miktar	Picture / Resim
EM1-XX	85L + 85H	
EM2-03	85L + 85H	
EM70LS-01	45L + 75H	
EM70LS-02	45H	
EM70LS-03	85L + 85H	
EM51LS-03	85L	
EM70LS-04	45H	
EM45-05	2FL + 3FH	
O-RING-3 mm	LN = FL	
EM51LS-11	85H	

CORNER JOINTS / KÖŞE BAĞLANTILAR

Code / Kod	Quantity / Miktar	Picture / Resim
CC-102-55.4 Or Profile	4 Pcs / Adet	
RC-802-55.2	4 Pcs / Adet	
CC-102-42.8 Or Profile	4 Pcs / Adet	
RC-802-42.6	4 Pcs / Adet	
CC-105-09.6	32 Pcs / Adet	
CC-110-22.0	16 Pcs / Adet	
EM58-21	16 Pcs / Adet	
LC-187	32 Pcs / Adet	

GLASS / CAM

Code / Kod	Drawing / Çizim	Quantity / Miktar	Dimensions (mm) / Boyutlar
Glass / Cam		4 Pcs / Adet	GL = SL - 170,4 GH = SH - 170,4

Two Rail Frame / İki Raylı Kasa

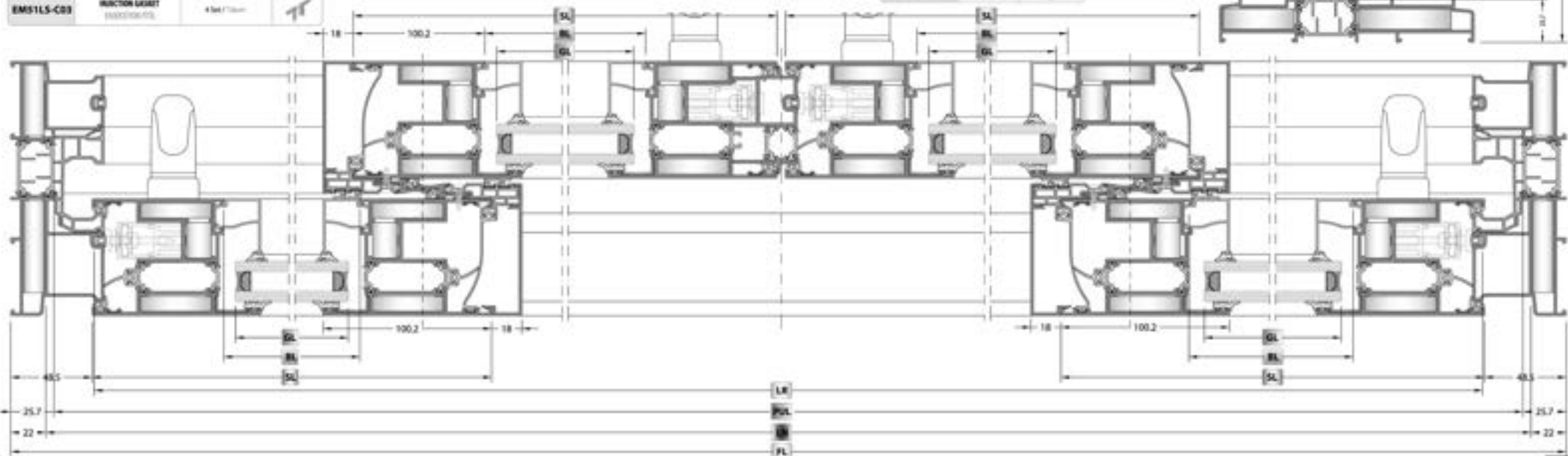
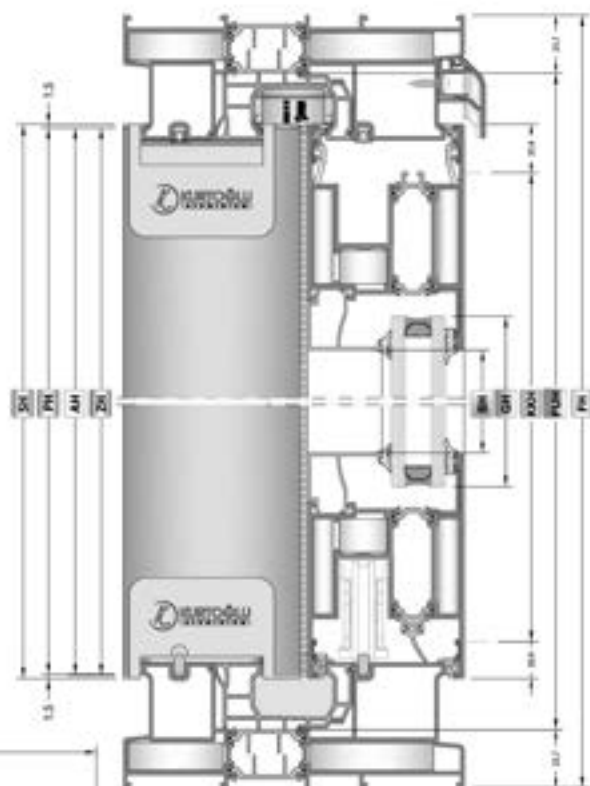

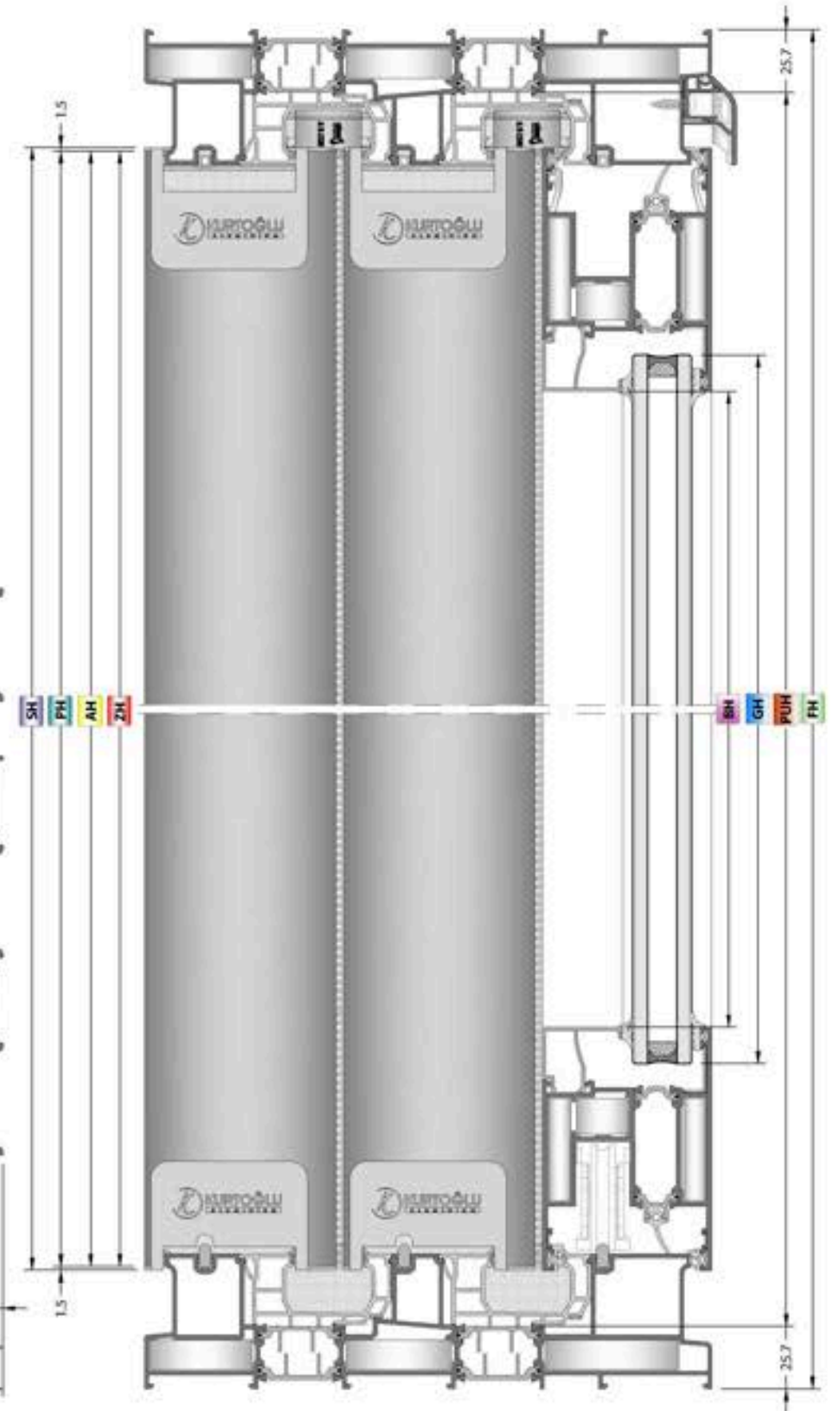
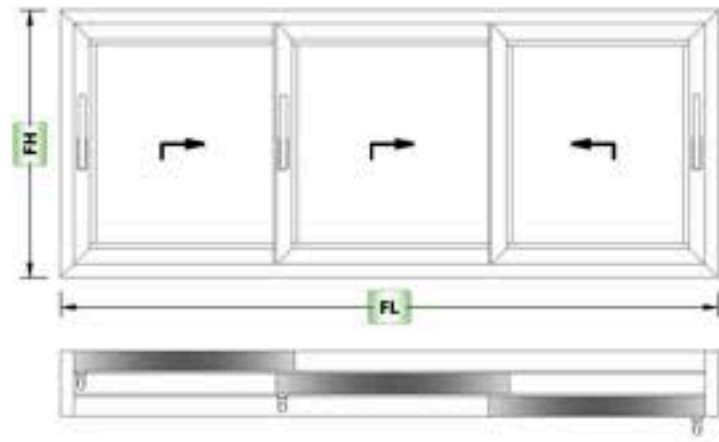

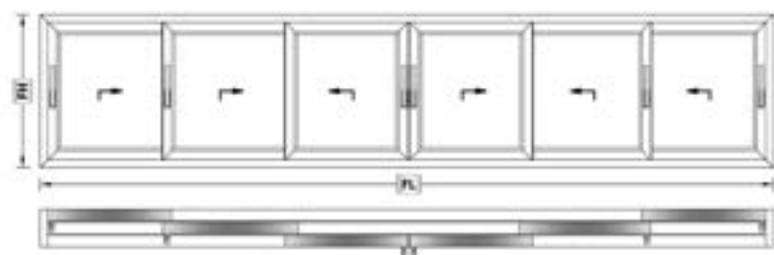

GLASS / CAM			
Code / Kod	Drawing / Çizim	Quantity / Miktar	Dimensions (mm) / Boyutlar
Glass / Cam		6 Pcs./ Adet	GL = SL - 170,4 GH = SH - 170,4

✓ Please look at the assembly drawing for mechanical treatment.
Mekanik işleme için birleştirme çizimini dikkatlice inceleyiniz.

PROFILES / PROFİLLER

Code / Kod	Drawing / Çizim	Qty / Miktar	Quantity / Miktar	Dimensions (mm) / Boyutlar	Mechanical Treatment / Mekanik İşleme
70LS-103-00		2 Pcs./ Adet	FL		-
70LS-201-00		12 Pcs./ Adet	SL = FL - 102 + 34,8		-
70LS-202-00		12 Pcs./ Adet	SH = PH - 97		-
00-110-00		8 Pcs./ Adet	BL = SL - 150,4		-
13-134-0000		12 Pcs./ Adet	SH = SH - 200,4		-
70LS-301-00		4 Pcs./ Adet	LR = FL - 100		-
70LS-302-00		4 Pcs./ Adet	RR = SH - 3		✓
70LS-303-00		4 Pcs./ Adet	TR = SH - 3		✓
70LS-304-00		4 Pcs./ Adet	QR = SH - 70,8		-
EM70LS-11		4 Pcs./ Adet	PUL = FL - 31,8		-
EM70LS-12		4 Pcs./ Adet	PH = FH - 31,8		-
70LS-011-00		4 Pcs./ Adet	PH = SH - 3		✓
70LS-012-00		1 Pcs./ Adet	LN = FL - 46		-
70LS-013-00		2 Pcs./ Adet	55 mm		✓

ACCESSORIES / EKLEMLER

Code / Kod	Description / Açıklama	Quantity / Miktar	Picture / Resim
EM70LS-02	WATER STOP GIP (100x10x10) (70LS-10-00)	4 Pcs./ Adet	
EM70LS-01	CAPPING ACCESSORY (70LS-10-00)	4 Pcs./ Adet	
EM70LS-03	FOR WIND ACCESSORY (70LS-10-00)	4 Pcs./ Adet	
EM70LS-011	SPRING GIP (100x10x10)	1 Pcs./ Adet	
EM70LS-07	SPRING ACCESSORY (100x10x10)	1 Pcs./ Adet	
EM70LS-10	WIND GIP (100x10x10)	1 Pcs./ Adet	
EM70LS-13	WIND (100x10x10)	1 Pcs./ Adet	
EM70LS-C03	WIND GIP (100x10x10)	4 Pcs./ Adet	

GASKETS / YITELER

Code / Kod	Quantity / Miktar	Picture / Resim
EM1-KX	120L + 120H	
EM2-03	120L + 120H	
EM70LS-01	80L + 170H	
EM70LS-02	80H	
EM70LS-03	120L + 80H	
EM5TLS-03	120L	
EM70LS-04	80H	
EM45-05	3FL + 3FH	
O-RING 3 mm	LN = FL	
EM5TLS-11	100H	

CORNER JOINTS / KÖŞE BAĞLANTILAR

Code / Kod	Quantity / Miktar	Picture / Resim
CC-102-43.8	4 Pcs./ Adet	
KC-802-43.6	4 Pcs./ Adet	
CC-102-43.7	4 Pcs./ Adet	
KC-802-43.5	4 Pcs./ Adet	
CC-102-55.4	4 Pcs./ Adet	
KC-802-55.2	4 Pcs./ Adet	
CC-105-09.6	48 Pcs./ Adet	
CC-110-22.0	24 Pcs./ Adet	
EM50-21	24 Pcs./ Adet	
LC-107	48 Pcs./ Adet	

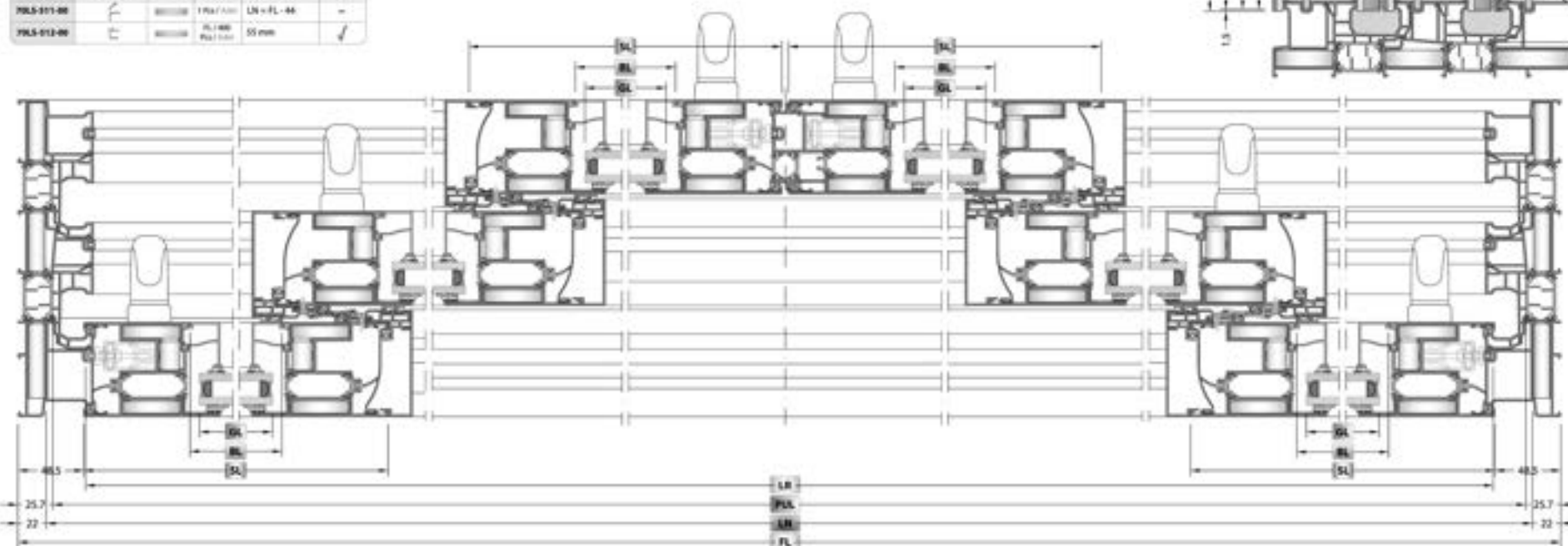
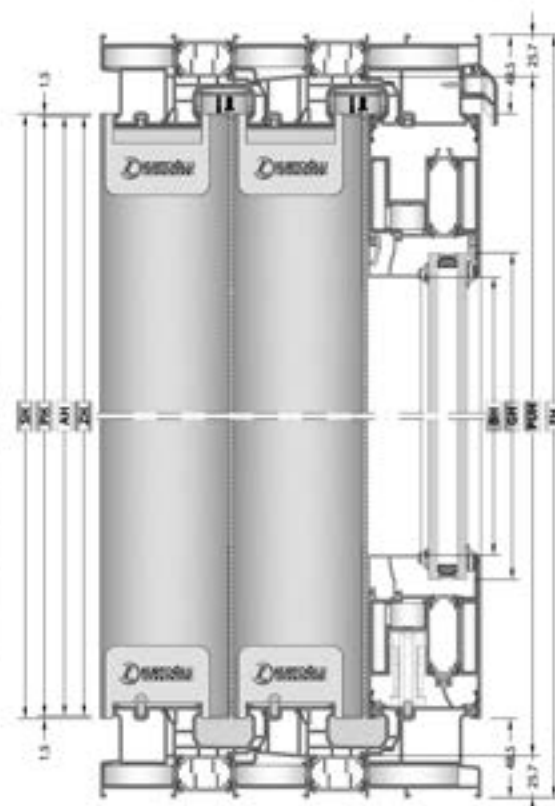

ASSEMBLY DETAILS
MONTAJ DETAYLARI

FRAME ASSEMBLY / KASA UYGULAMA

70LS-101-00

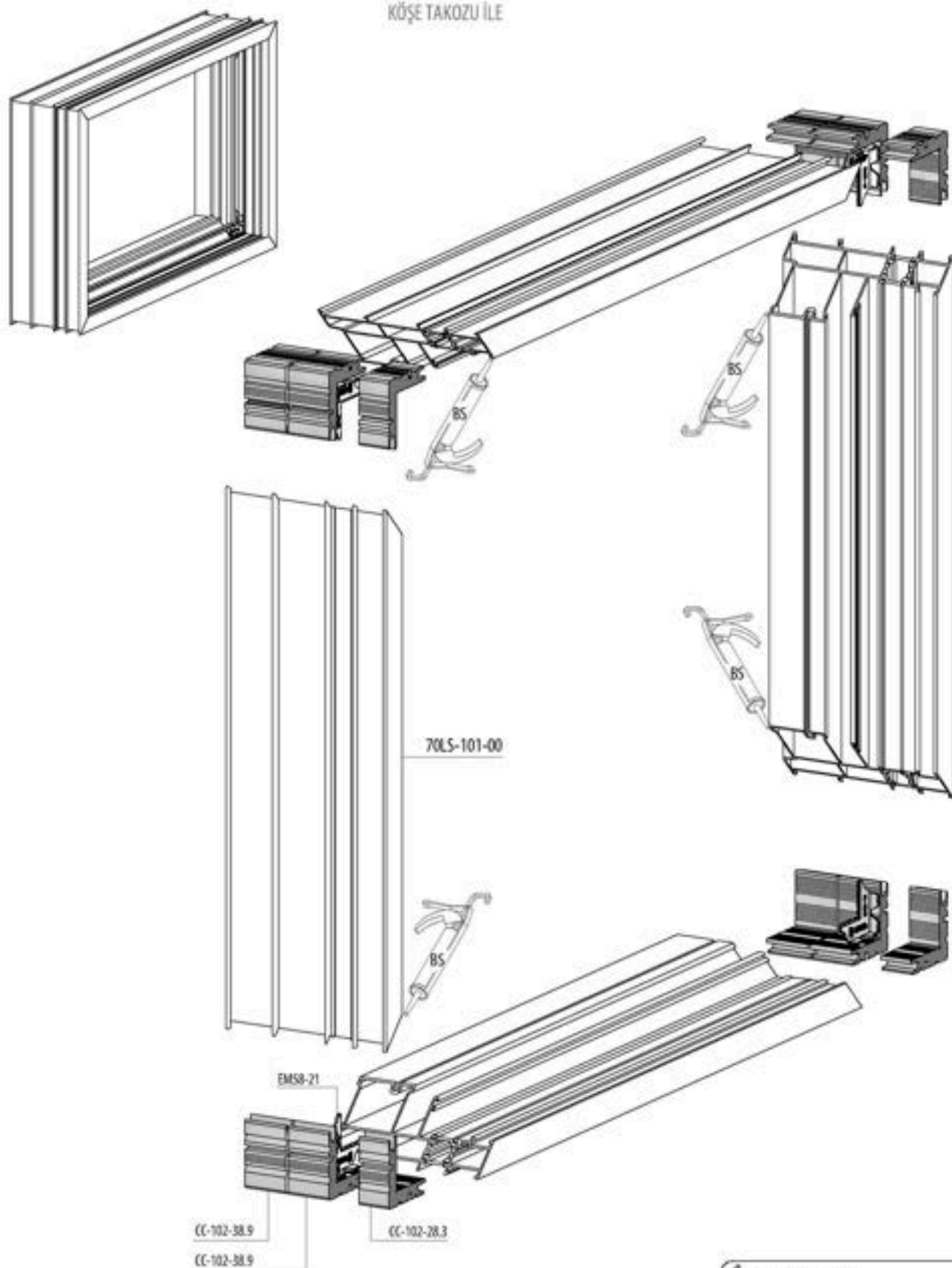
WITH PRES CORNER JOINT
KÖŞE TAKOZU İLE

S = SILICONE / SİLİKON
 ES = EPDM BOND / EPDM YAPISICI
 BS = BOND AND SEAL / KAPISIZLIK VE SIZDIRMAZ

FRAME ASSEMBLY / KASA UYGULAMA

70LS-101-00

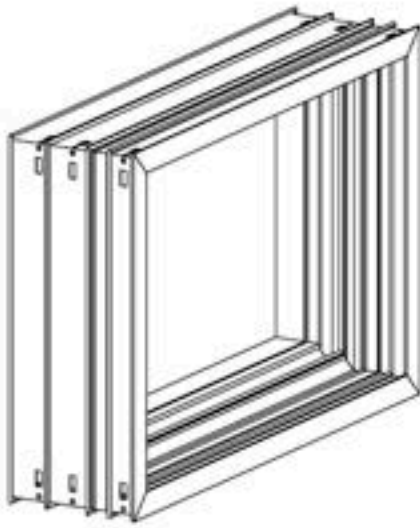

WITH
MECHANICAL
CORNER JOINT
MEKANİK KÖŞE
BAĞLANTI

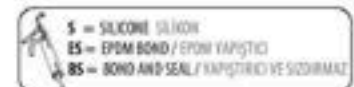
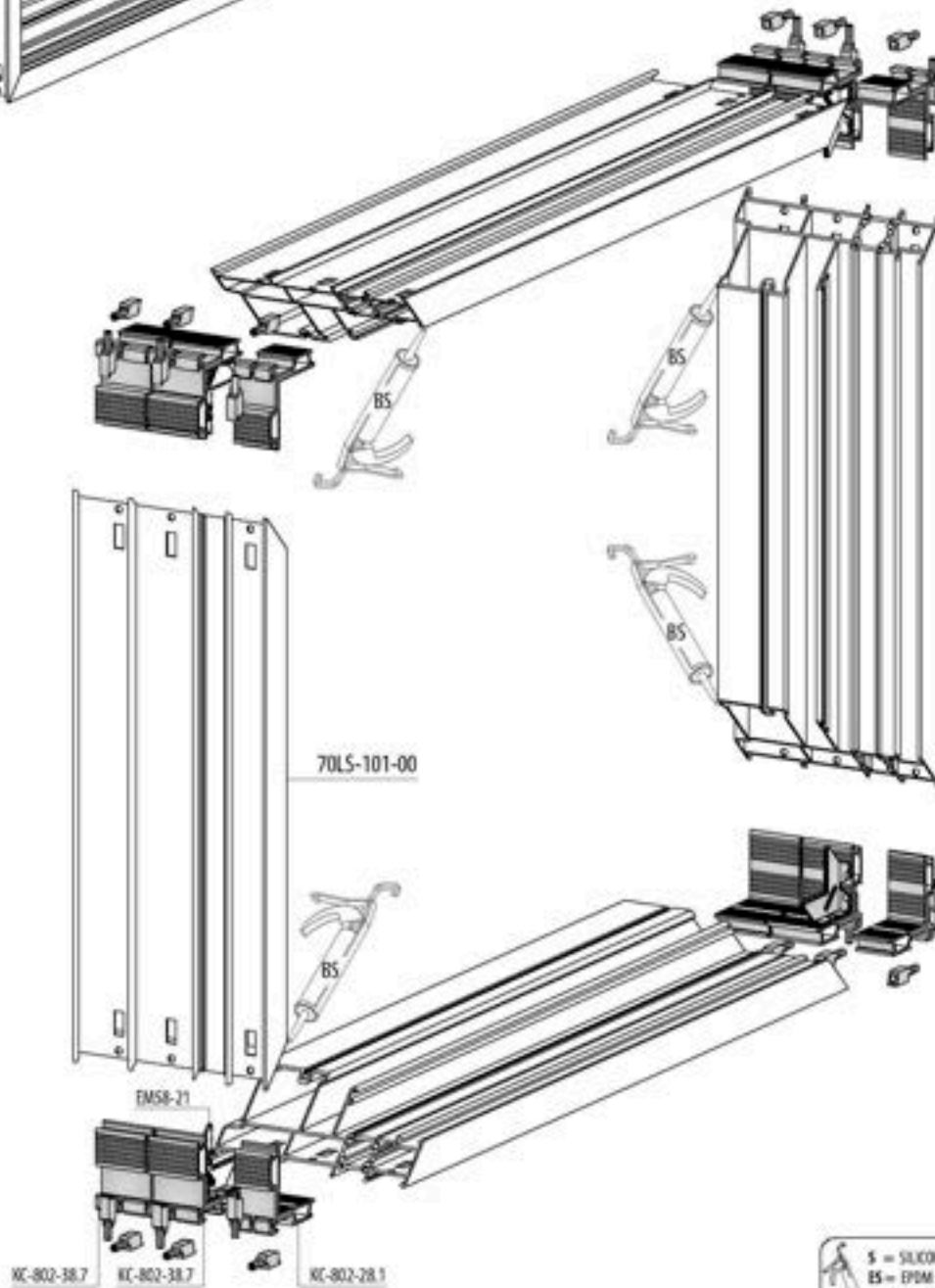
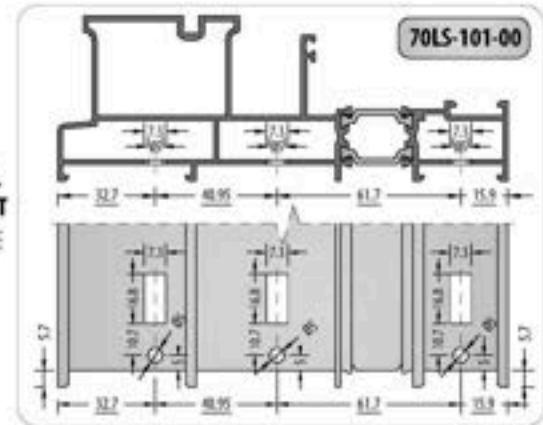

PASSIVE SIDE DRAINAGE / PASİF TARAF TAHLİYE

70LS-101-00

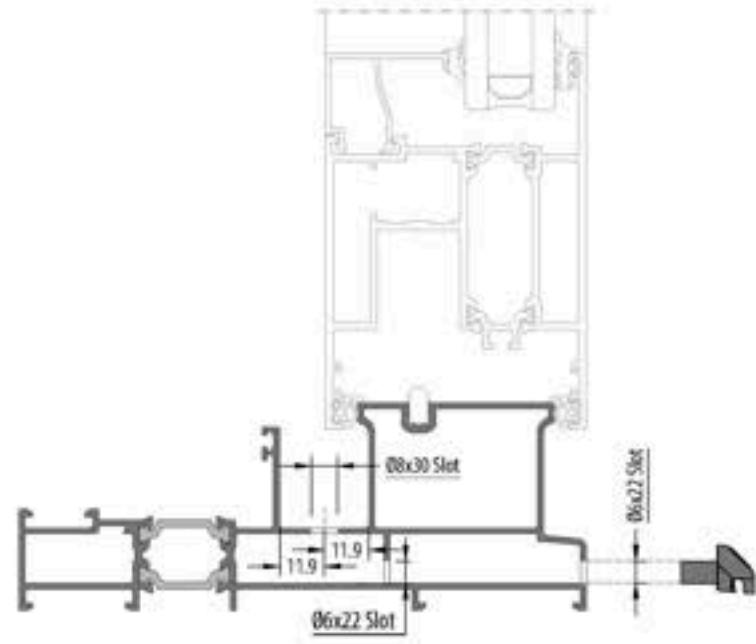
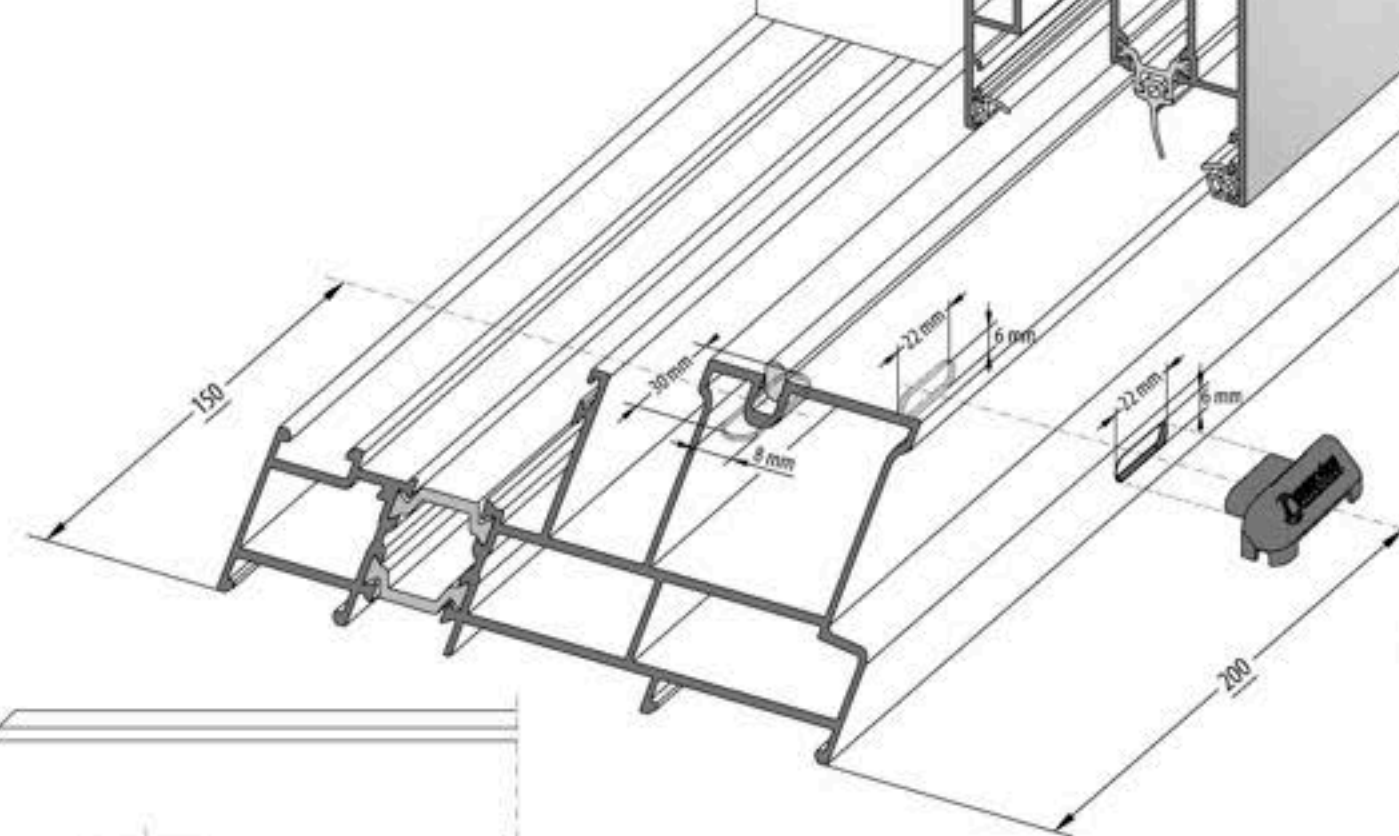
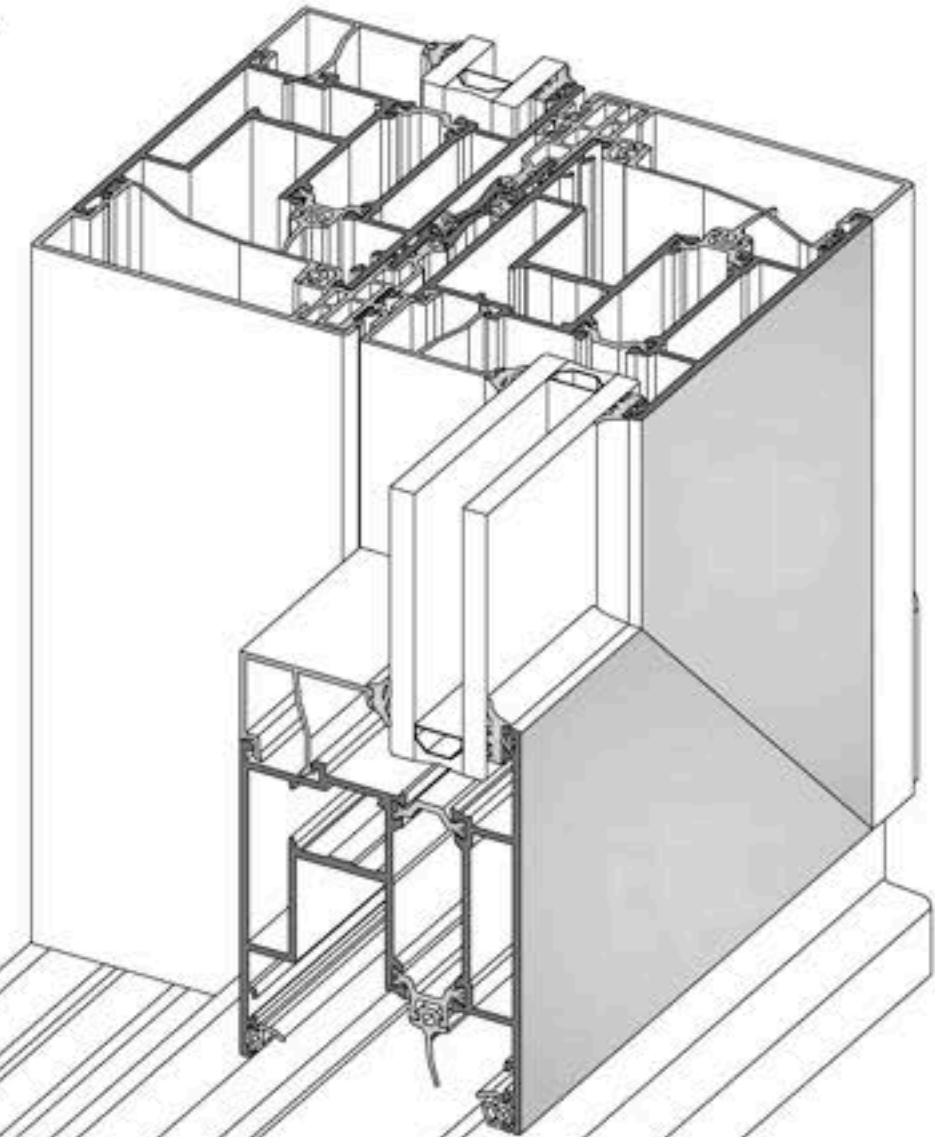
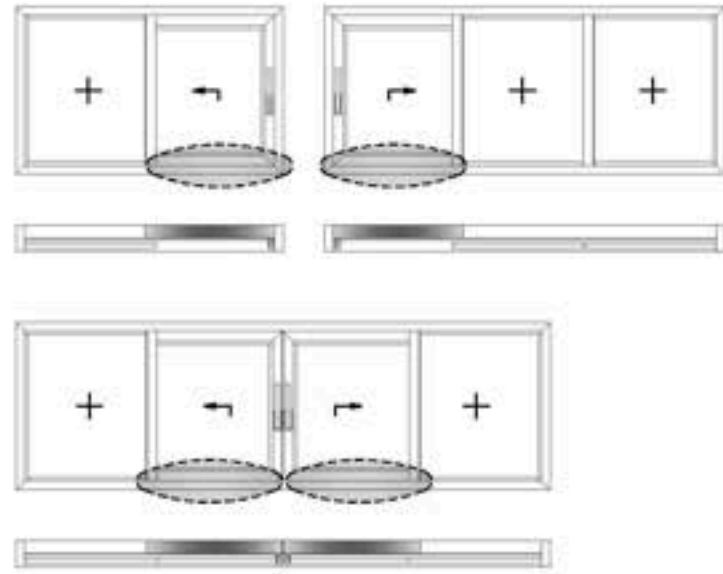
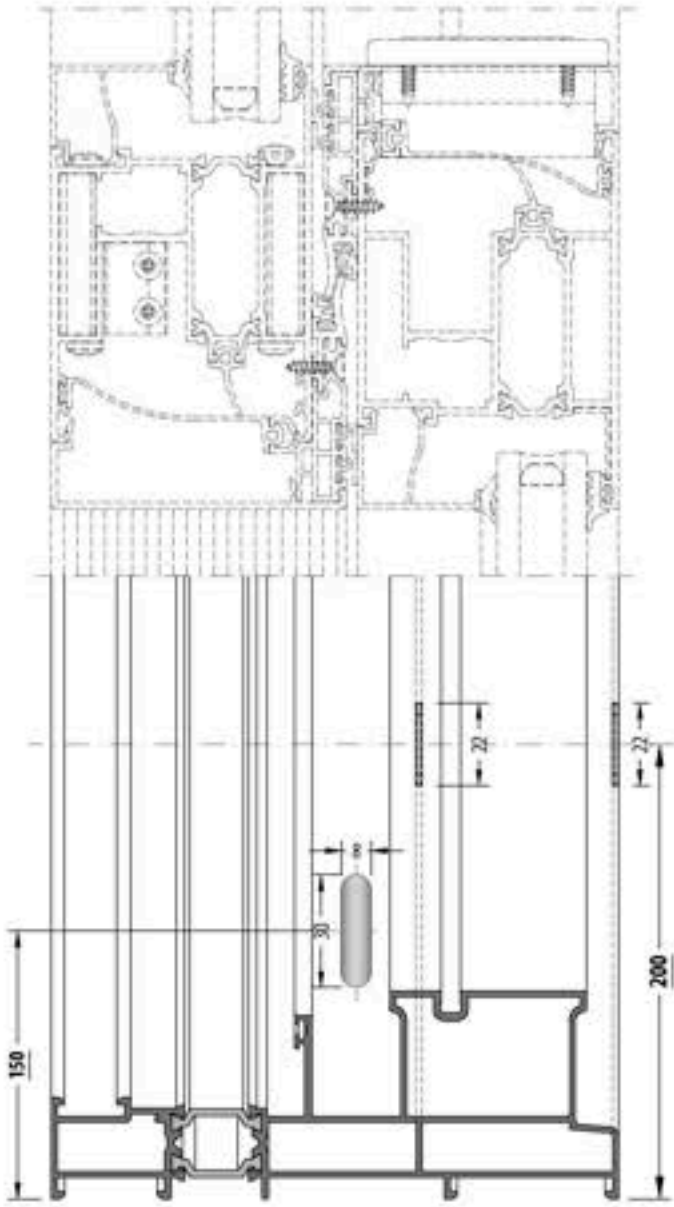

EM70LS-10
Checkvalve must used.
Çekvalf kullanılmalıdır.

ACTIVE SIDE DRAINAGE / AKTIF TARAF TAHLİYE

70LS-101-00

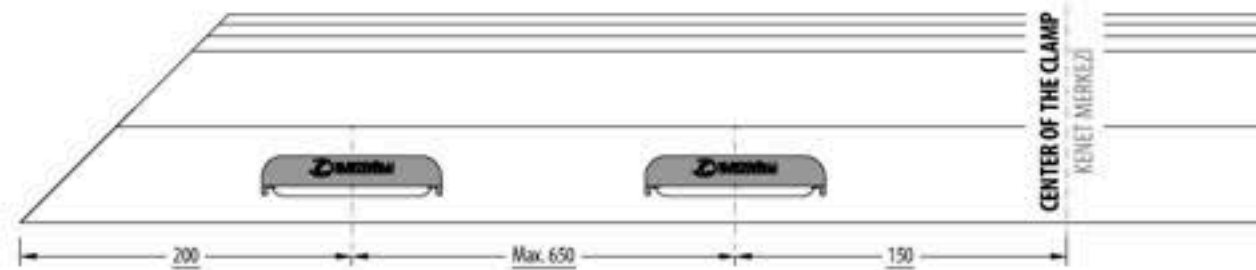
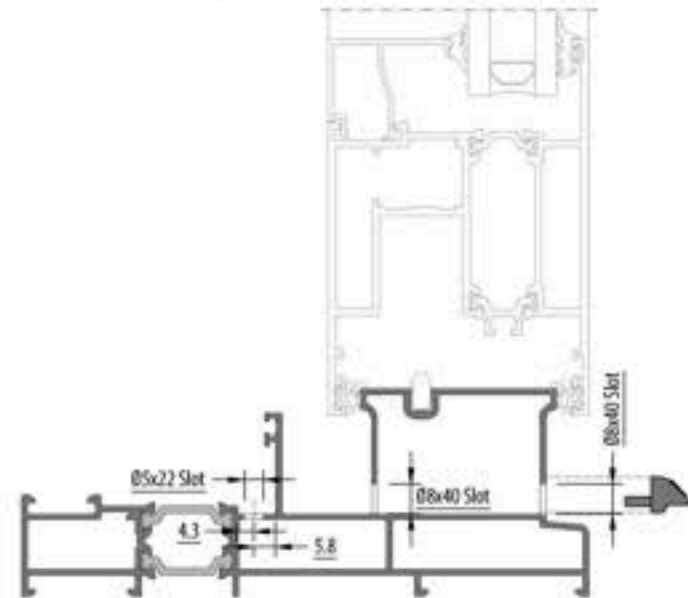
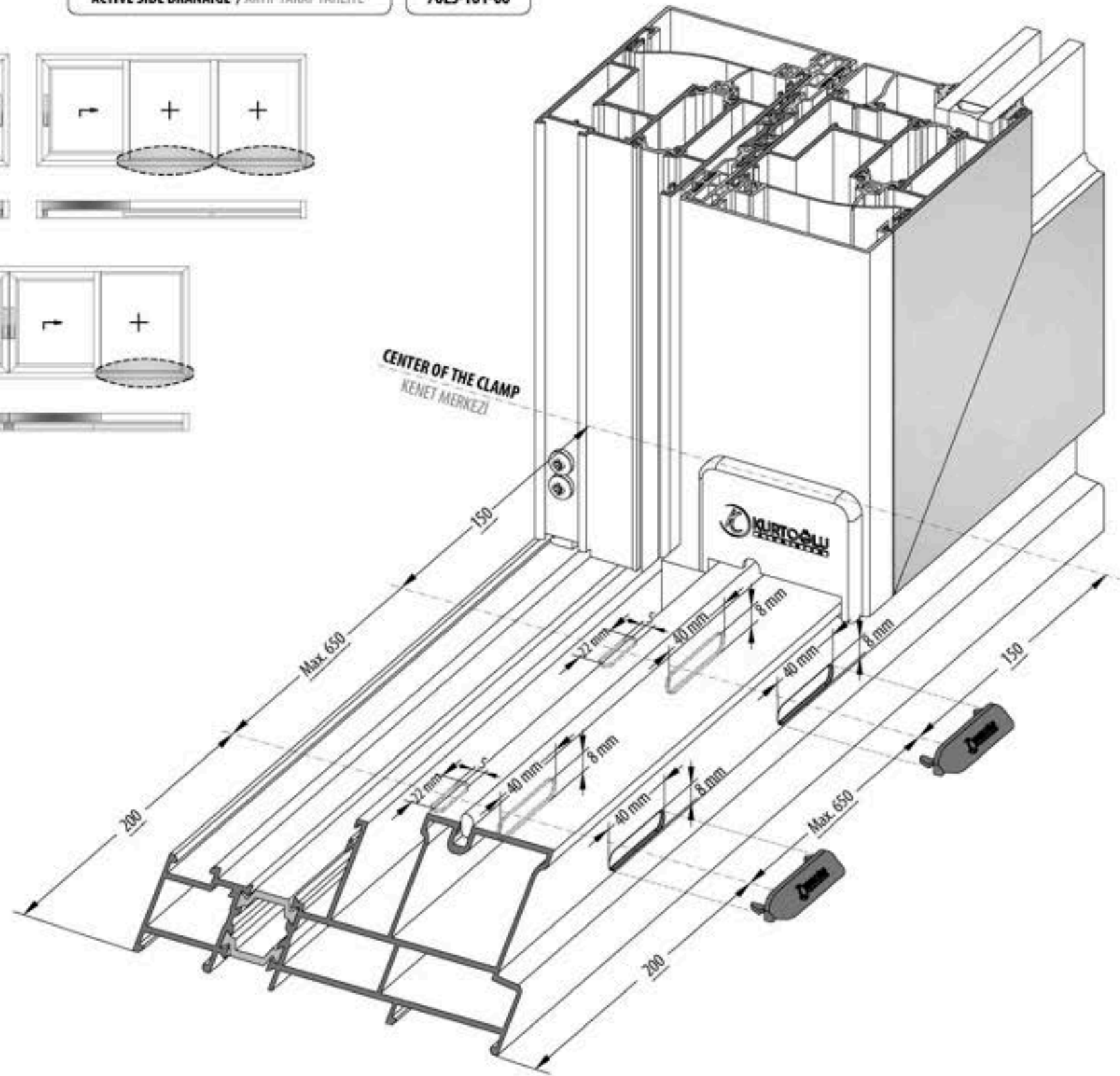
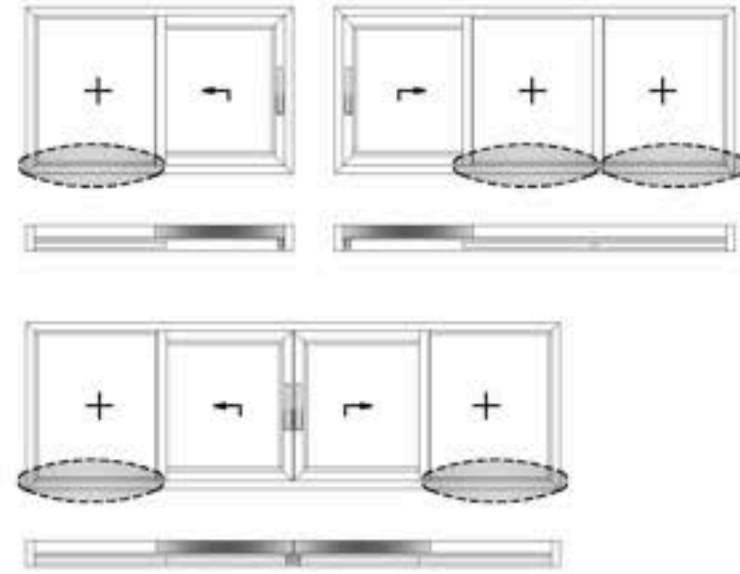
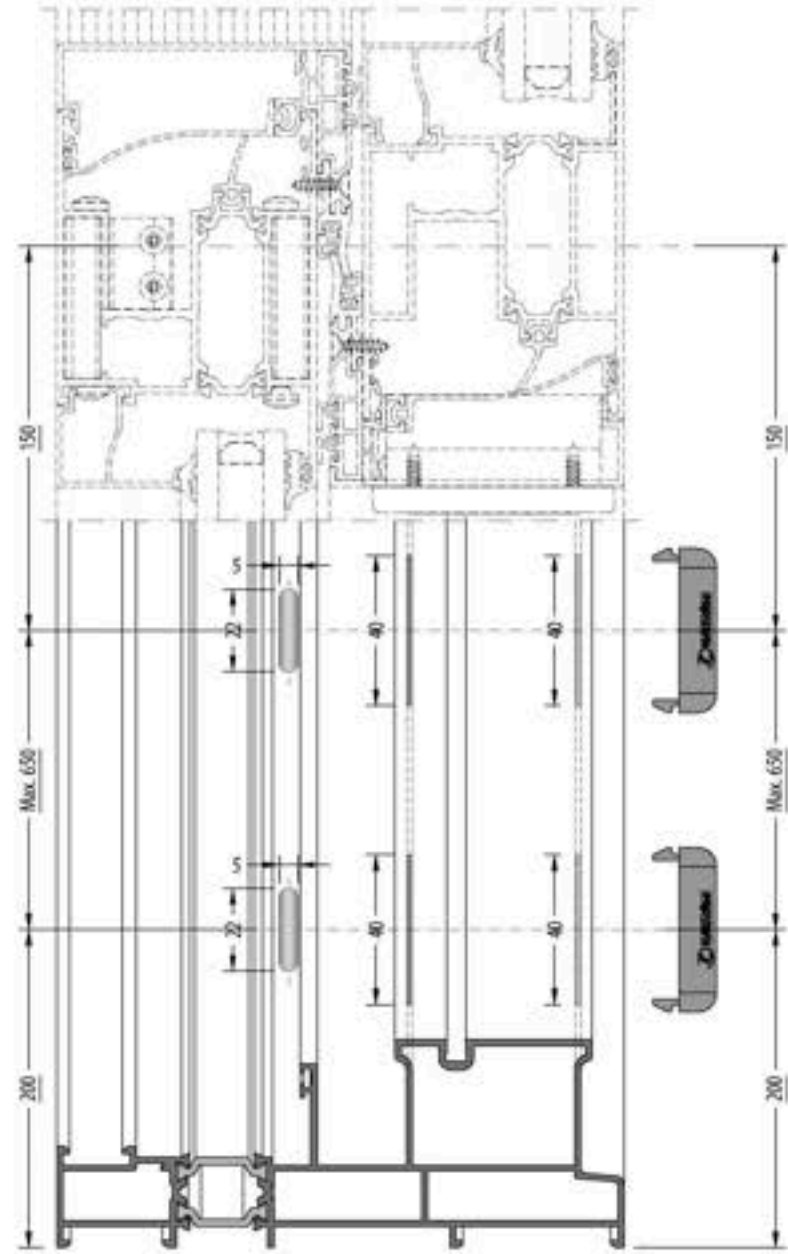

SASH ASSEMBLY / KANAT UYGULAMA

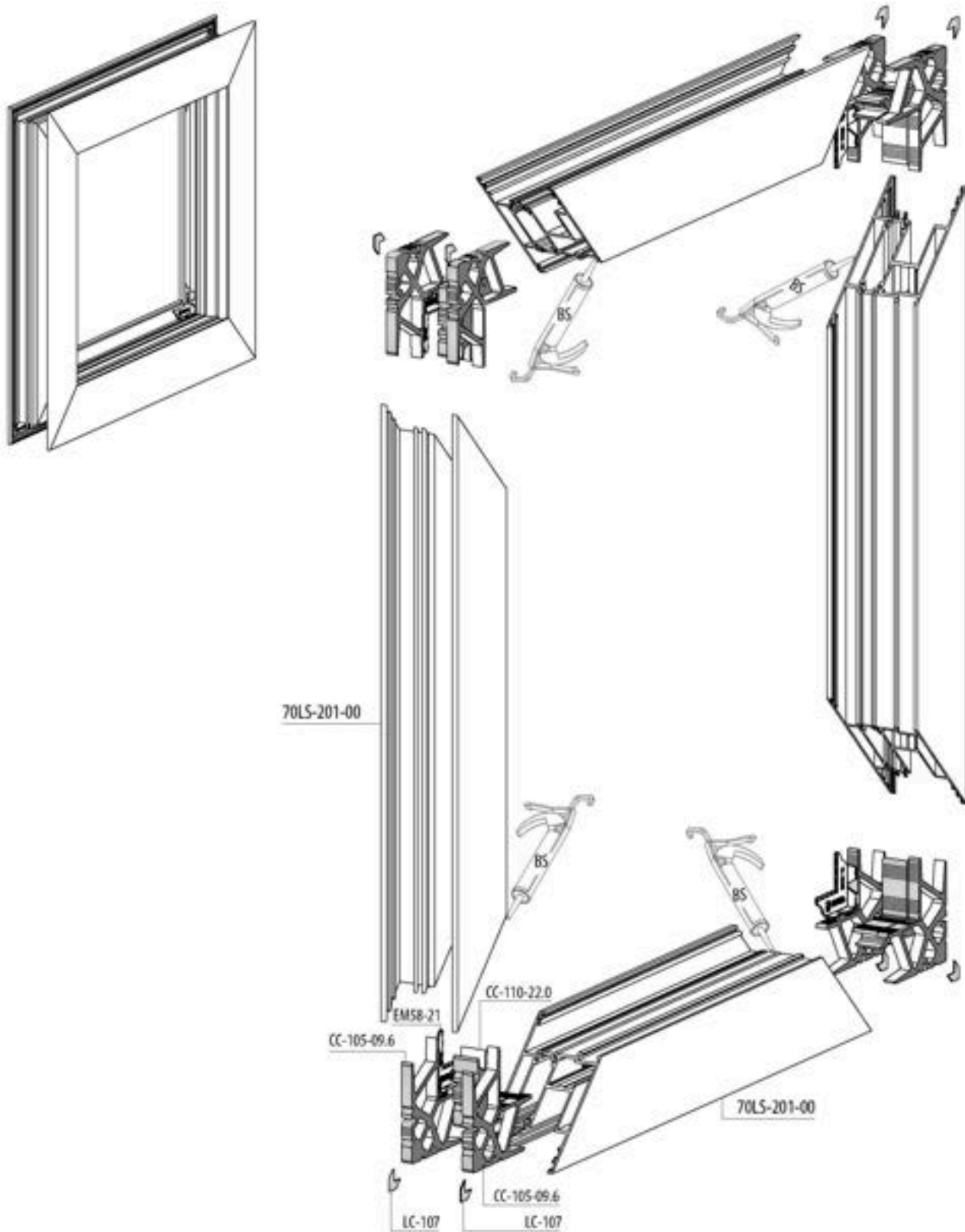

 S = SILICONE SİLİKON
 ES = EPDM BOND / EPDM YAPISIZI
 BS = BOND AND SEAL / YAPISIZI VE SIZDIRMAZ

SASH DRAINAGE HOLES / KANAT TAHLİYE DELİKLERİ

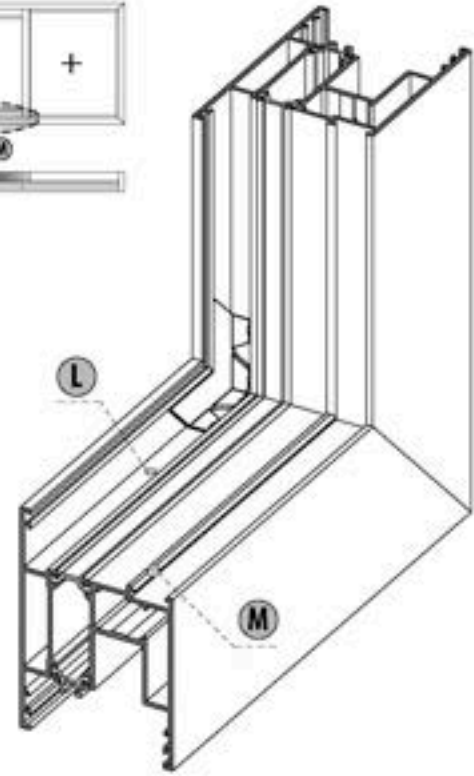
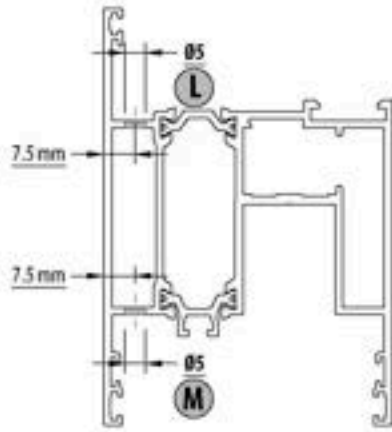
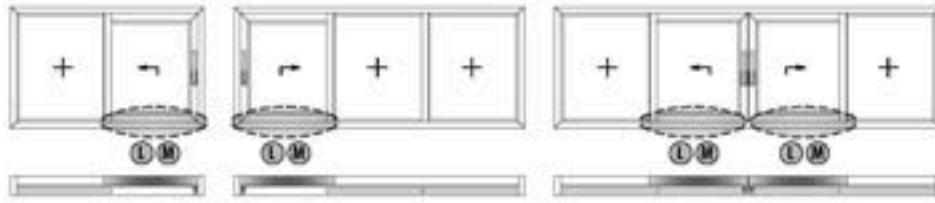

OPERATIONS / İŞLEMLER

- L** (70LS-201-00) Sash / Kanat
* Ø5 mm Hole / Delik
- M** (70LS-201-00) Sash / Kanat
* Ø5 mm Hole / Delik

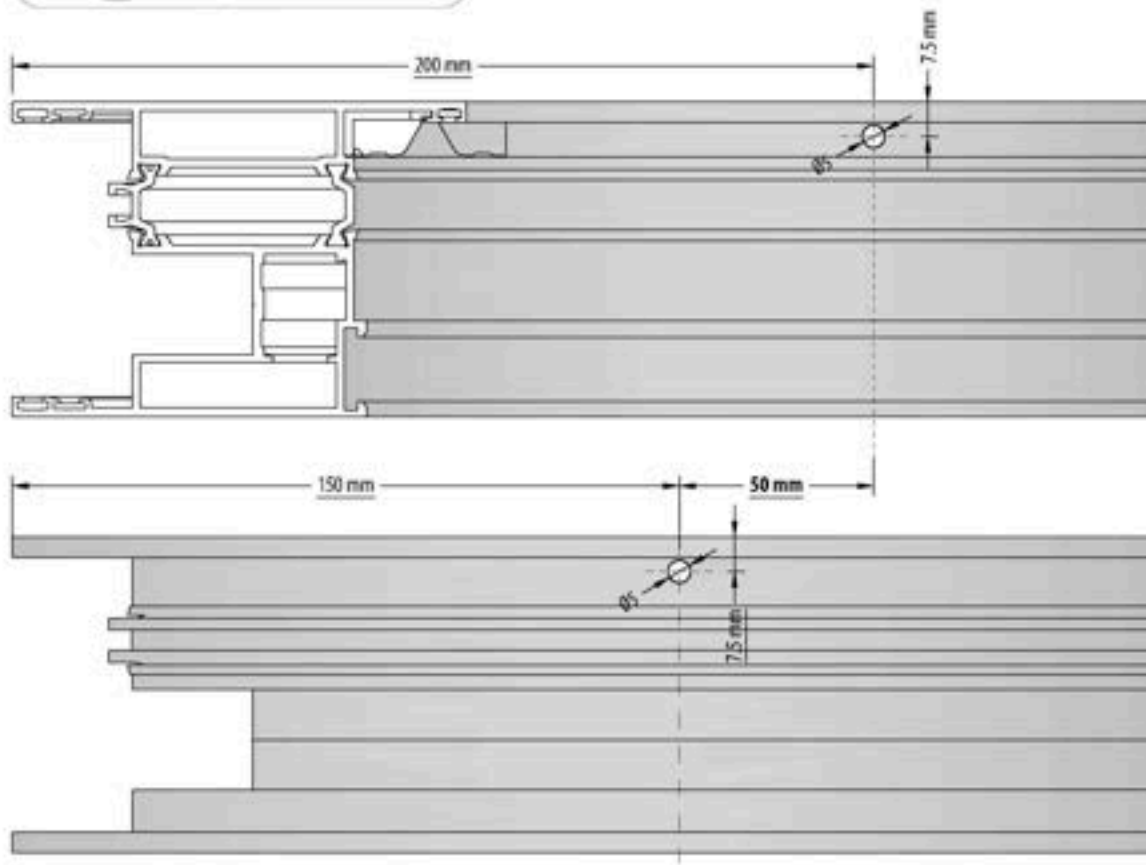

SASH AERATION HOLES / KANAT HAVALANDIRMA DELİKLERİ

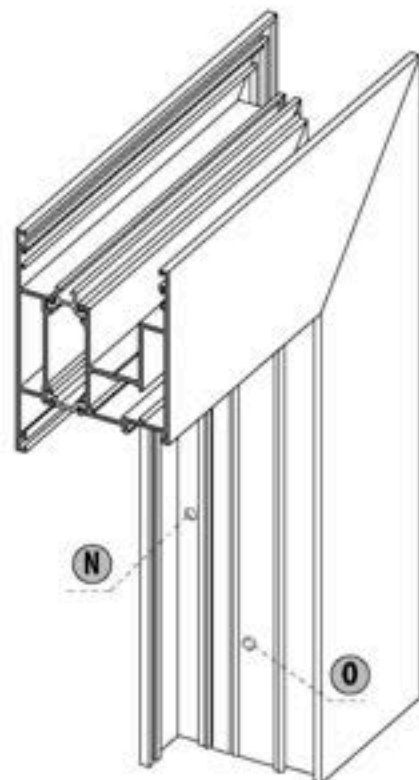
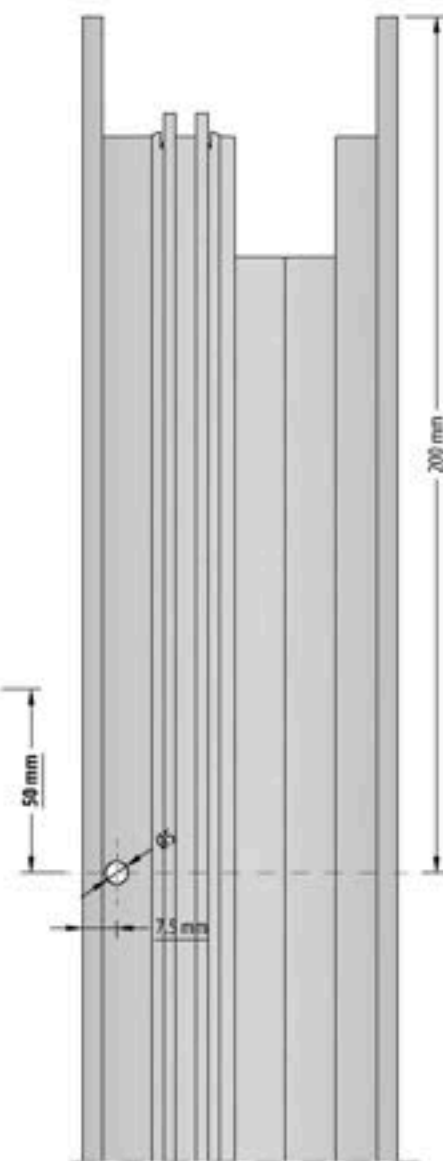
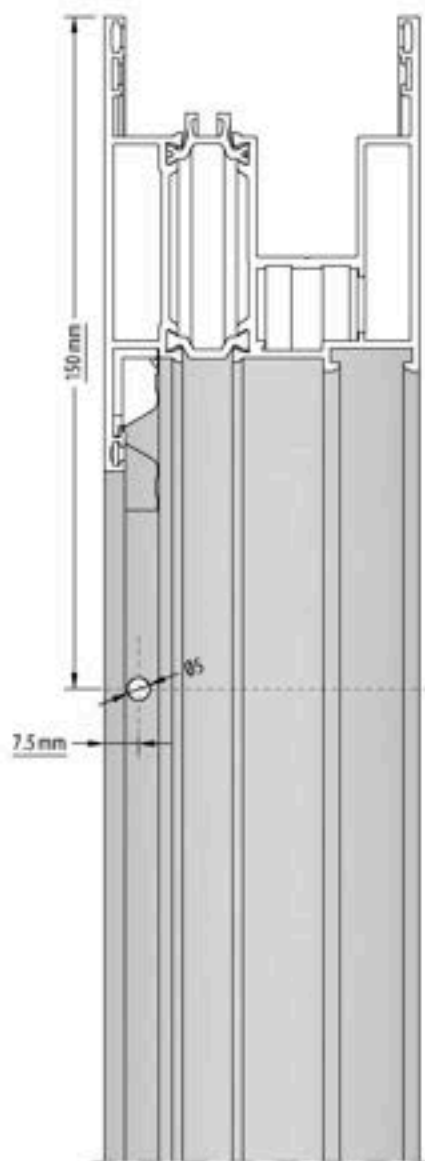
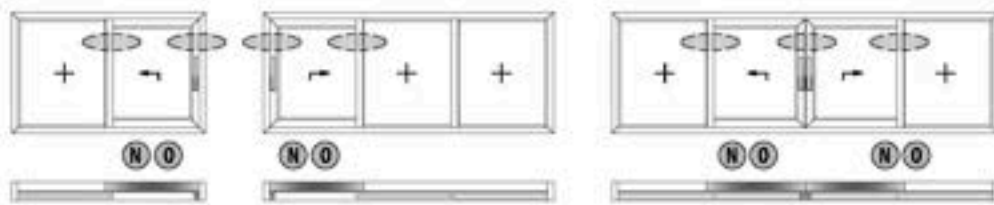

OPERATIONS / İŞLEMLER

- N** (70LS-201-00) Sash / Kanat
* Ø5 mm Hole / Delik
- O** (70LS-201-00) Sash / Kanat
* Ø5 mm Hole / Delik

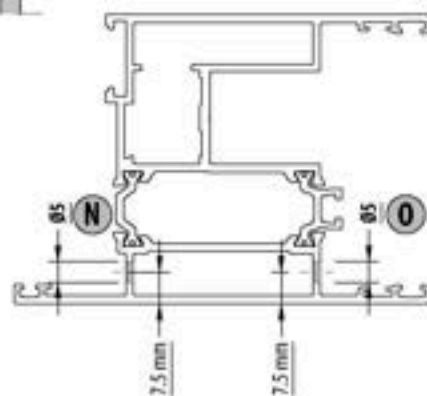

MULLION PROFILE ASSEMBLY / ORTA KAYIT PROFİL MONTAJI

70LS-302-00

A

NOTCH / KERTME

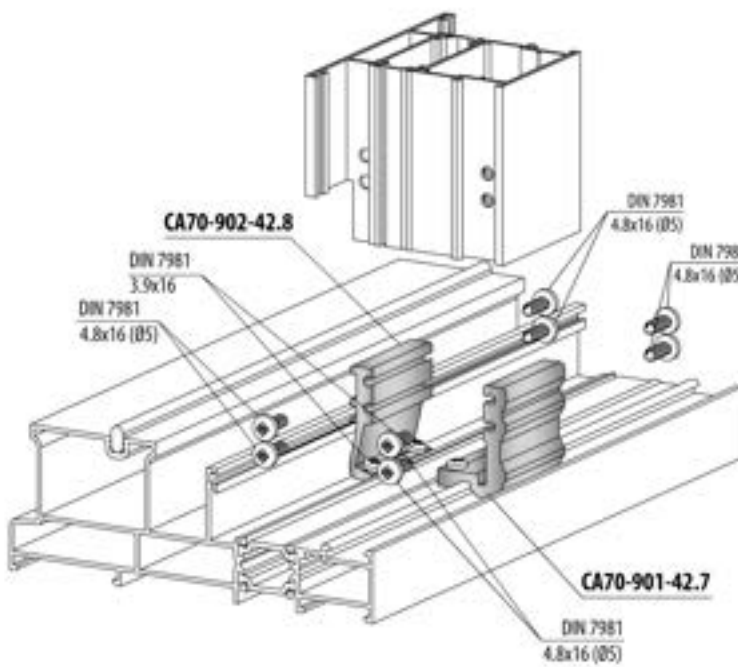
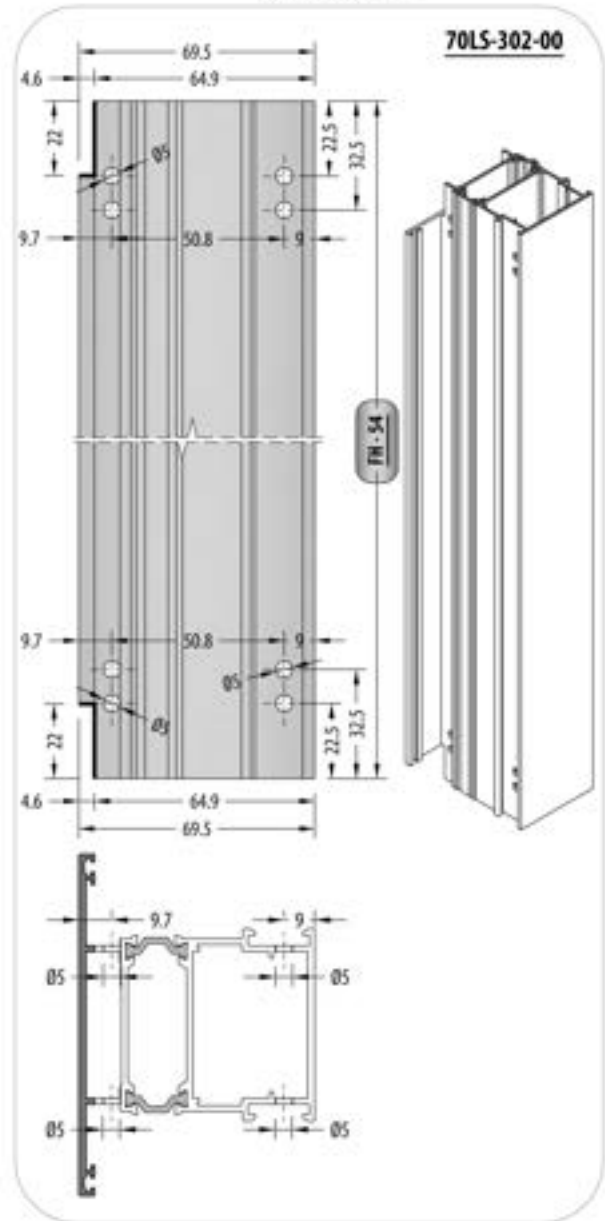
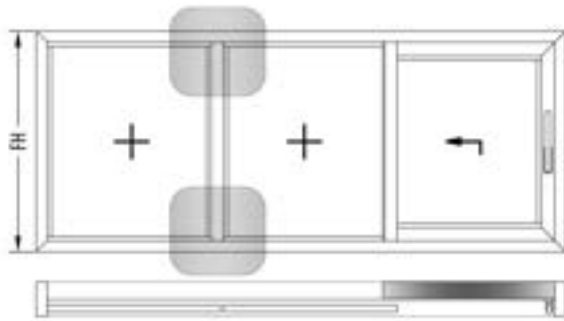

Isolation Before Montage
Montaj Öncesi İzolasyon



Isolation After Montage
Montaj Sonrası İzolasyon

MULLION PROFILE ASSEMBLY / ORTA KAYIT PROFİL MONTAJI

70LS-201-00

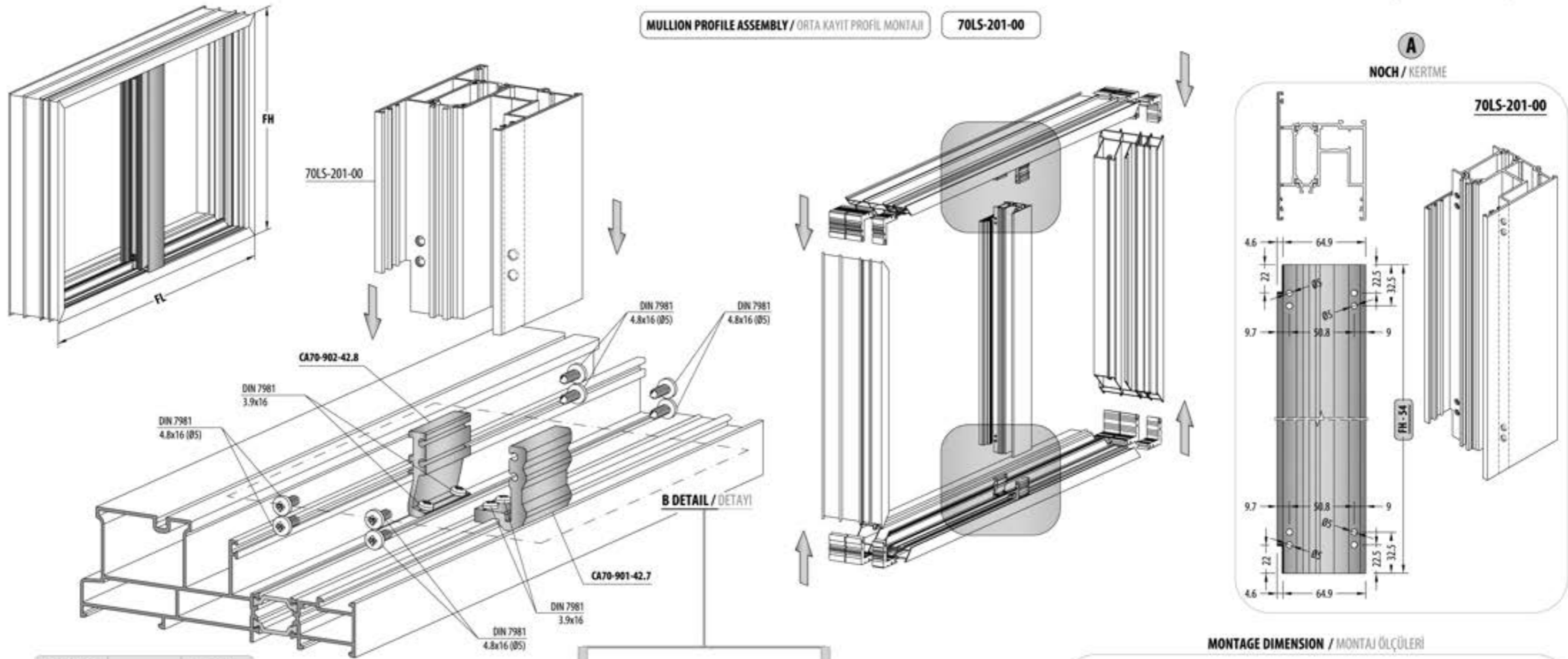

PACKAGE CODE PAKET KODU	DRAWING / ÇİZİM	CUTTING SIZE BETİM ÖLÇÜSÜ
CA70-901-42.8		42.8 mm
CC70-902-42.8		42.8 mm

OPERATIONS / İŞLEMLER

- A** 70LS-201-00
Mullion Profile Notch and Holes
Orta Kayıt Profili Kertme ve Delik Delme
- B** CA70-901-42.8, CC70-902-42.8
T Junction Montage / Çektirme Bağlantı Montajı
70LS-201-00
Mullion Profile Montage
Orta Kayıt Profili Montajı

S = SILICONE / SİLİKON
ES = EPDM BOND / EPDM YAPıştırıcı
BS = BOND AND SEAL / YAPıştırıcı VE SIZDIRMAZ

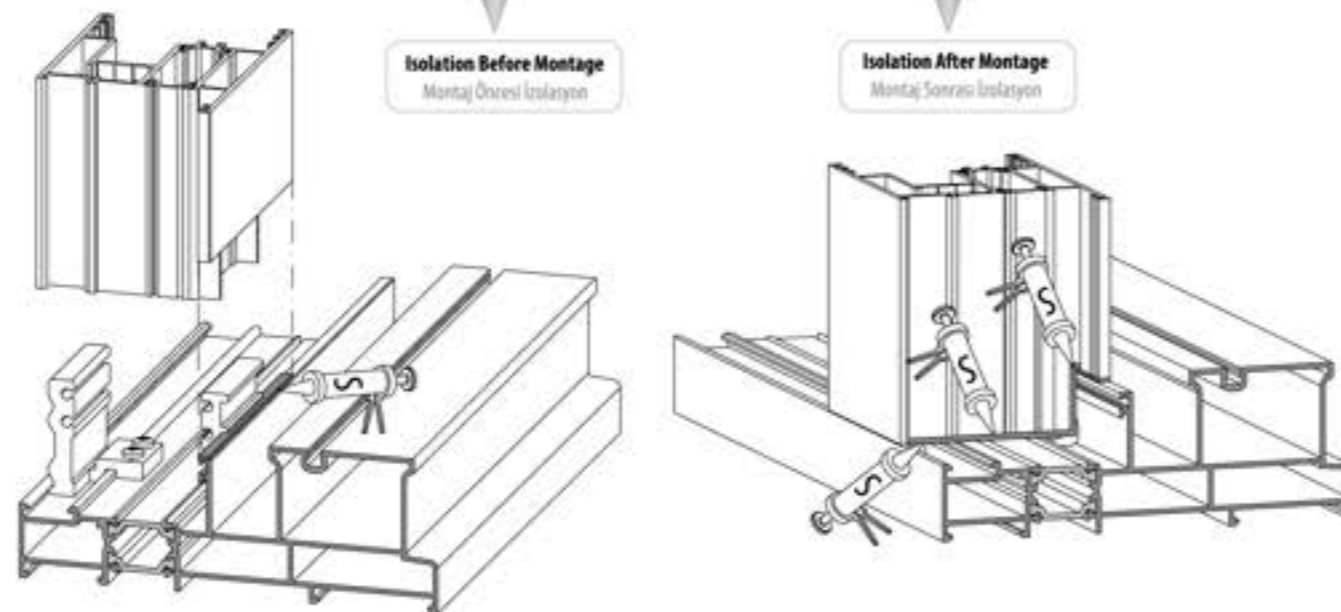

MONTAGE DIMENSION / MONTAJ ÖLÇÜLERİ

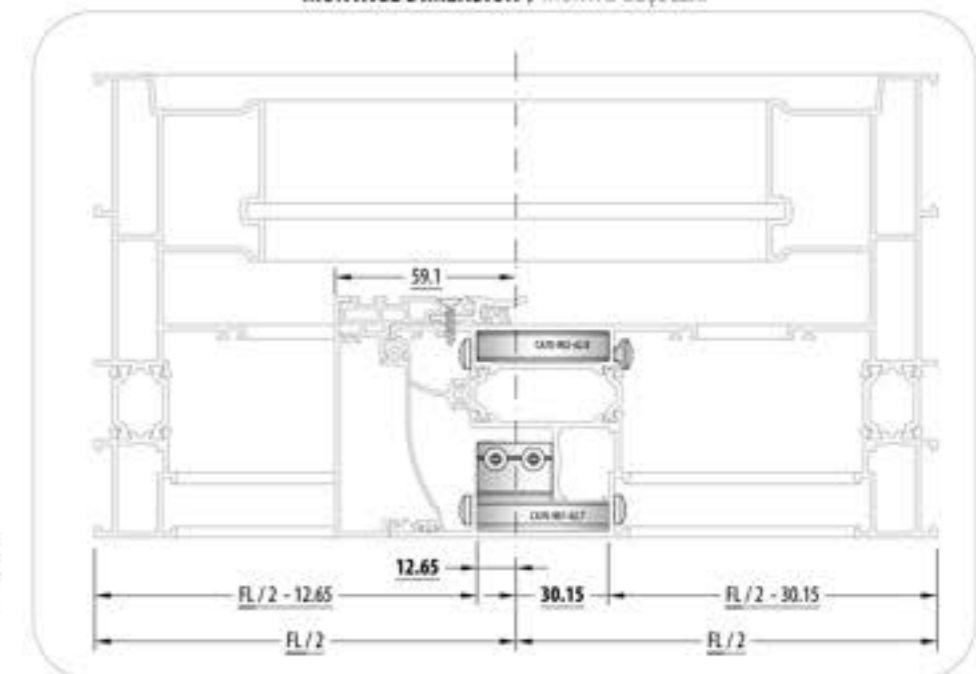

WEATHER STRIP MONTAGE / HAVA KESİCİ MONTAJI

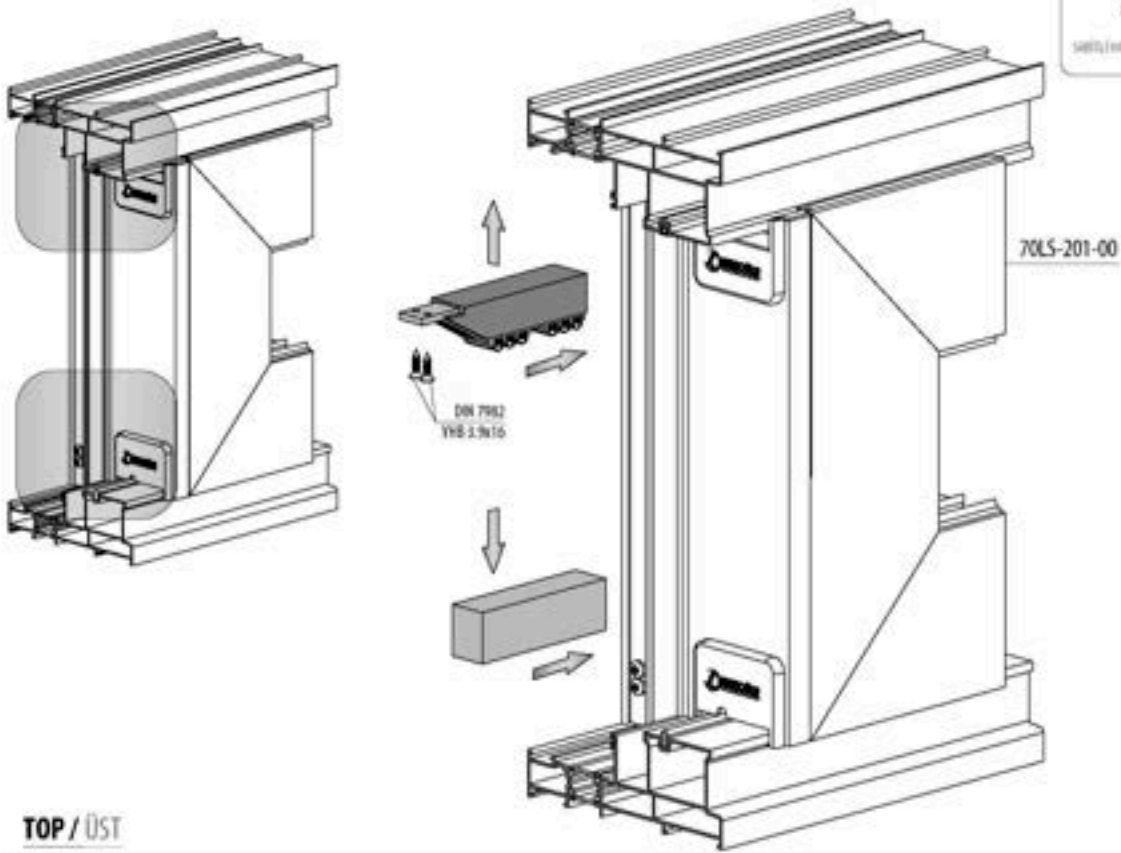

TOP / ÜST

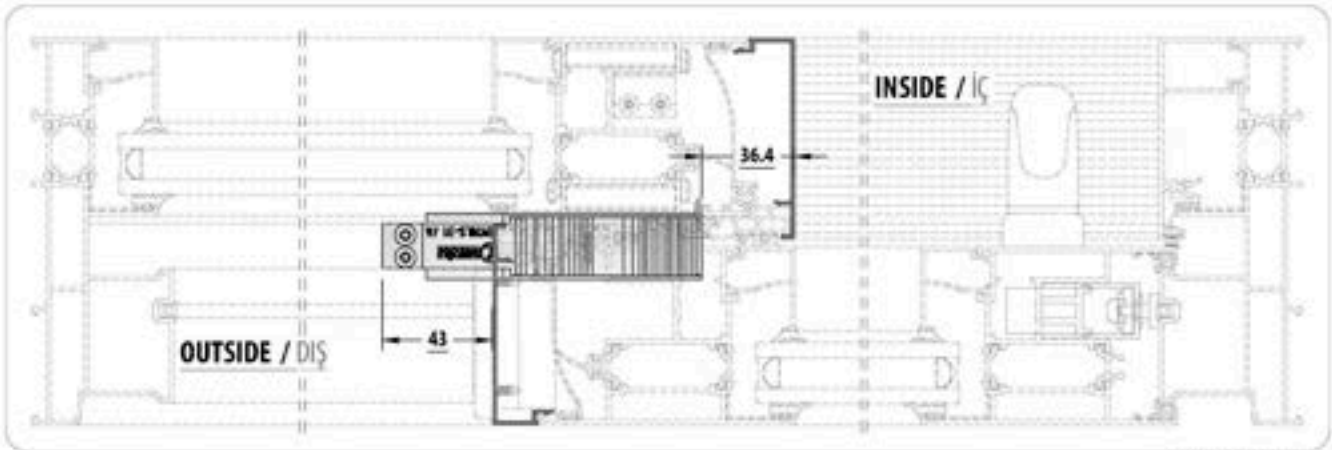

BOTTOM / ALT

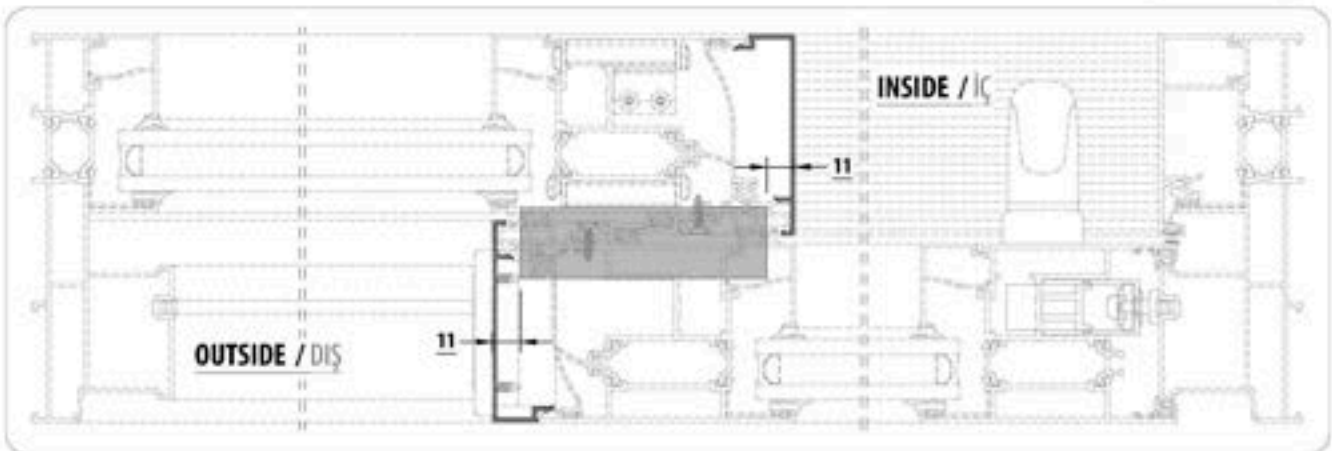

MONTAGE DIMENSION / MONTAJ ÖLÇÜLERİ

FIXED CLAMP PROFILE ASSEMBLY / SABİT KENET PROFİL MONTAJI

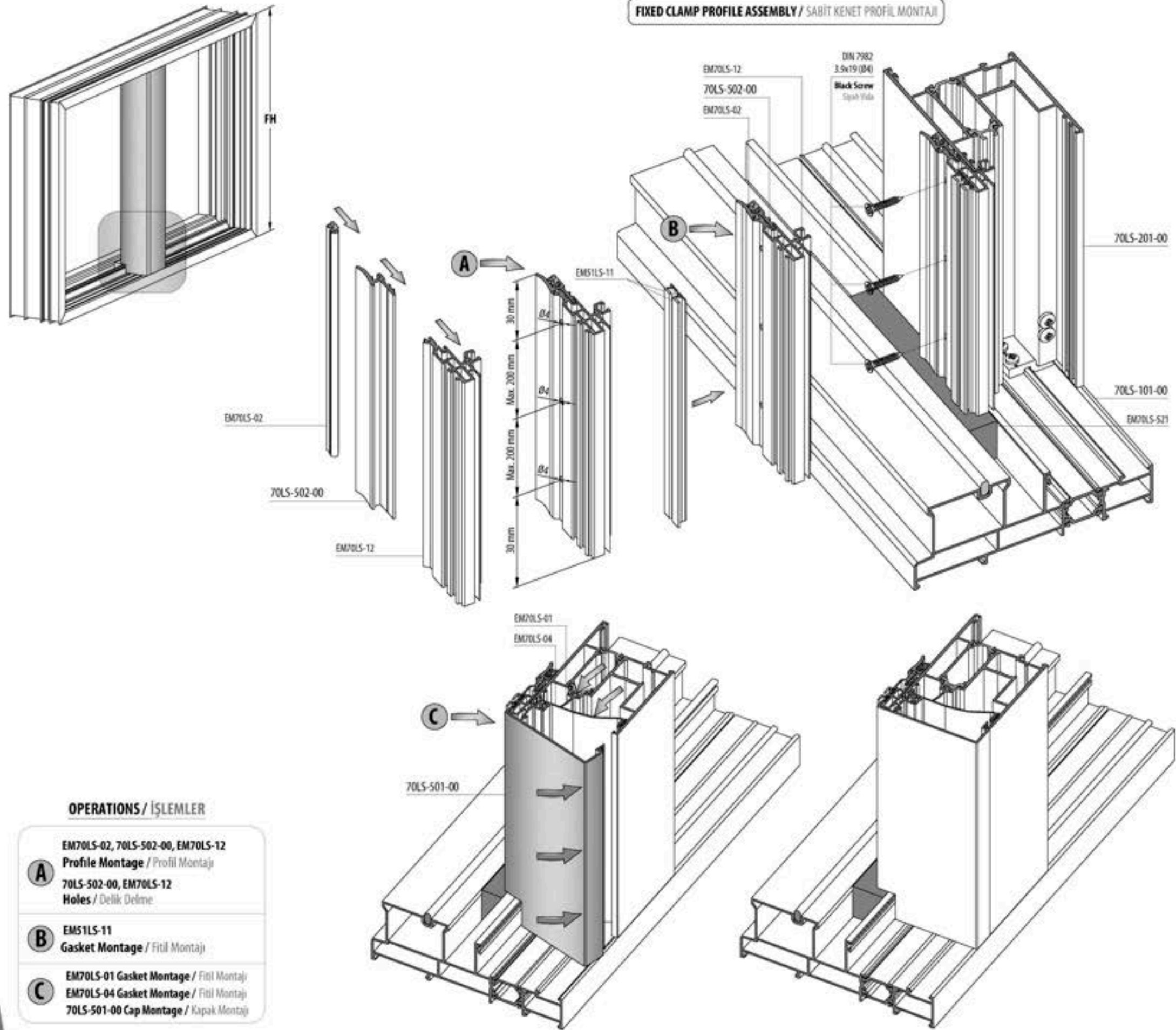

B HOLES / DELİK DELME

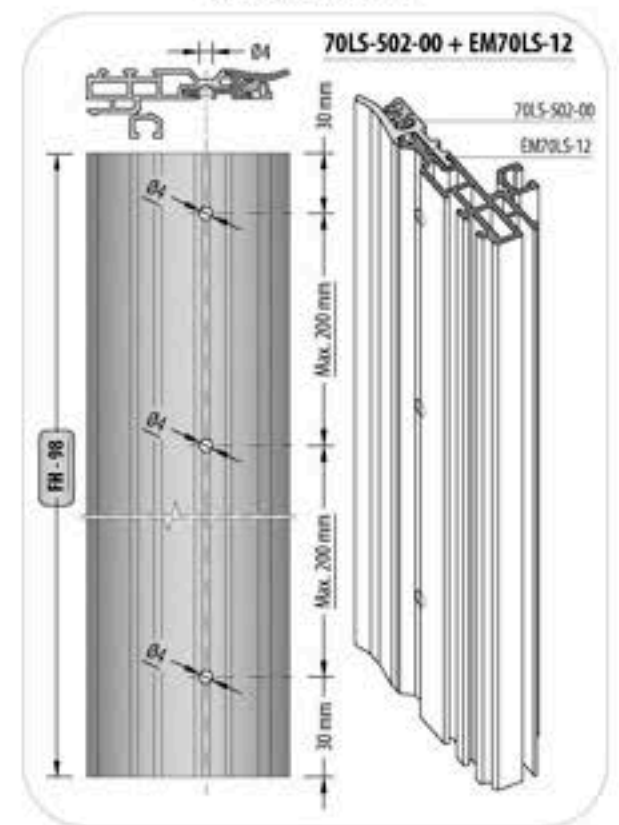

C NOCH / KERTME

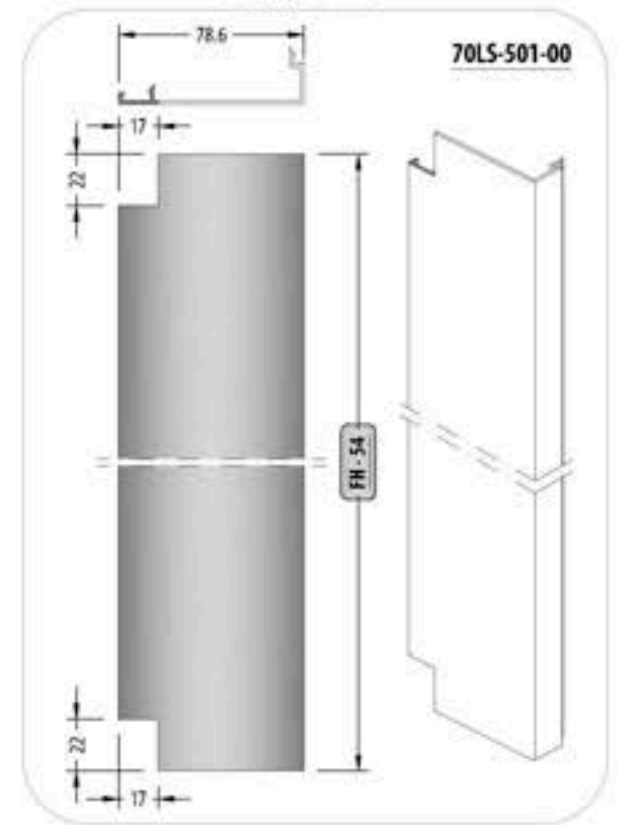

OPERATIONS / İŞLEMLER

- A** EM70LS-02, 70LS-502-00, EM70LS-12
Profile Montage / Profil Montajı
70LS-502-00, EM70LS-12
Holes / Delik Delme
- B** EM51LS-11
Gasket Montage / Filtül Montajı
- C** EM70LS-01 Gasket Montage / Filtül Montajı
EM70LS-04 Gasket Montage / Filtül Montajı
70LS-501-00 Cap Montage / Kapak Montajı

GLAZING BEAD PROFILE ASSEMBLY / CAM ÇITA PROFİL MONTAJI

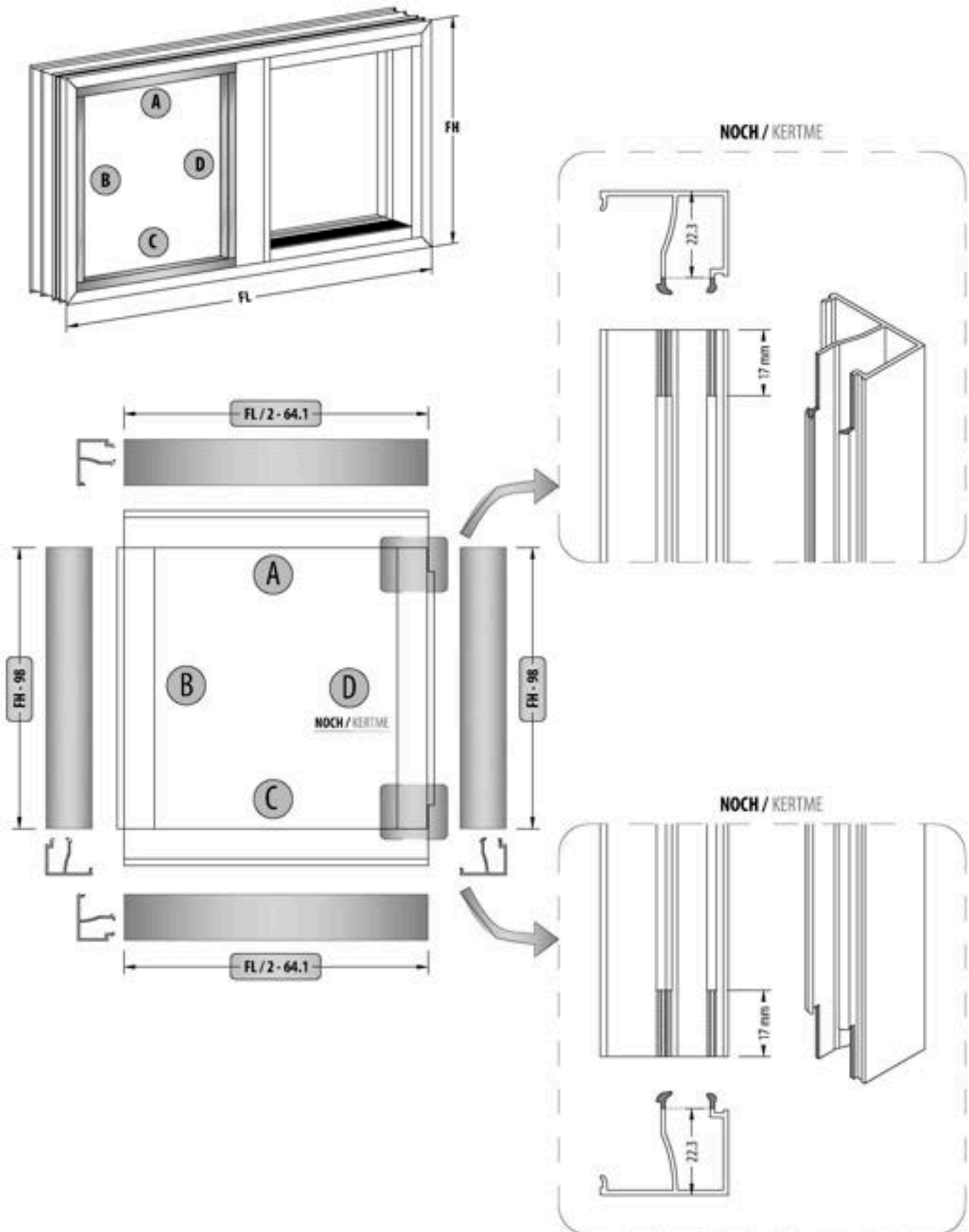

CAP PROFILE ASSEMBLY / KAPAK PROFİL MONTAJI

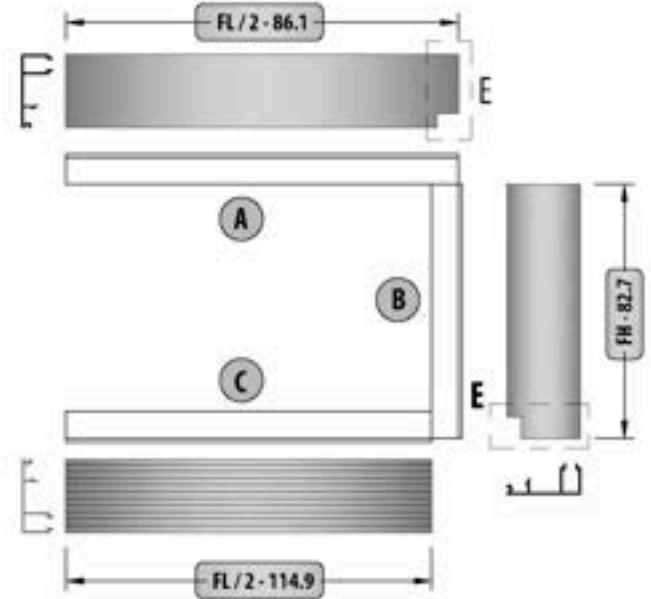
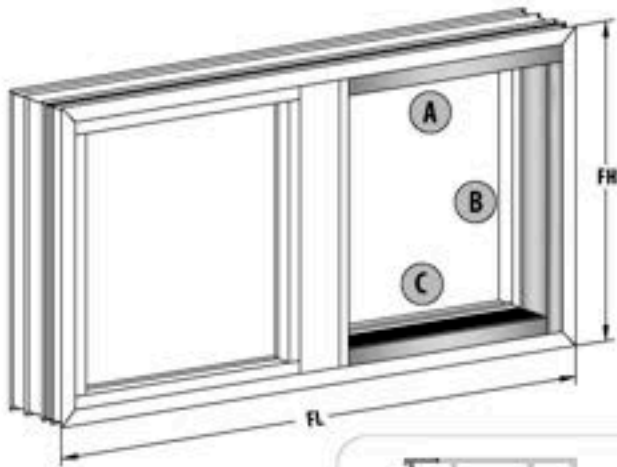

E
NOCH / KERTME

A B
CORNER DETAIL / KÖŞE DETAYI

B C
CORNER DETAIL / KÖŞE DETAYI

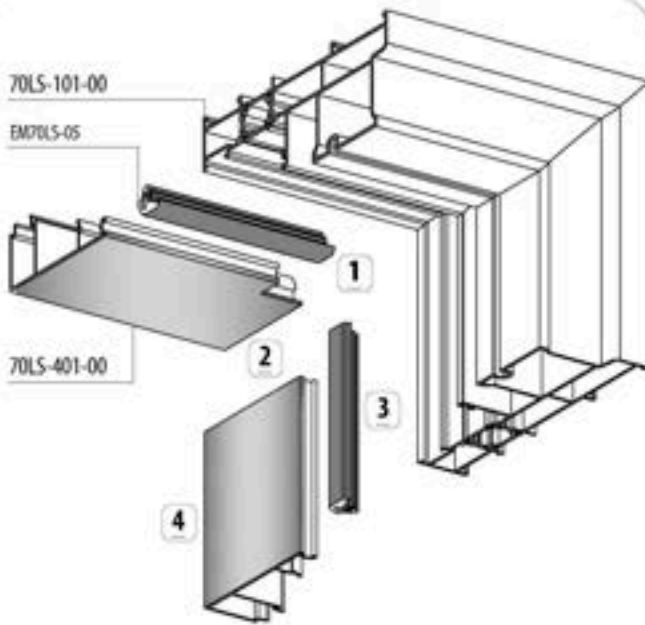

70LS-101-00

EM70LS-05

70LS-401-00

MONTAGE SEQUENCE
MONTAJ SIRASI

1/2/3/4

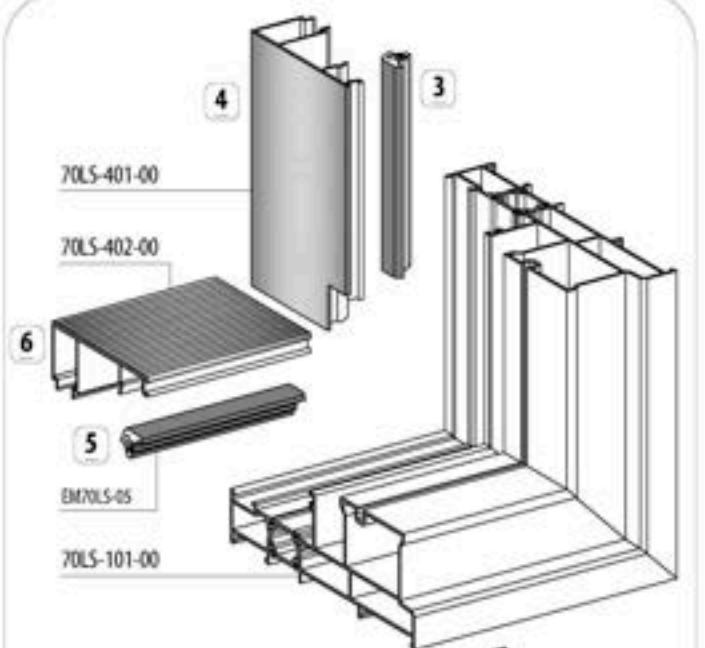

70LS-401-00

70LS-402-00

EM70LS-05

70LS-101-00

MONTAGE SEQUENCE
MONTAJ SIRASI

3/4/5/6



A

NOCH / KERTME

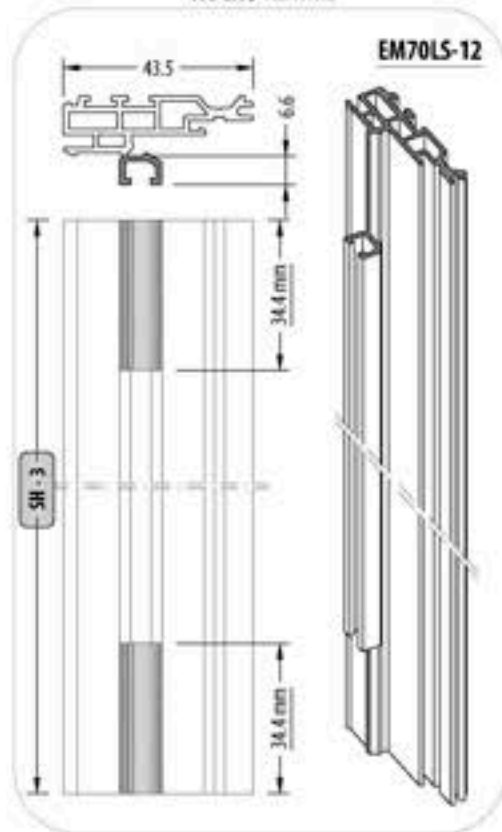

OPERATIONS / İŞLEMLER

- A** EM70LS-12
Pvc Adapter Noch / Pvc Adaptör Kertme
- B** EM70LS-02, 70LS-502-00, EM70LS-12
Profile Montage / Profil Montajı
- C** EM70LS-06
Brush Montage / Ferça Montajı
- D** 70LS-501-00 Cap Profile Noch / Kapak Profil Kertme
- E** EM70LS-01 Gasket Montage / Fıtlı Montajı
EM70LS-04 Gasket Montage / Fıtlı Montajı
70LS-501-00 Cap Profile Montage / Kapak Profil Montajı

SASH CLAMP PROFILE ASSEMBLY / KANAT KENET PROFİL MONTAJI

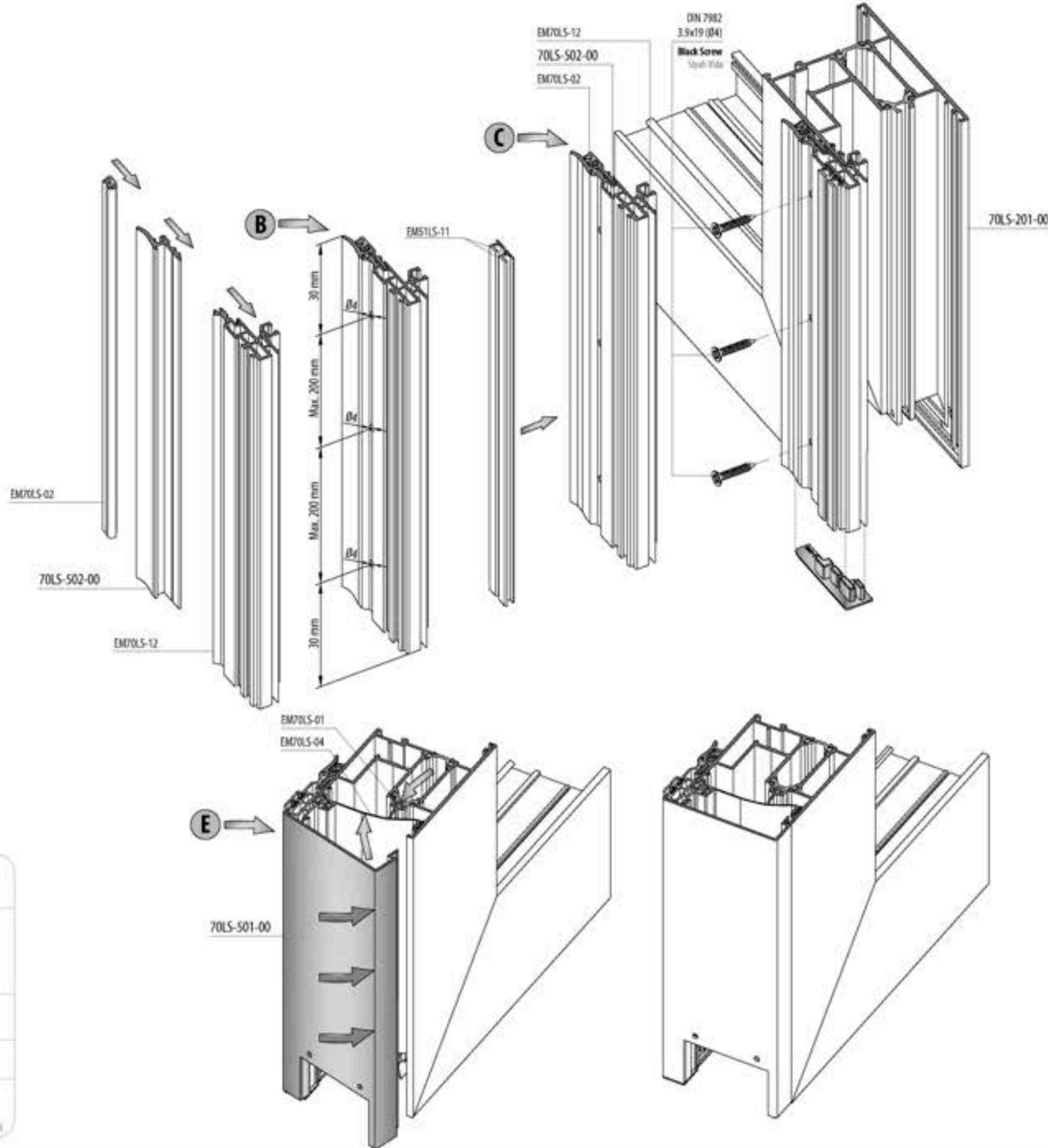

B

HOLES / DELİK DELME

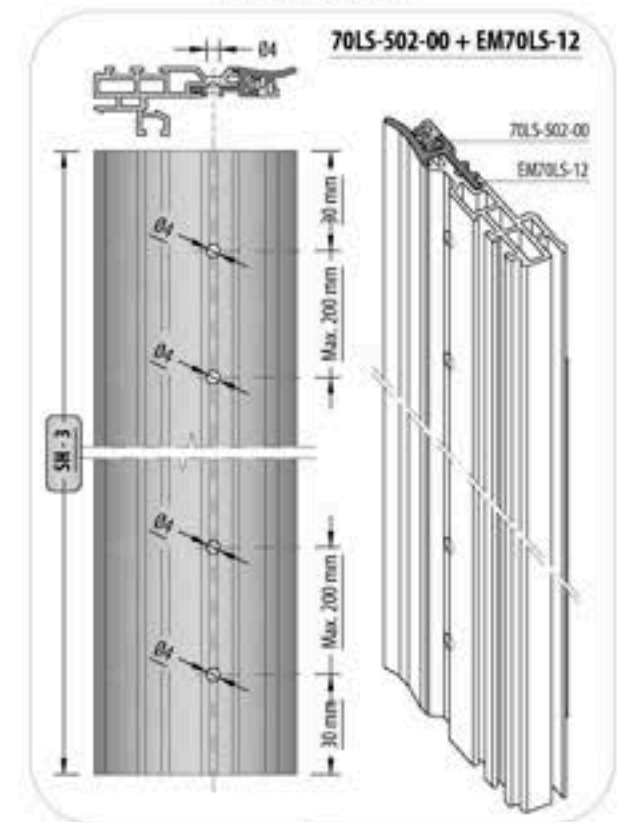

D

NOCH / KERTME

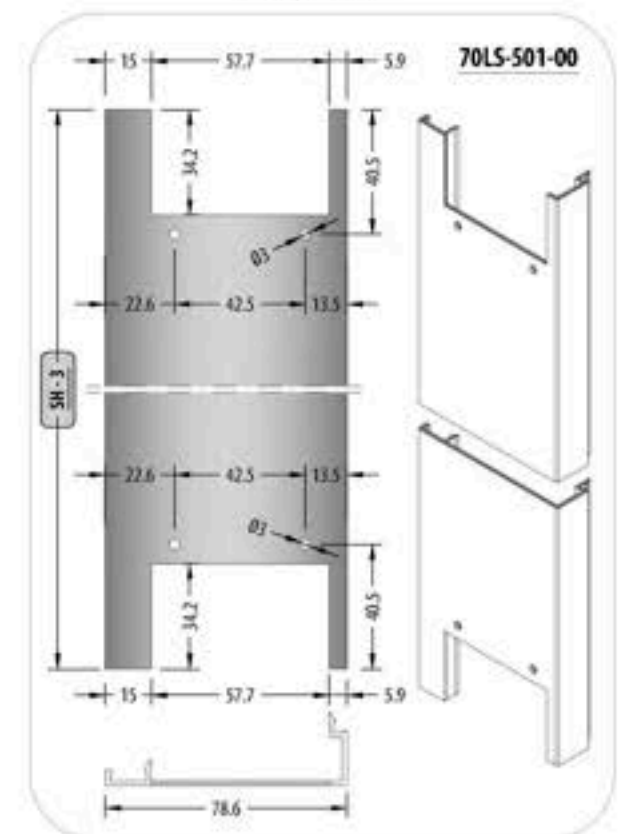

CLAMPING CAP ASSEMBLY / KENET KAPAK MONTAJI

EM70LS-201
CLAMPING
ACCESSORIES SET
KENET AKSESUAR TAKIMI

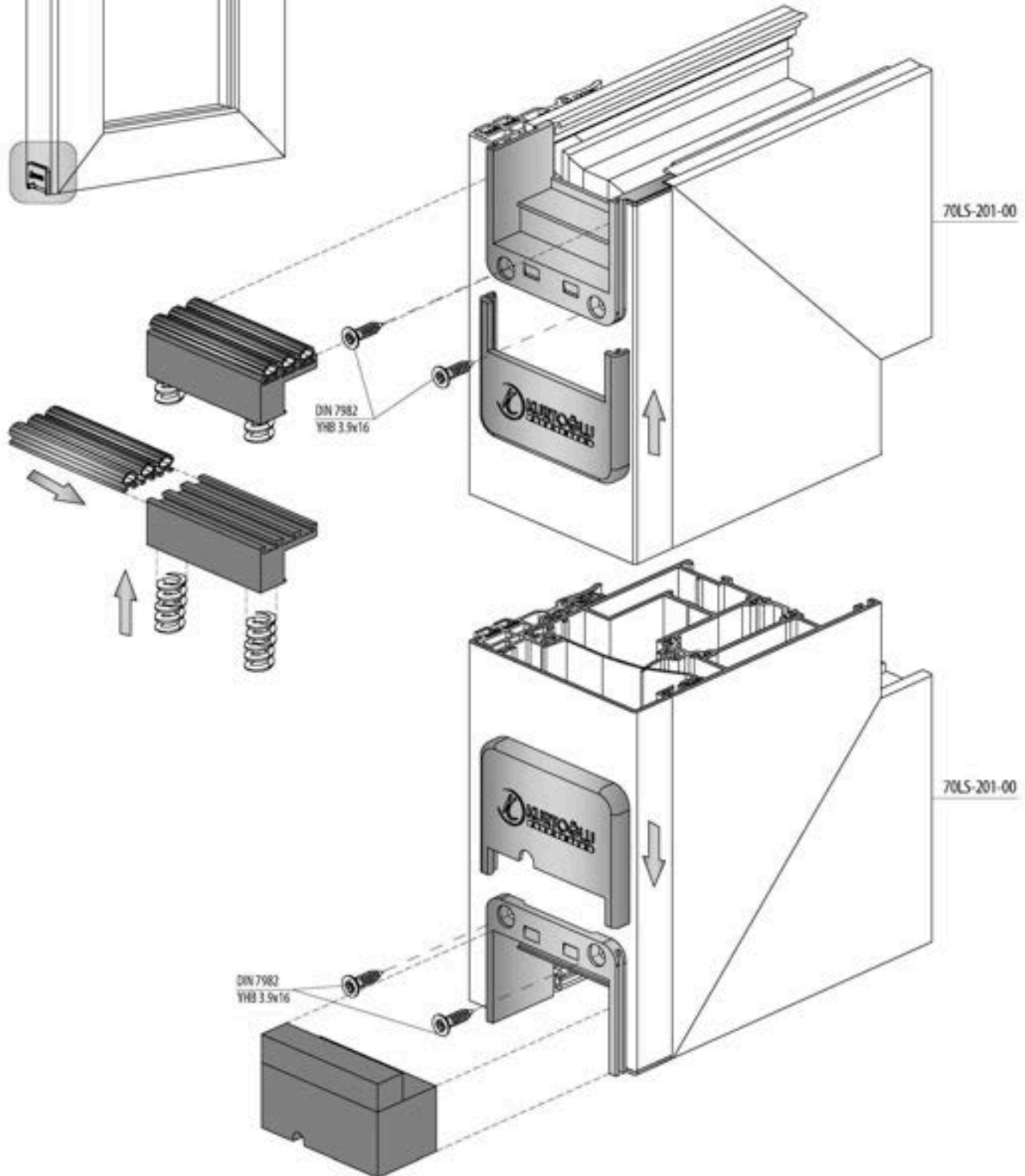
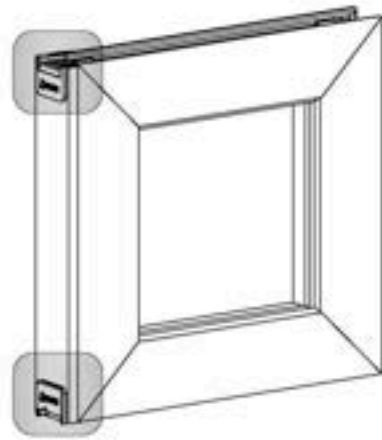

FRAME ASSEMBLY SCREW APPLICATION
KASA MONTAJ VIDA UYGULAMASI

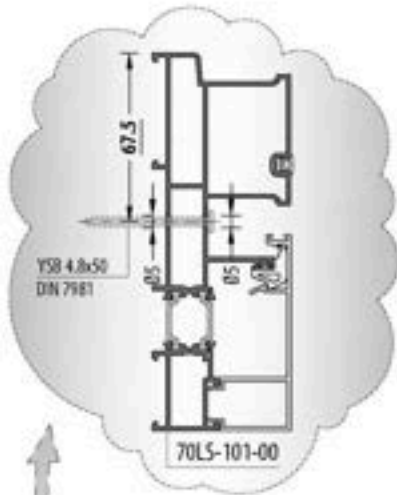

B
DETAIL / DETAYI

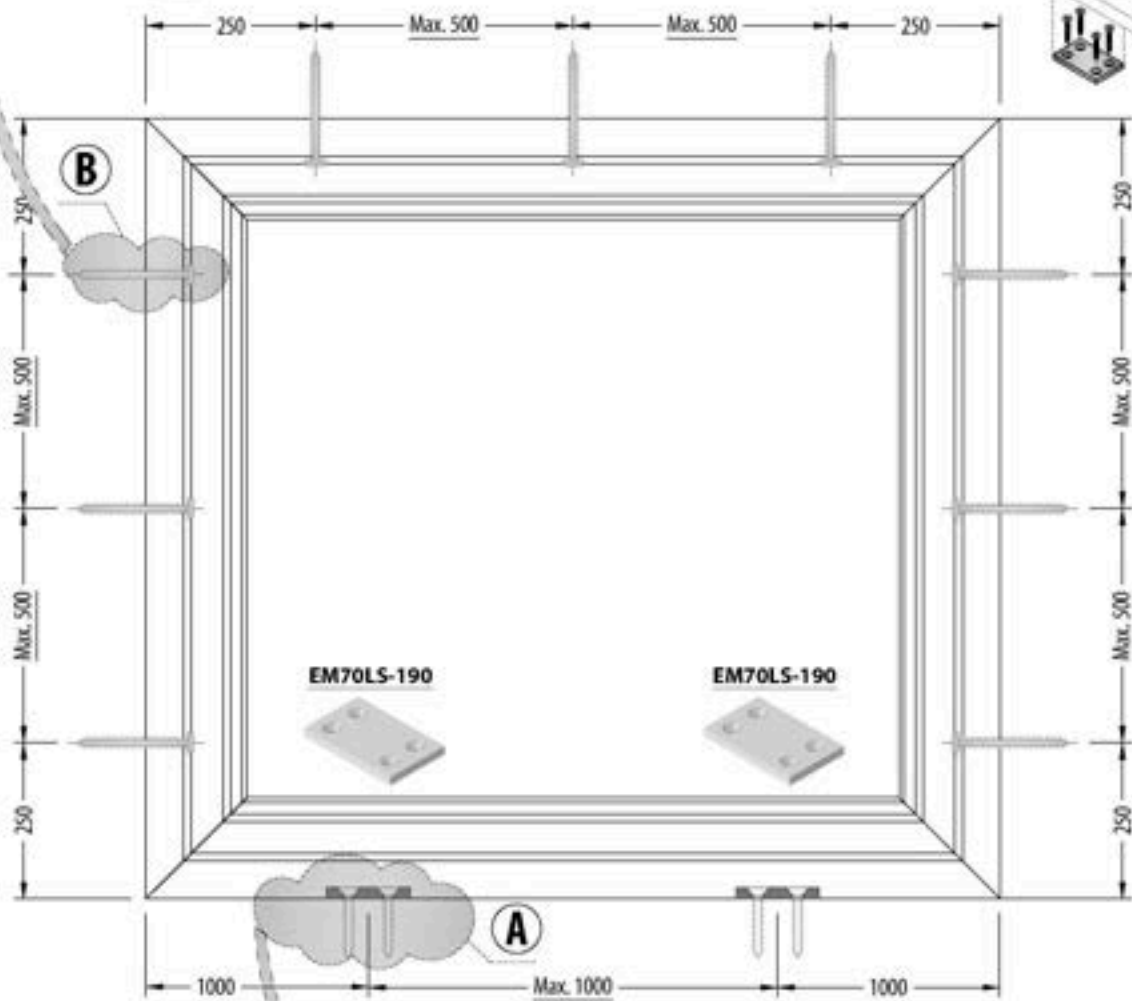
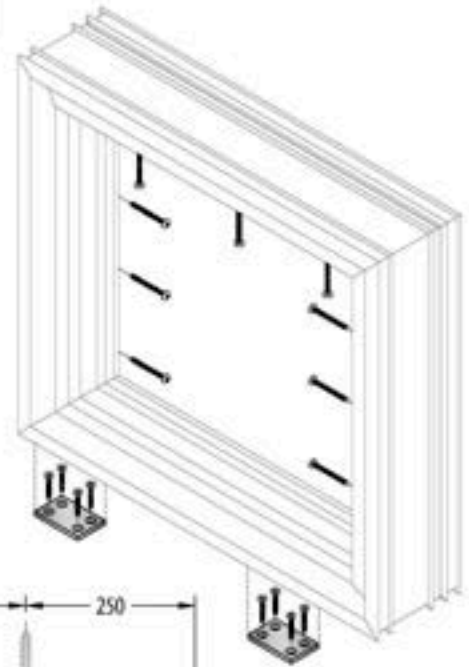

EM70LS-190

EM70LS-190

YHB 4.8x32
DIN 7982

A
DETAIL
DETAYI

EM70LS-190
FRAME MONTAGE
WEDGE
KASA MONTAJ TAKIZI



FRAME ASSEMBLY / KASA UYGULAMA

70LS-102-00

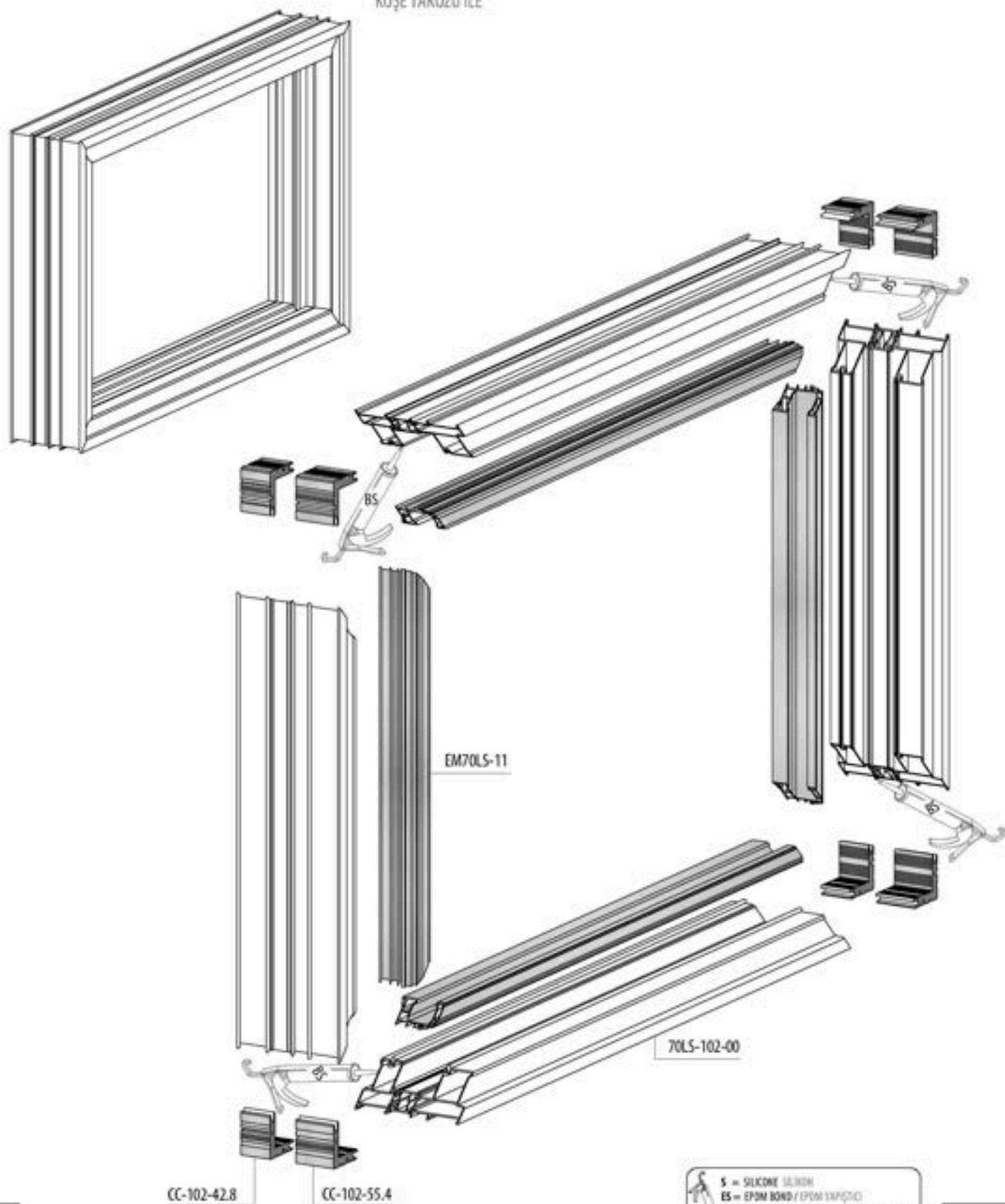
WITH PRES CORNER JOINT
KÖŞE TAKOZU İLE

CC-102-42.8

CC-102-55.4

S = SILKONE SİLİKON
 ES = EPDM BOND / EPDM YAPıştırıcı
 BS = BOND AND SEAL / YAPıştırıcı VE SİZİRMİYAZ

FRAME ASSEMBLY / KASA UYGULAMA

70LS-102-00



WITH
MECHANICAL
CORNER JOINT
MEKANİK KÖŞE
BAĞLANTI

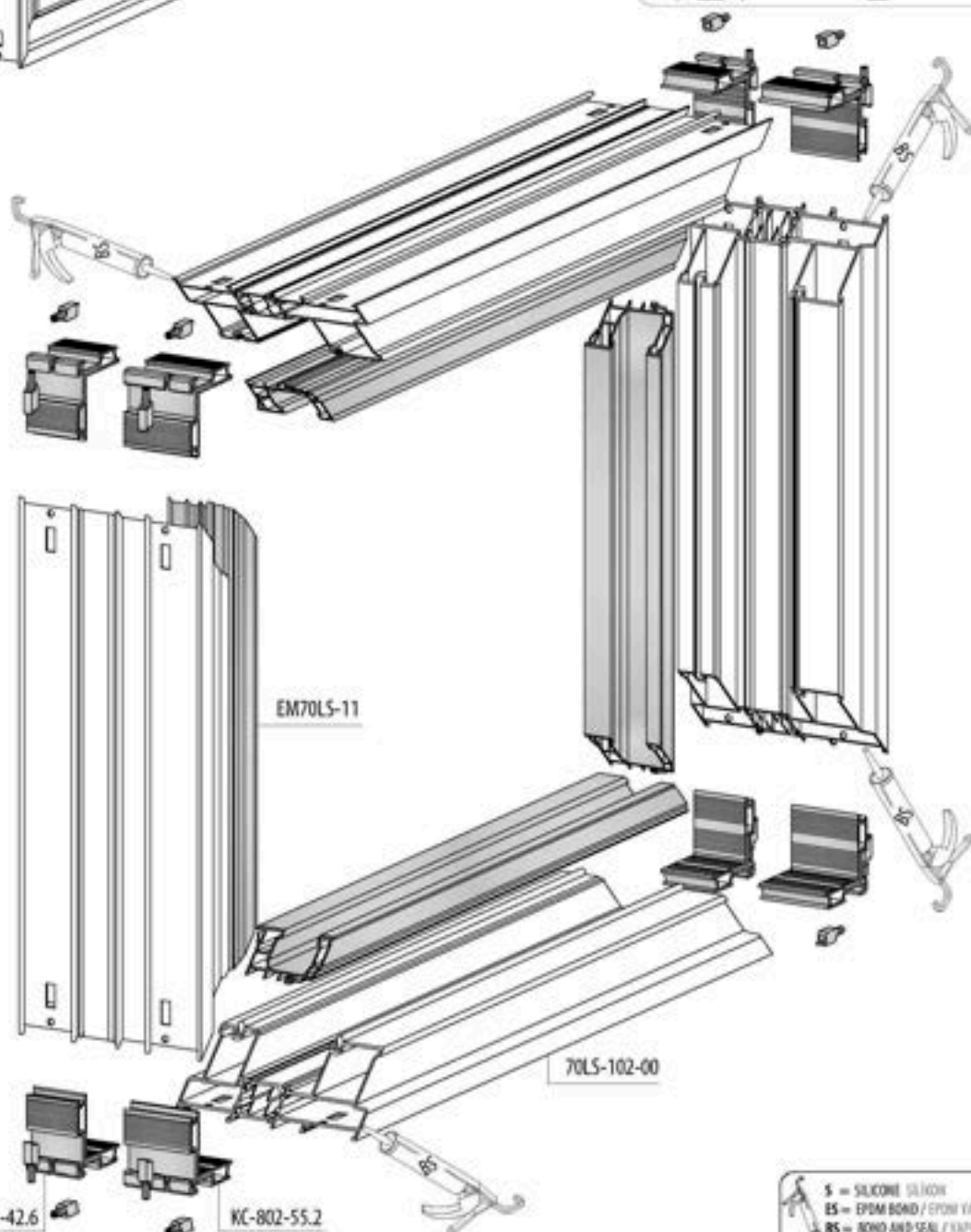
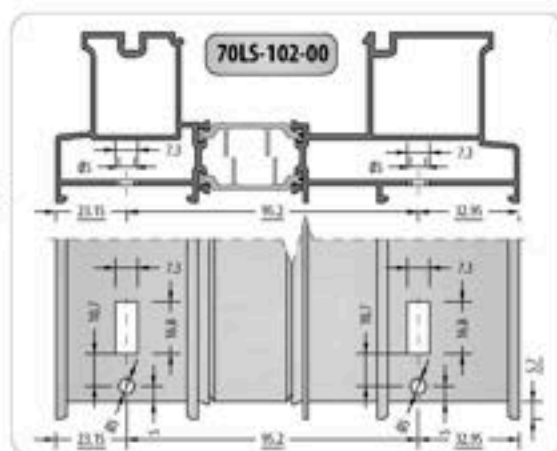

S = SILICONE SILIKON
ES = EPDM BOND / EPDM YAPISICI
BS = BOND AND SEAL / KAPATIRICI VE SIZDIRMAZ

PASSIVE SIDE DRAINAGE / PASİF TARAF TAHLİYE

70LS-102-00

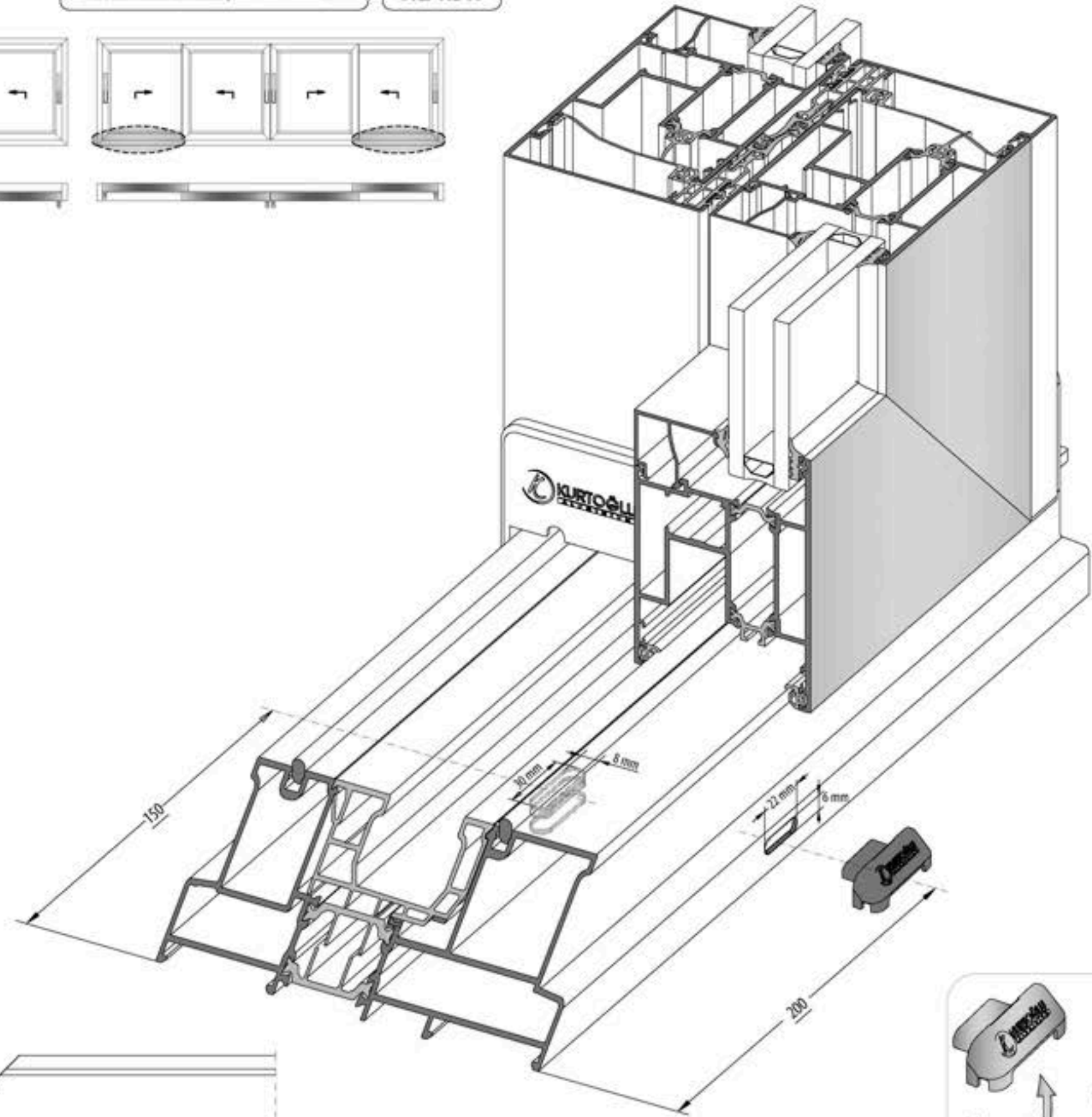
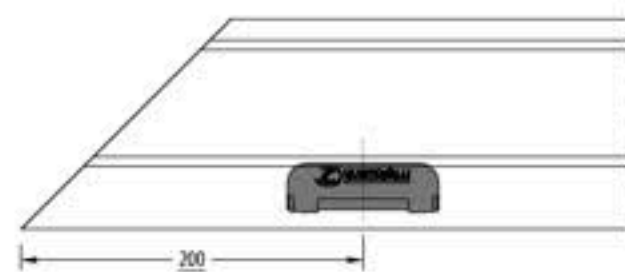
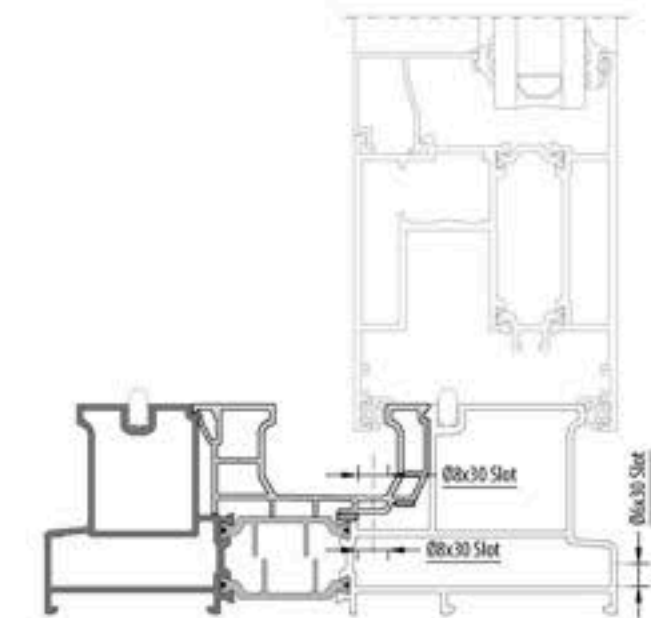
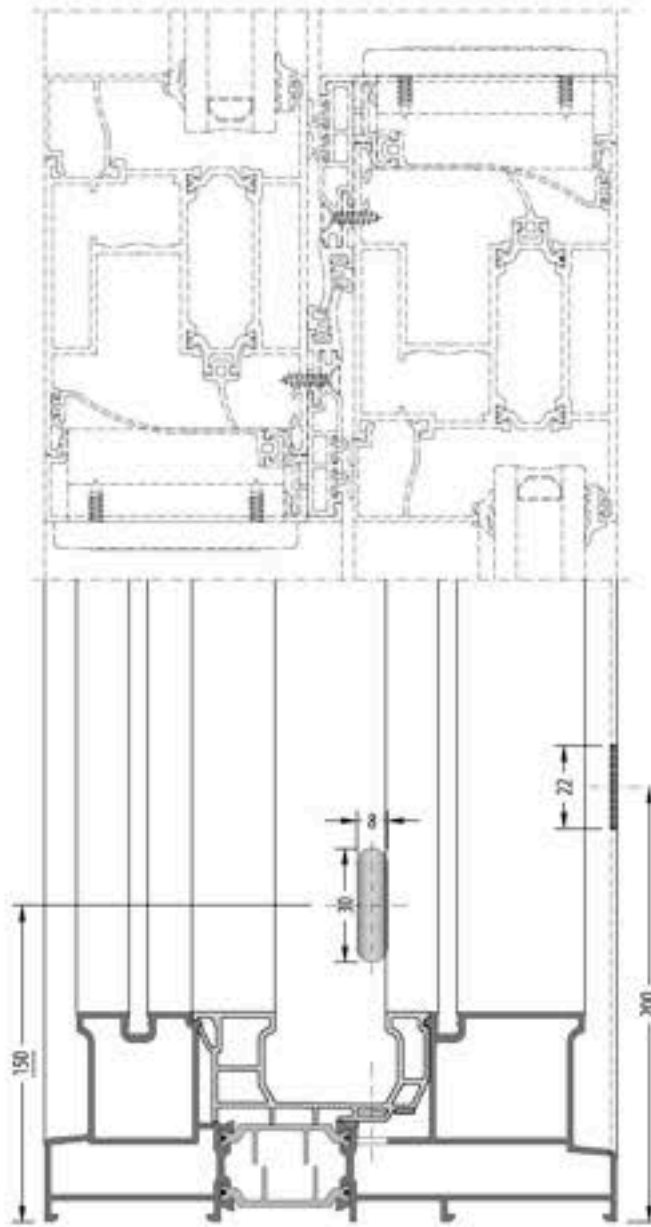
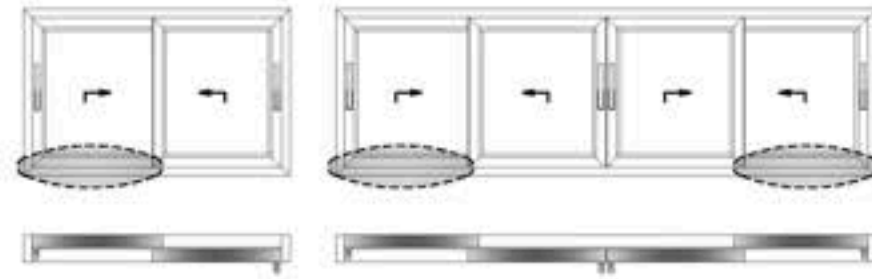

ACTIVE SIDE DRAINAGE / AKTİF TARAF TAHLİYE

70LS-102-00

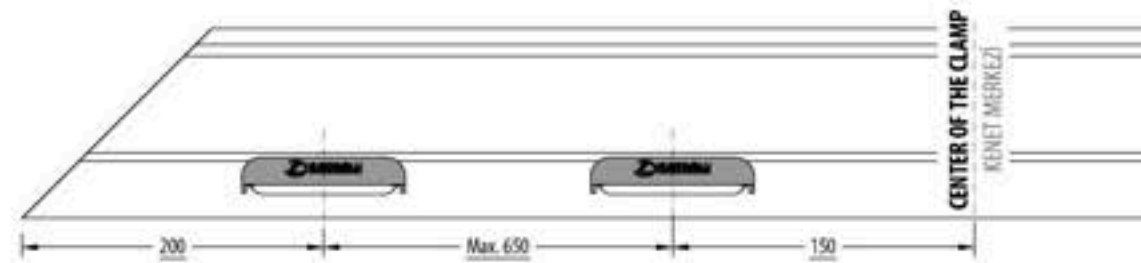
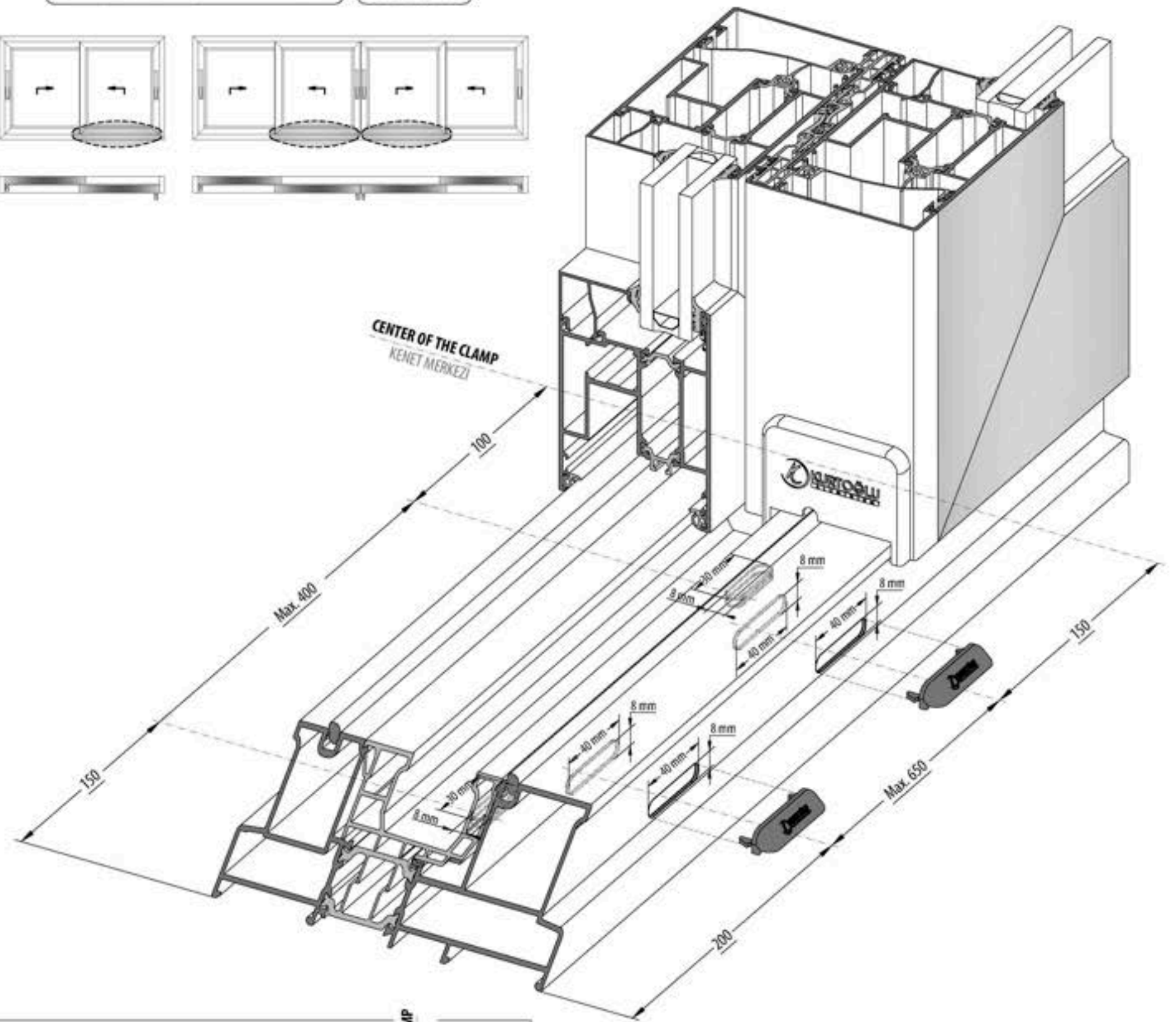
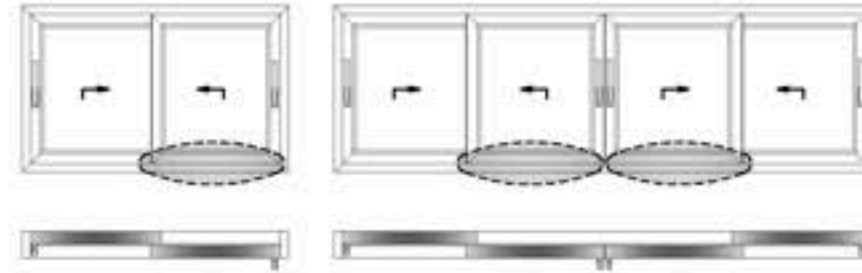
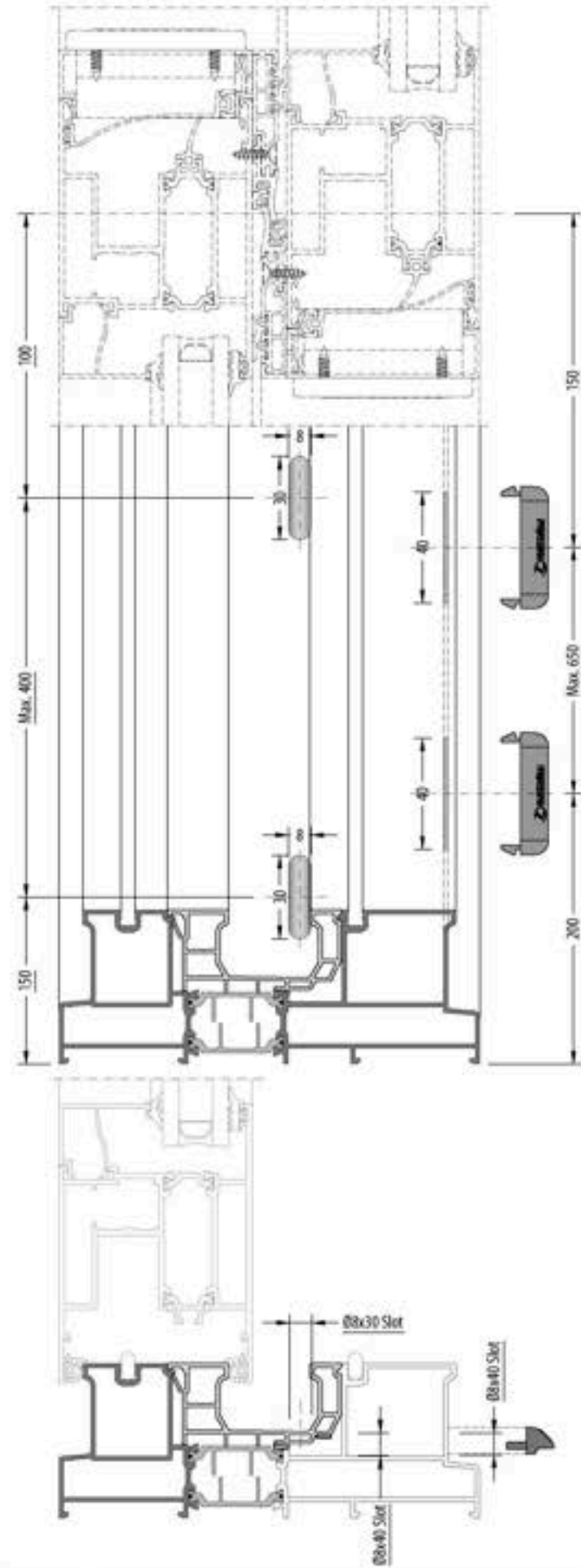

SASH ASSEMBLY / KANAT UYGULAMA

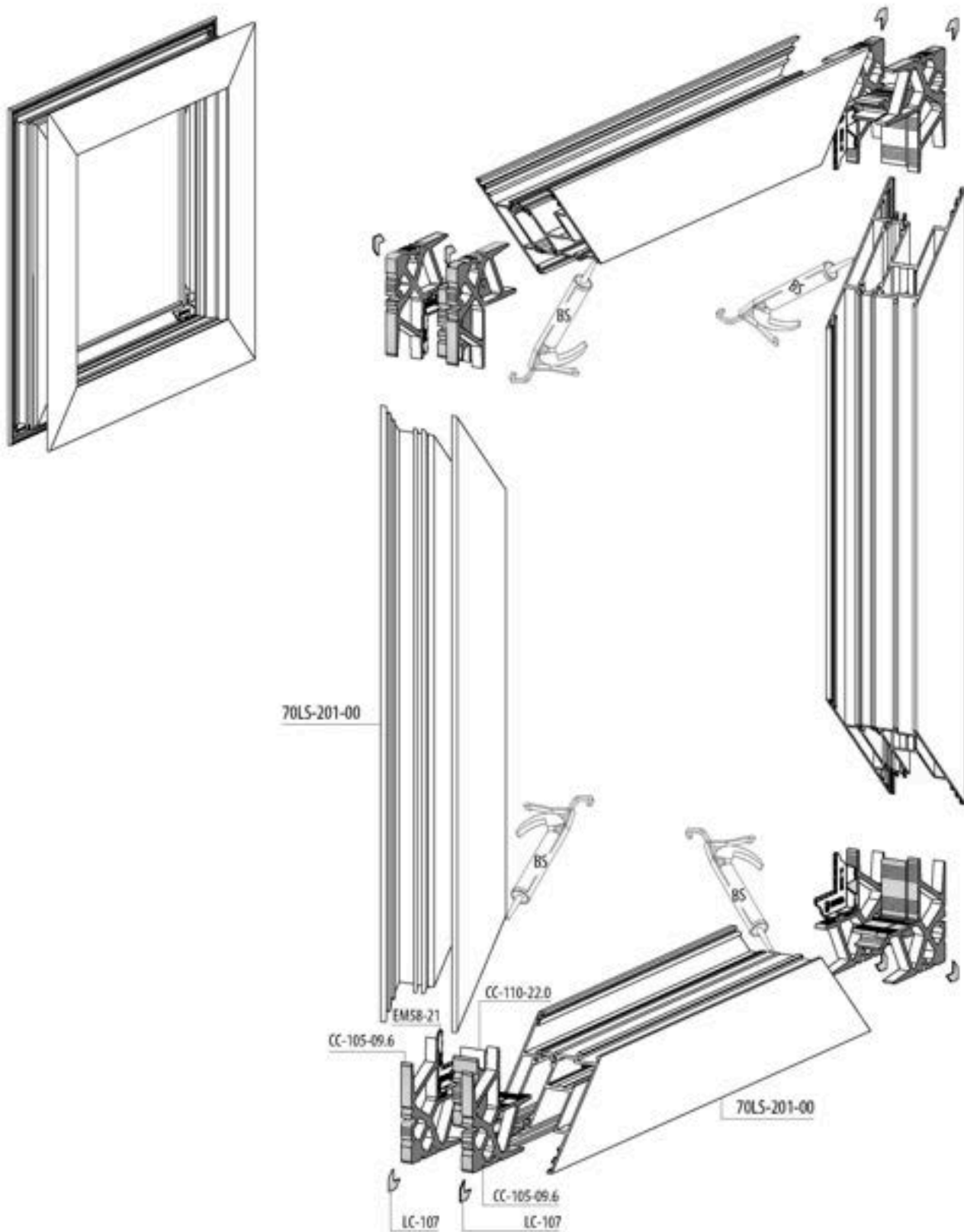

 S = SILICONE SILIKON
 ES = EPDM BOND / EPDM YAPISIZICI
 BS = BOND AND SEAL / YAPISIZICI VE SIZDIRMAZ

SASH DRAINAGE HOLES / KANAT TAHLİYE DELİKLERİ

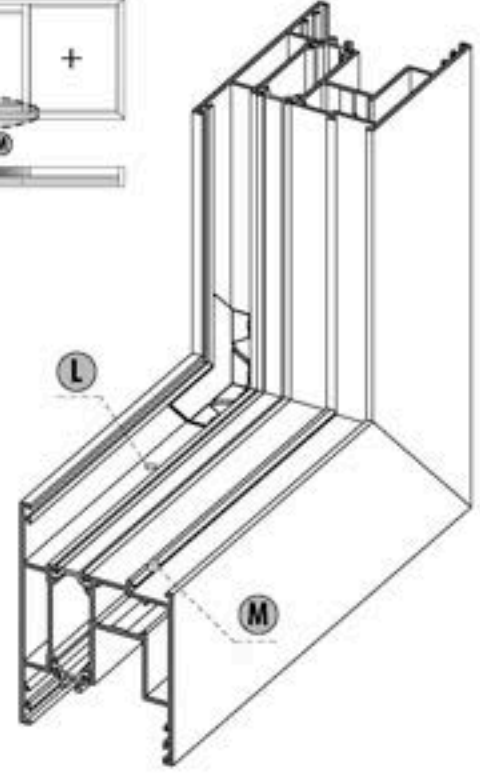
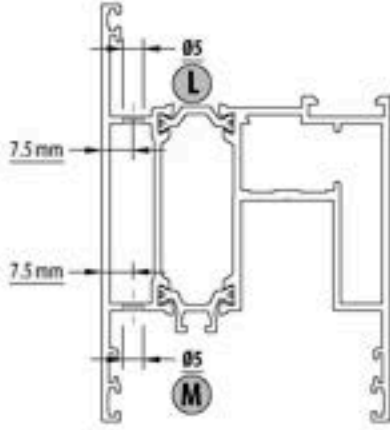
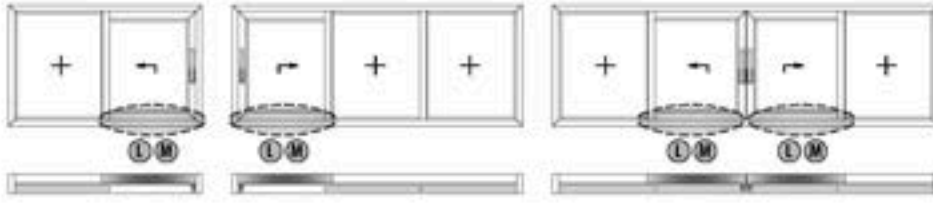

OPERATIONS / İŞLEMLER

- L** (70LS-201-00) Sash / Kanat
* Ø5 mm Hole / Delik
- M** (70LS-201-00) Sash / Kanat
* Ø5 mm Hole / Delik

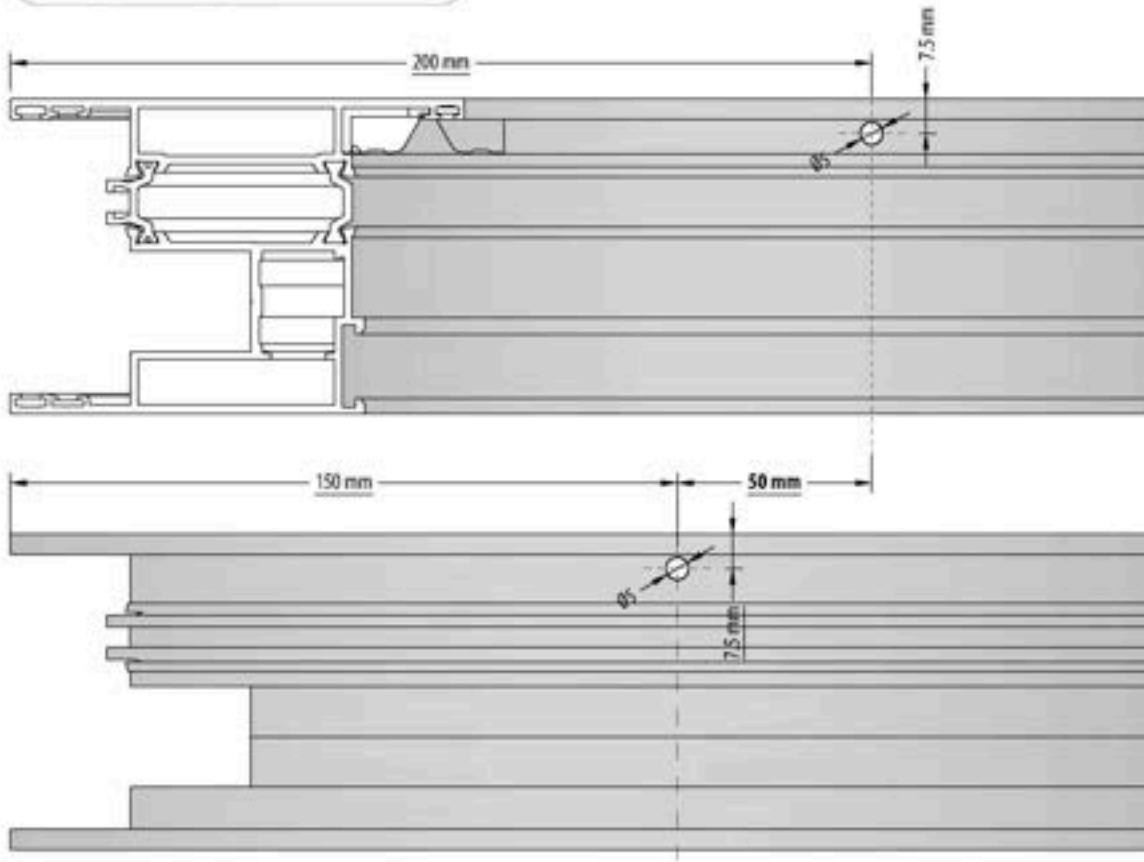

SASH AERATION HOLES / KANAT HAVALANDIRMA DELİKLERİ

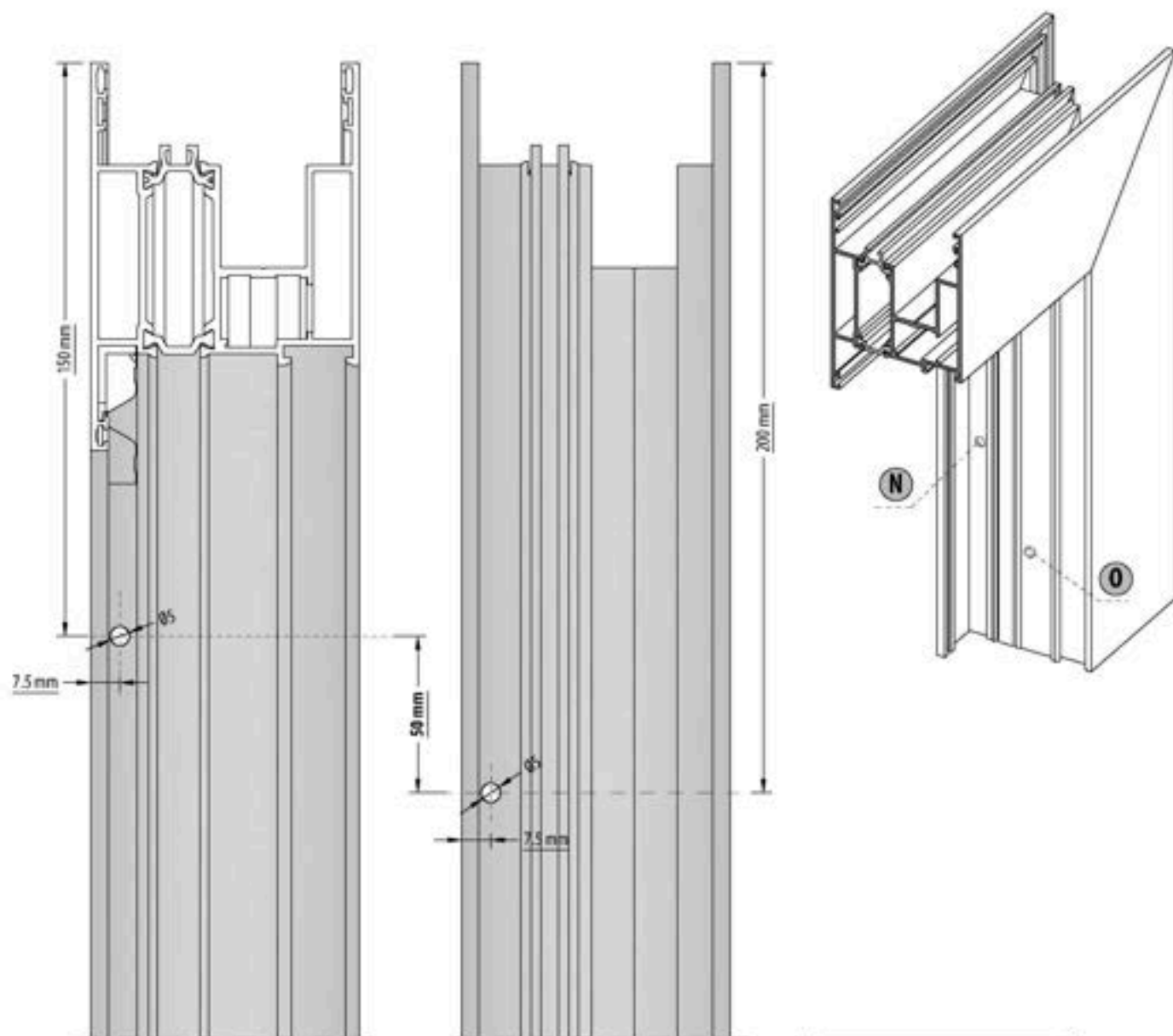

OPERATIONS / İŞLEMLER

- N** (70LS-201-00) Sash / Kanat
* Ø5 mm Hole / Delik
- O** (70LS-201-00) Sash / Kanat
* Ø5 mm Hole / Delik

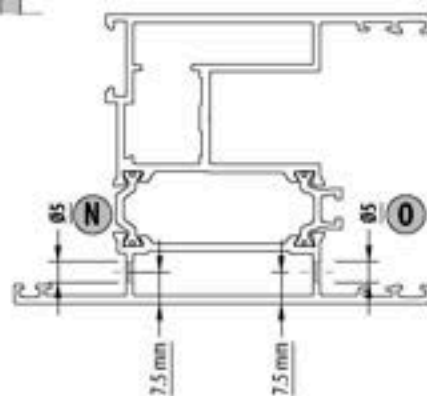

WEATHER STRIP MONTAGE / HAVA KESİCİ MONTAJI

EM70LS-32
WEATHER STRIP SET
2000x1000
KESİTİMİ

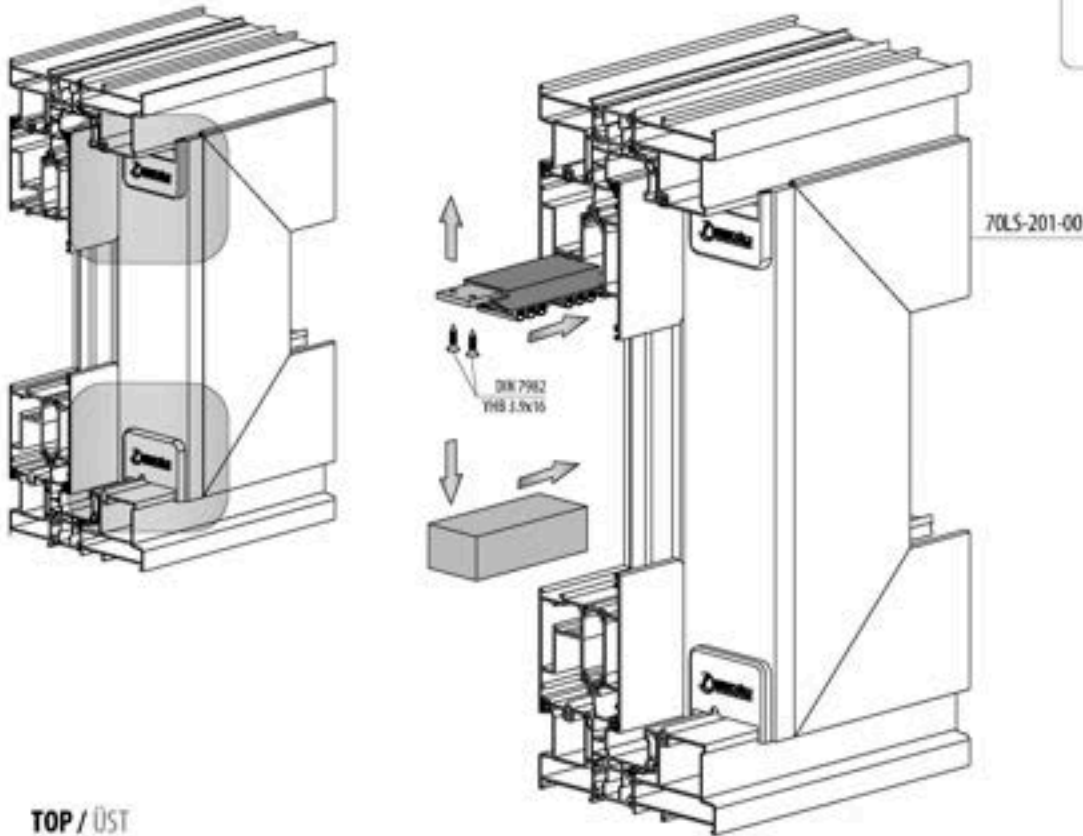

TOP / ÜST

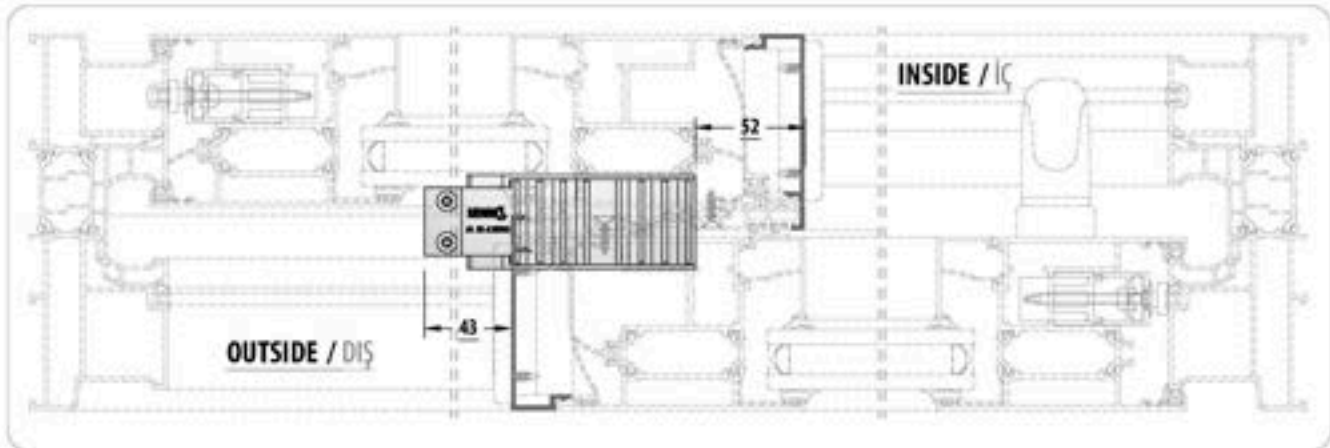

BOTTOM / ALT

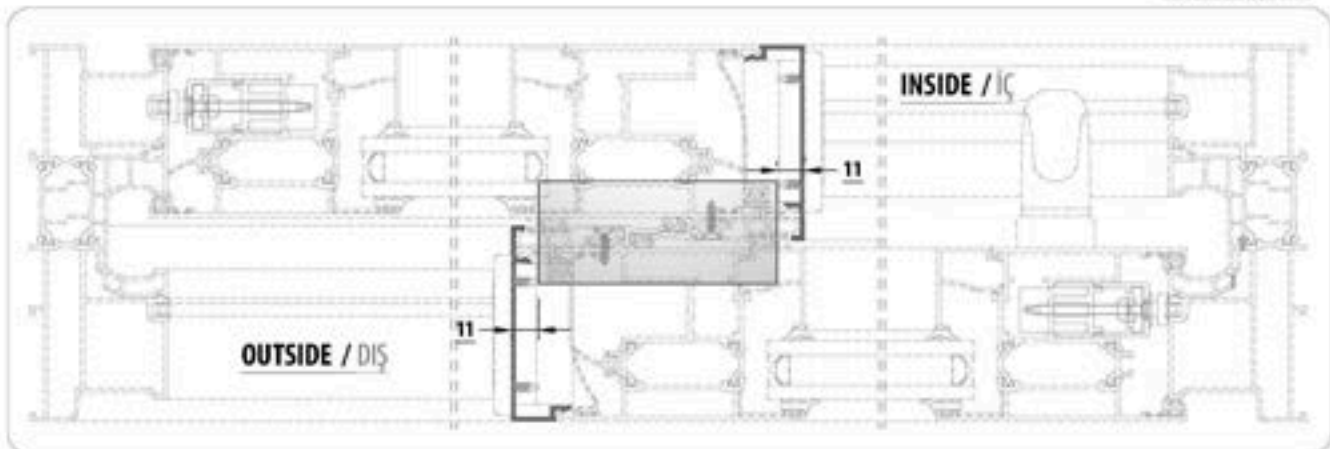

MONTAGE DIMENSION / MONTAJ ÖLÇÜLERİ



A

NOCH / KERTME

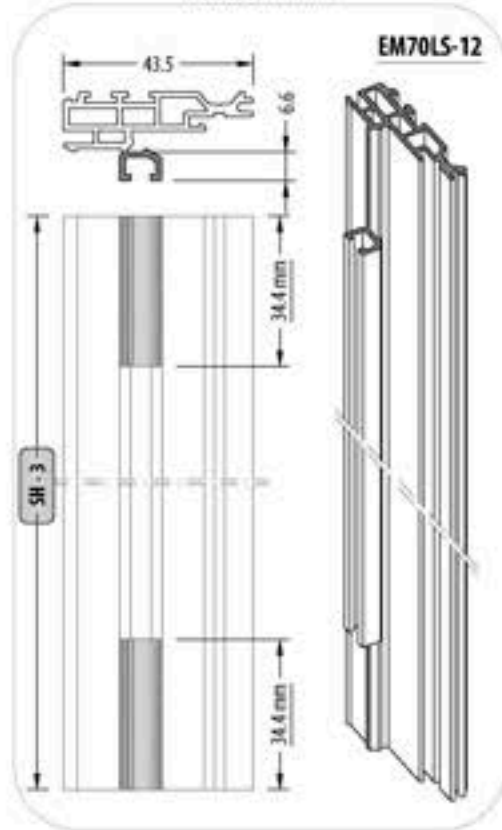

OPERATIONS / İŞLEMLER

- A** EM70LS-12
Pvc Adapter Noch / Pvc Adaptör Kertme
- EM70LS-02, 70LS-502-00, EM70LS-12
B Profile Montage / Profil Montajı
70LS-502-00, EM70LS-12
Holes / Delik Delme
- EM70LS-06
C Brush Montage / Ferça Montajı
- 70LS-501-00 Cap Profile Noch / Kapak Profil Kertme
- EM70LS-01 Gasket Montage / Fıtlı Montajı
EM70LS-04 Gasket Montage / Fıtlı Montajı
70LS-501-00 Cap Profile Montage / Kapak Profil Montajı

SASH CLAMP PROFILE ASSEMBLY / KANAT KENET PROFİL MONTAJI

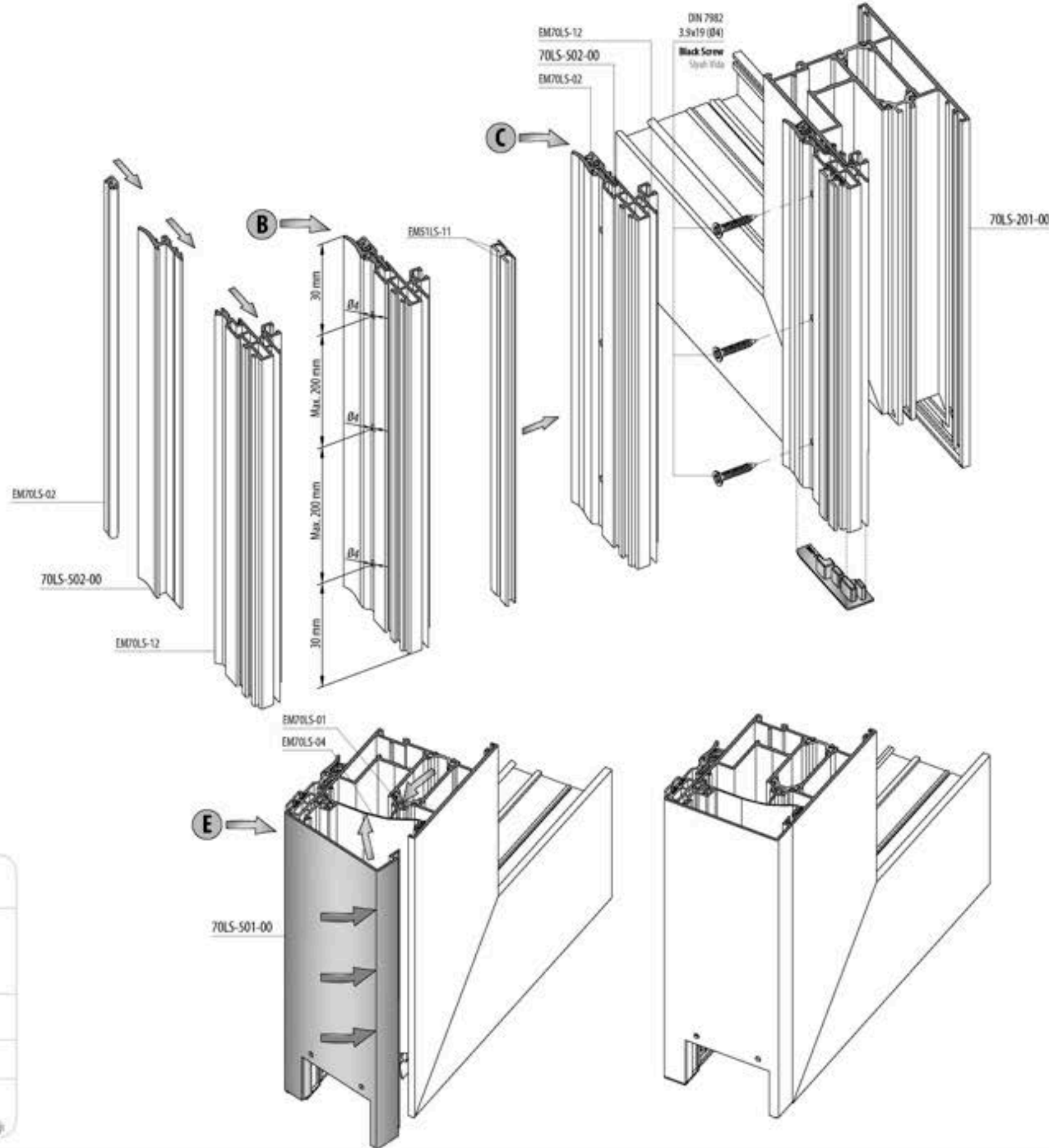

B

HOLES / DELİK DELME

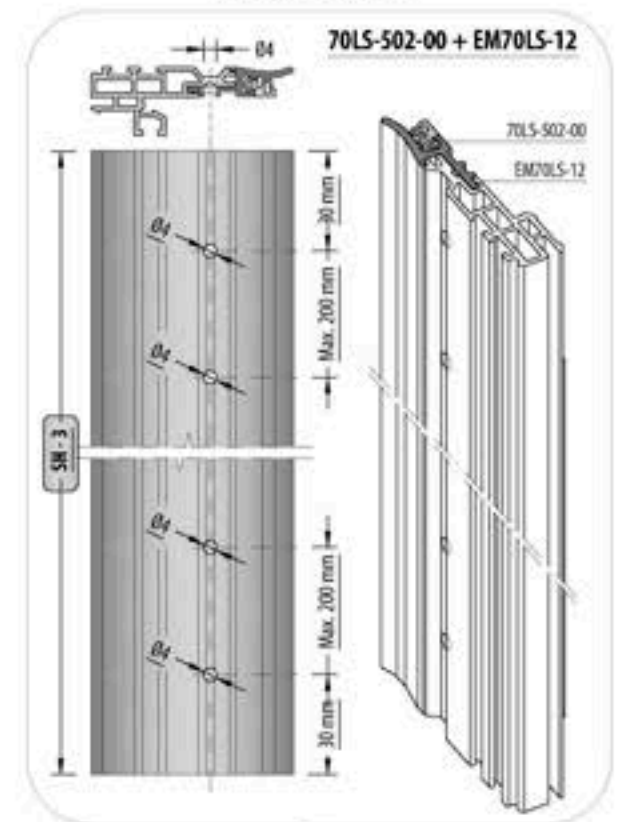

D

NOCH / KERTME

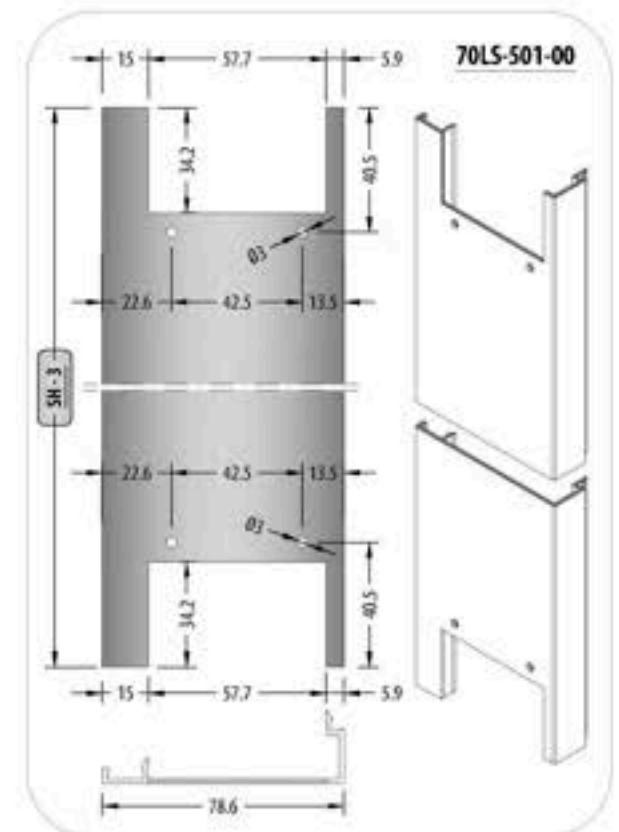

CLAMPING CAP ASSEMBLY / KENET KAPAK MONTAJI

EM70LS-201
CLAMPING
ACCESSORIES SET
KENET AKSESUAR TAKIMI

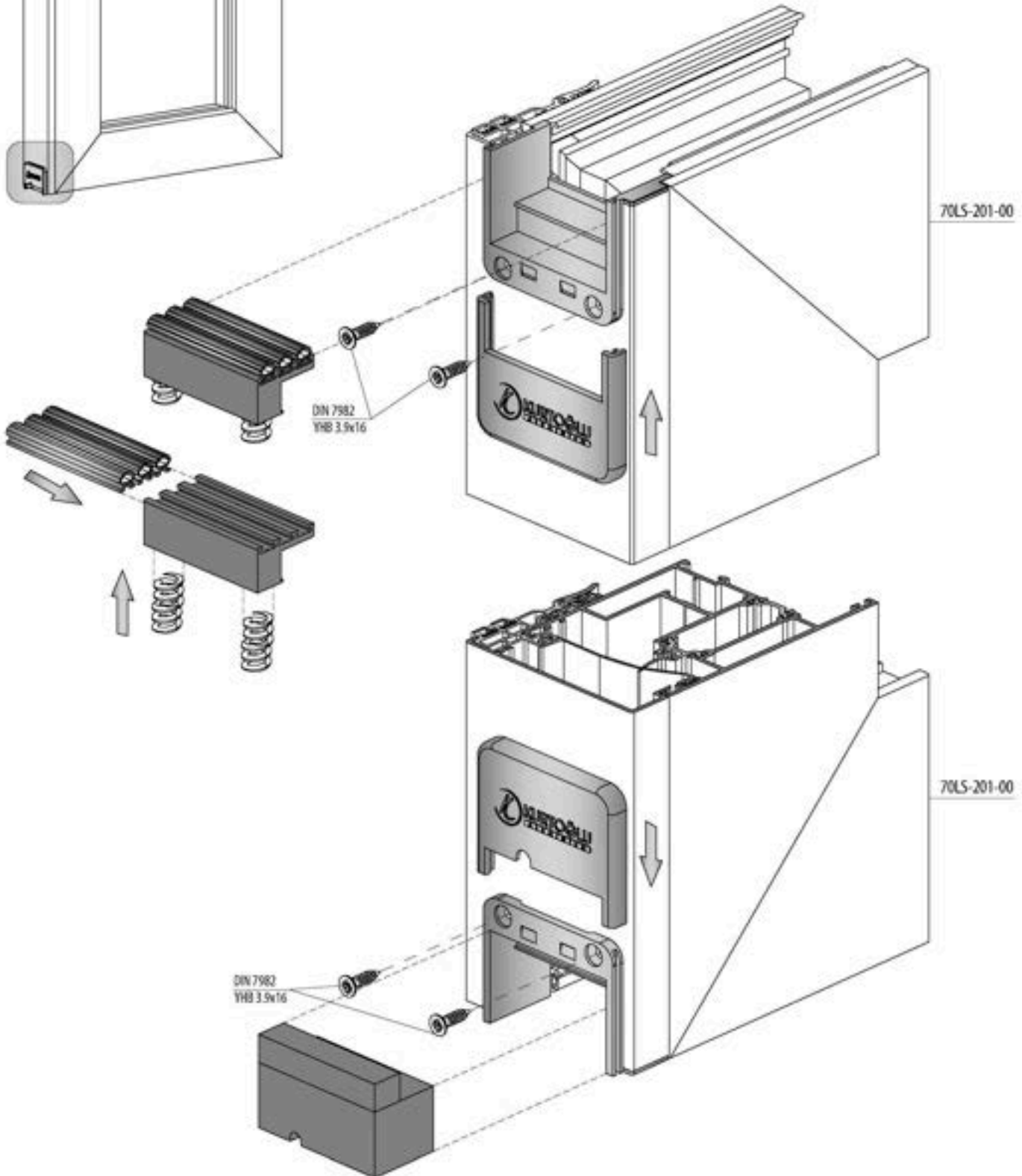
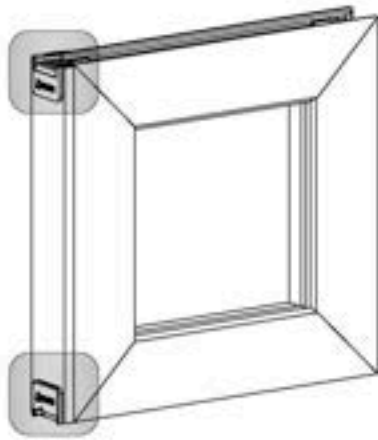

FRAME ASSEMBLY SCREW APPLICATION
KASA MONTAJ VİDA UYGULAMASI

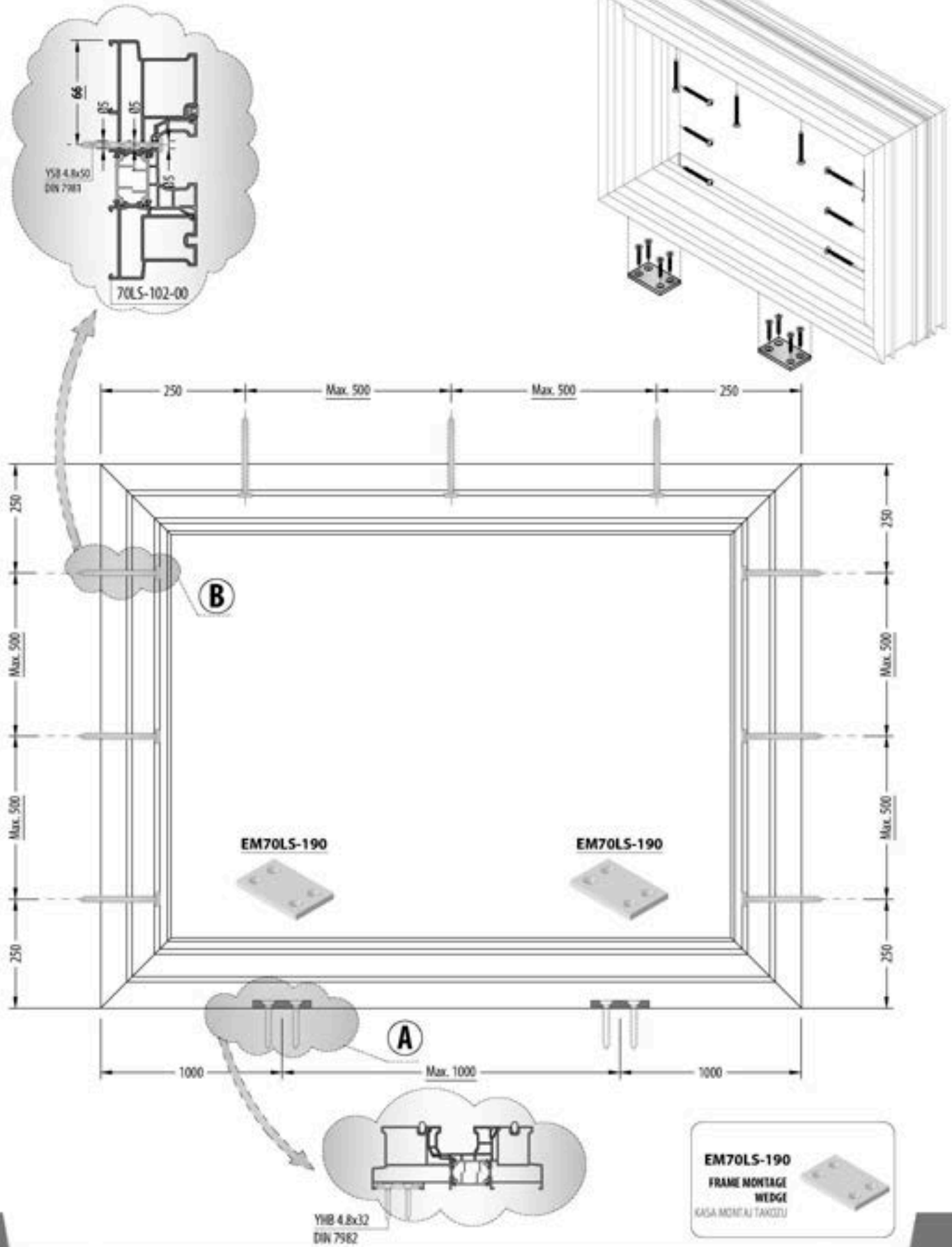

FRAME ASSEMBLY / KASA UYGULAMA

WITH PRES CORNER JOINT
KÖŞE TAKOZU İLE

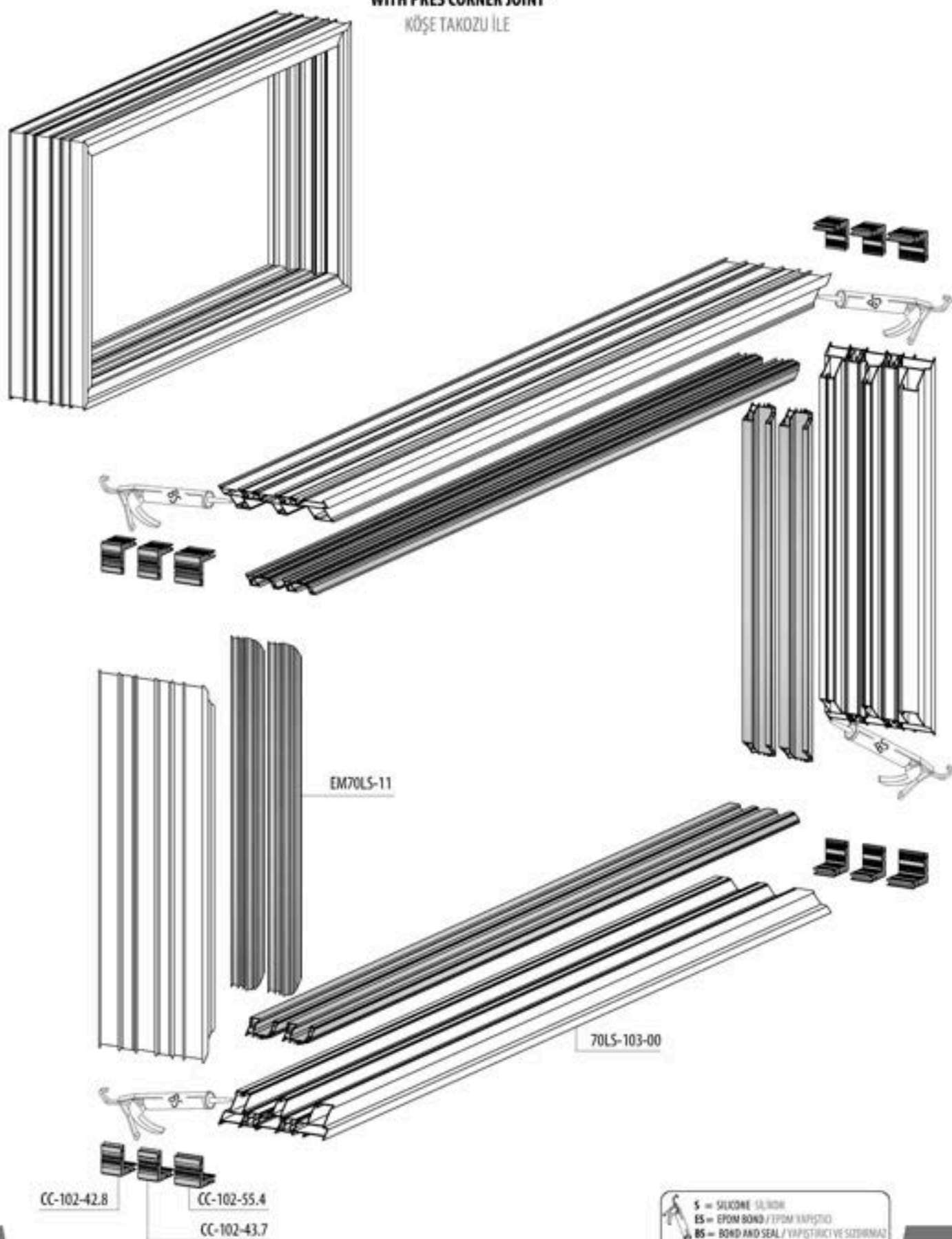

ACTIVE SIDE DRAINAGE / AKTİF YANLIL DRENAJ

70LS-103-00

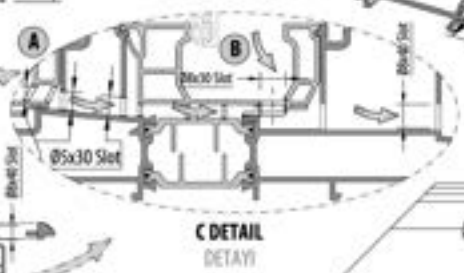
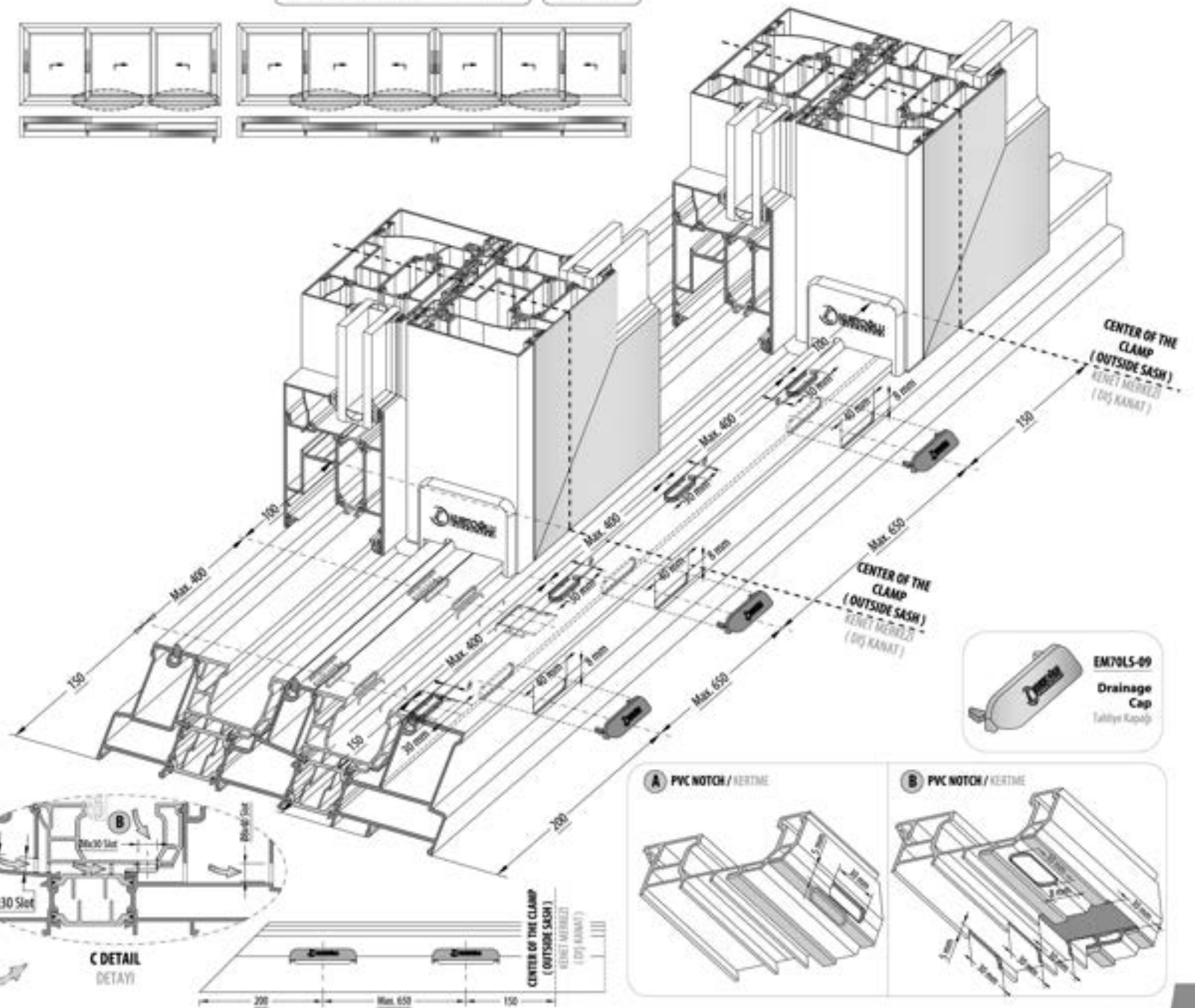
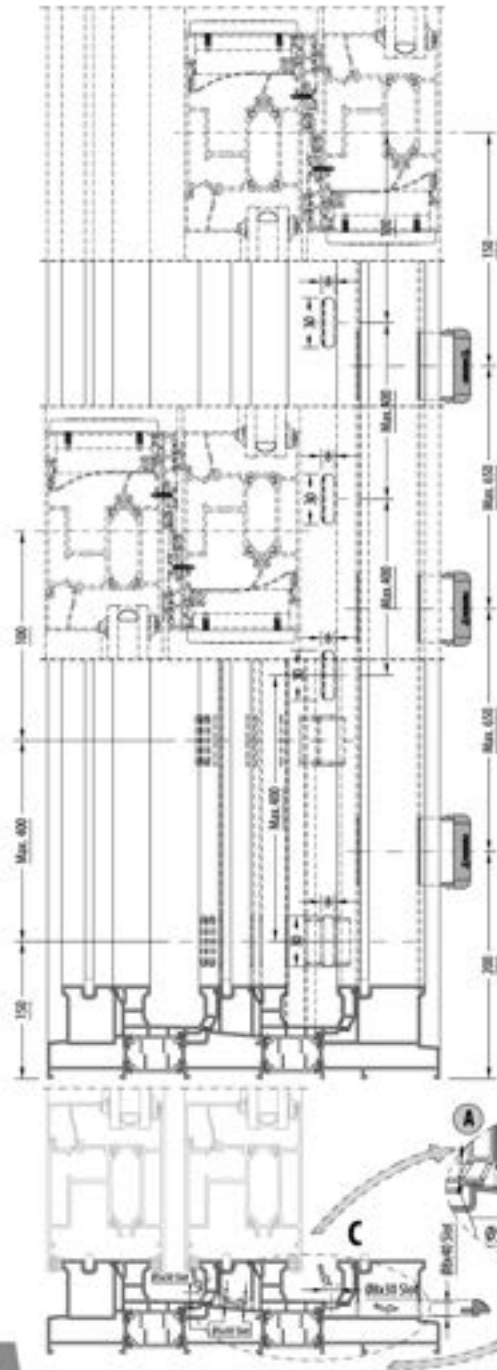
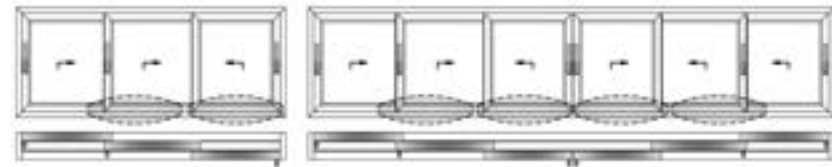

SASH ASSEMBLY / KANAT UYGULAMA

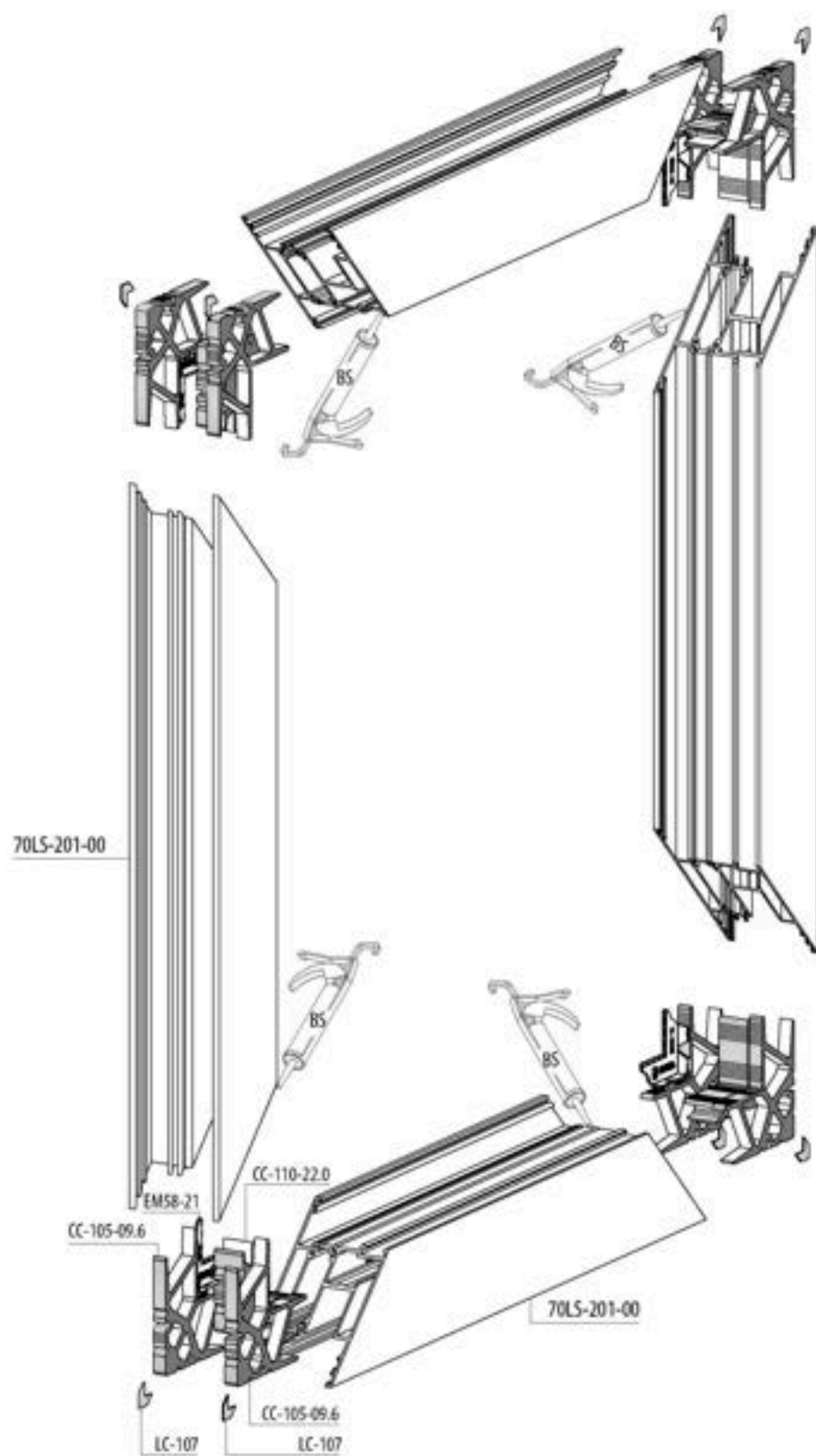

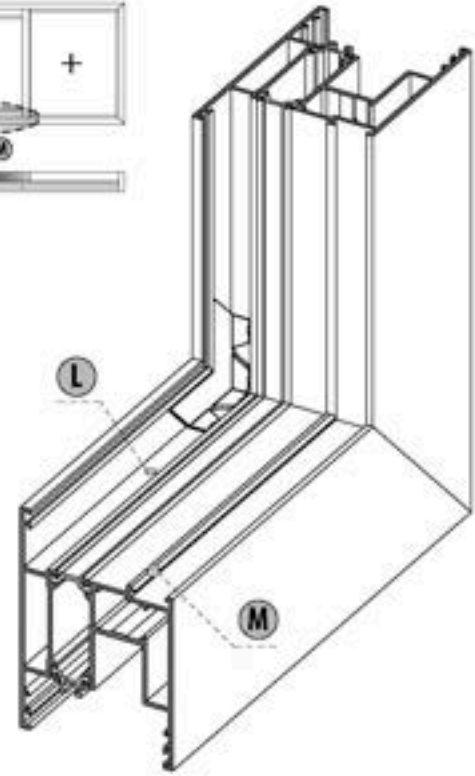
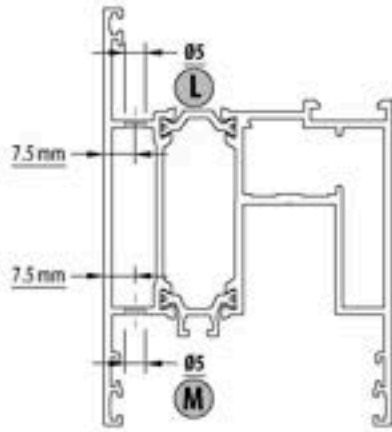
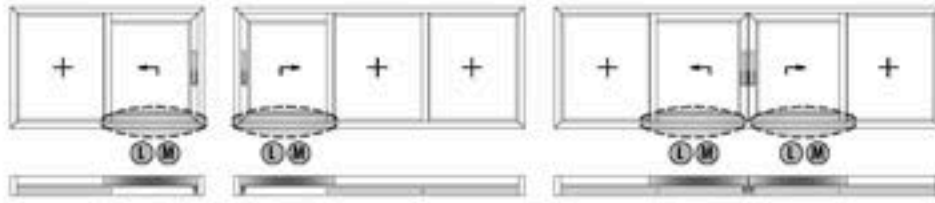

S = SILICONE SİLİKON
ES = EPDM BOND / EPDM YAPISIZICI
BS = BOND AND SEAL / YAPISIZICI VE SIZDIRMAZ

SASH DRAINAGE HOLES / KANAT TAHLİYE DELİKLERİ

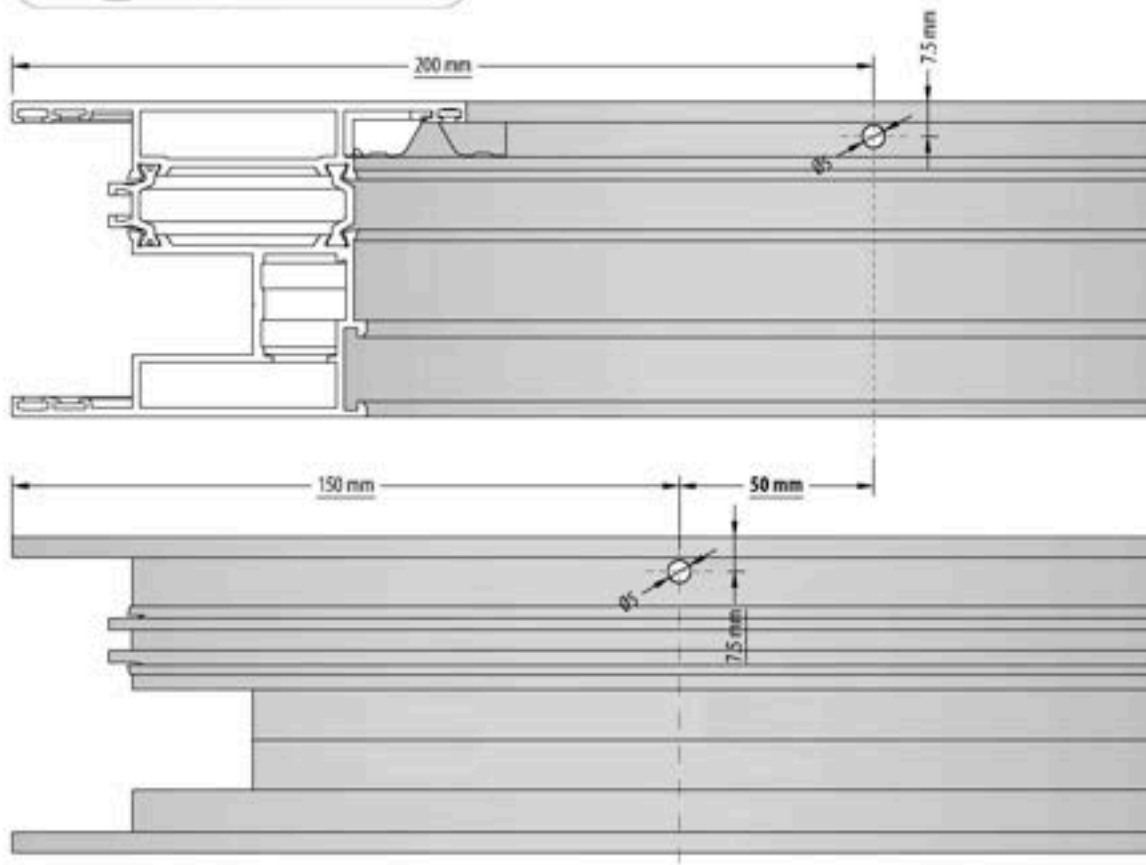

OPERATIONS / İŞLEMLER

- L** (70LS-201-00) Sash / Kanat
* Ø5 mm Hole / Delik
- M** (70LS-201-00) Sash / Kanat
* Ø5 mm Hole / Delik



SASH AERATION HOLES / KANAT HAVALANDIRMA DELİKLERİ

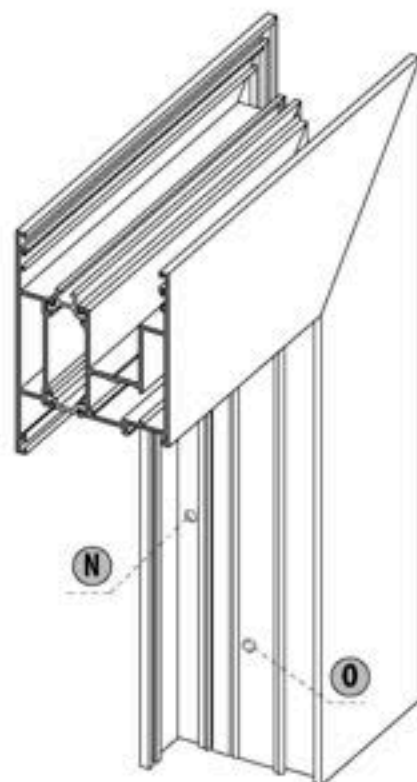
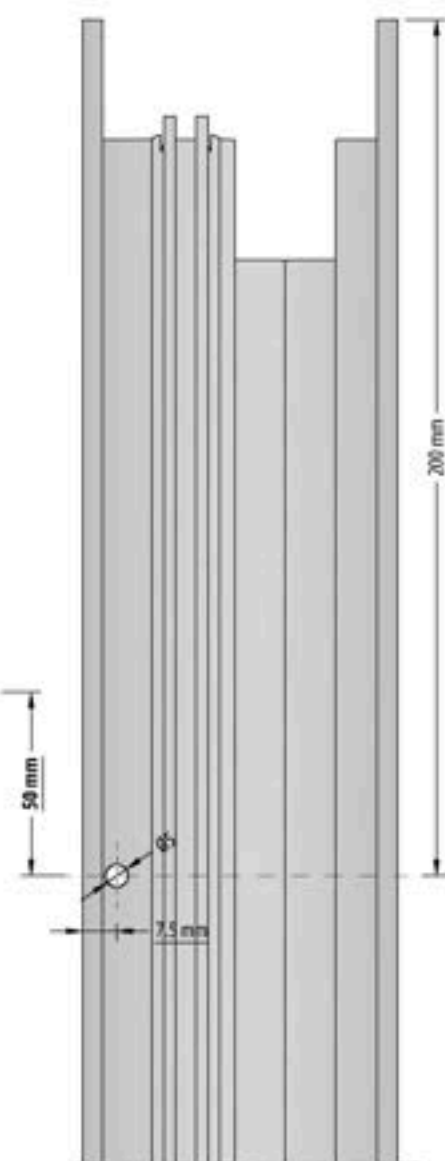
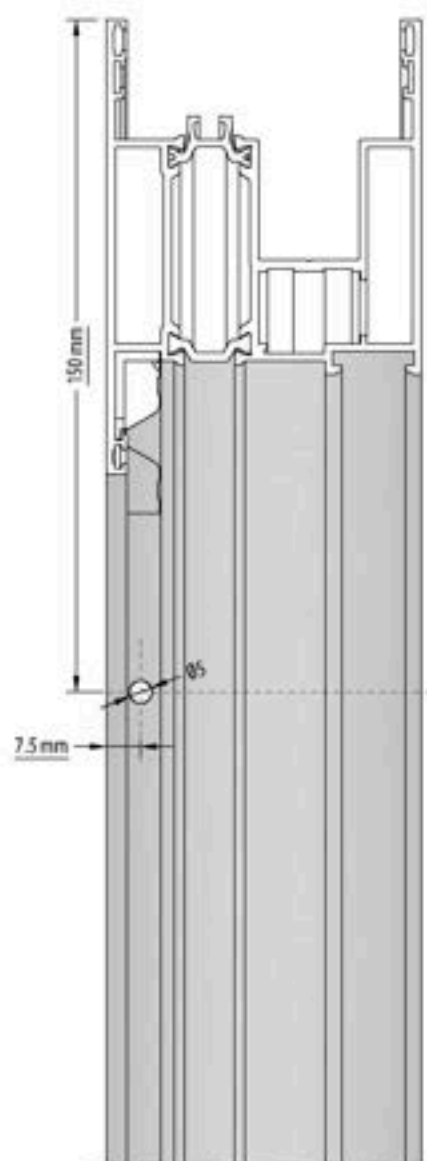

OPERATIONS / İŞLEMLER

N (70LS-201-00) Sash / Kanat
* Ø5 mm Hole / Delik

O (70LS-201-00) Sash / Kanat
* Ø5 mm Hole / Delik

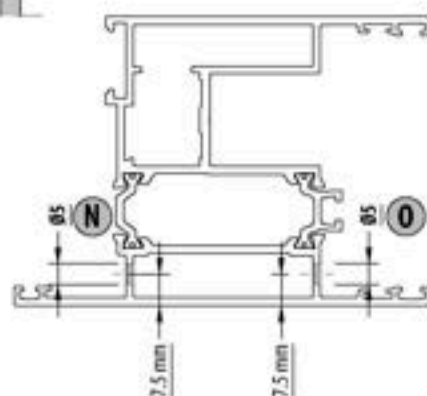

WEATHER STRIP MONTAGE / HAVA KESİCİ MONTAJI

EM70LS-32
WEATHER STRIP SET
PÜRÜZSÜZ
KEÇİLİNDİR

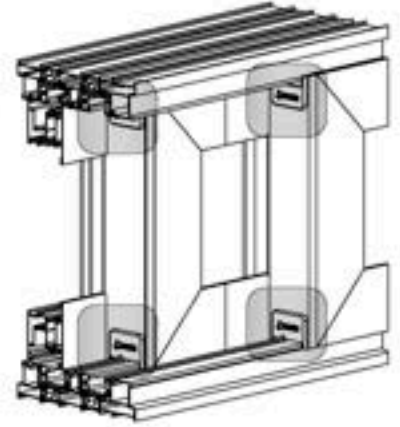
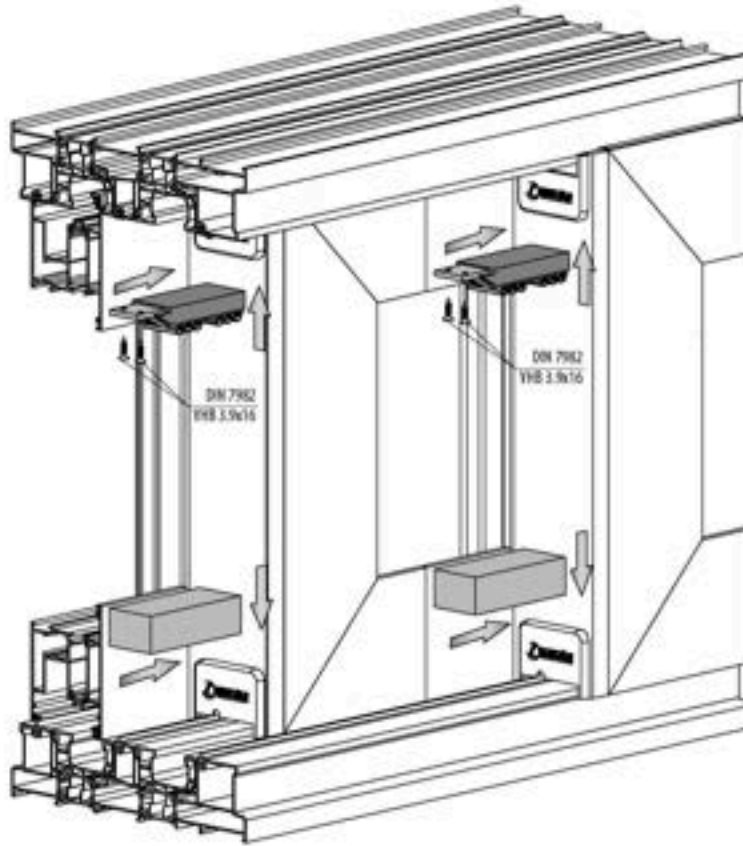

TOP / ÜST

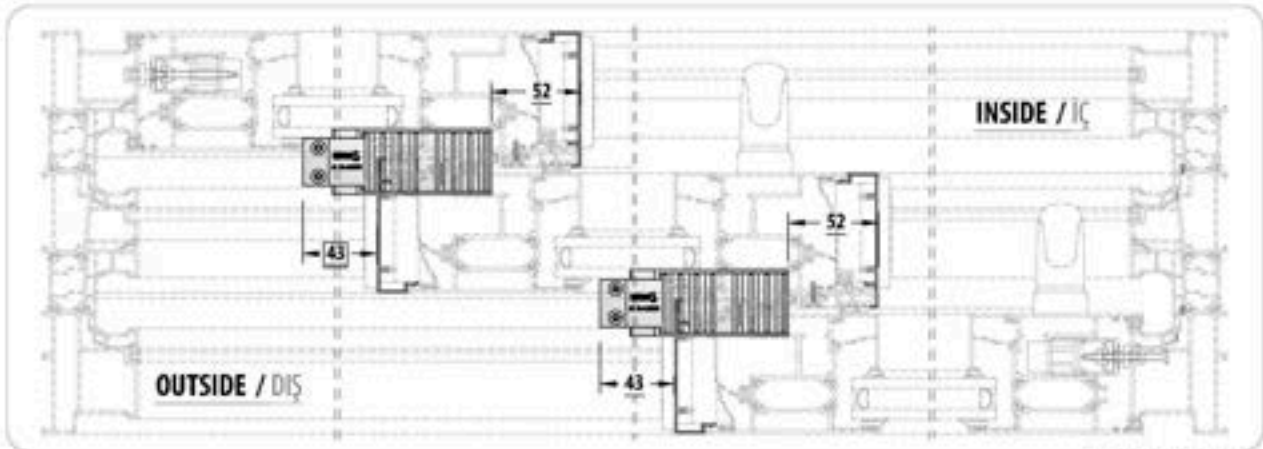

BOTTOM / ALT

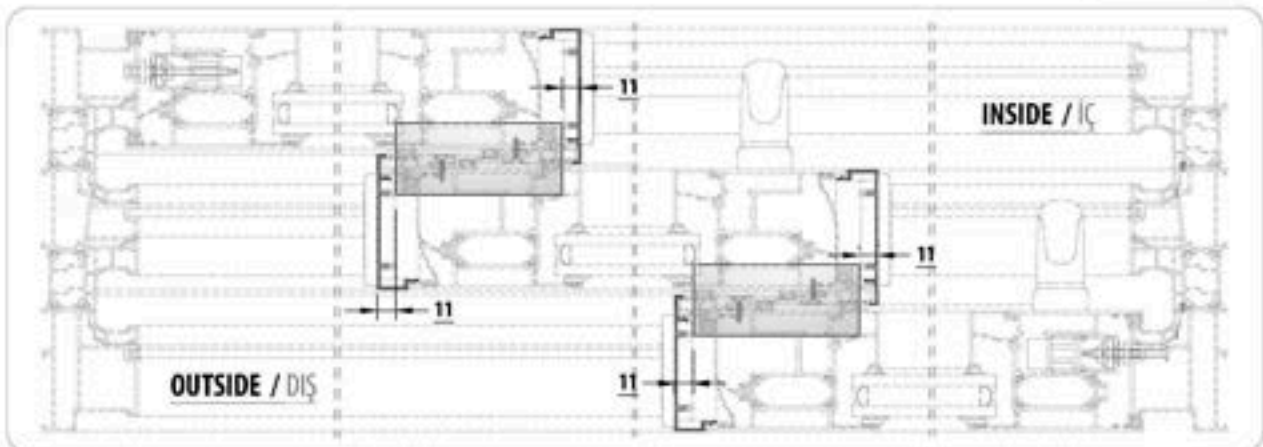

MONTAGE DIMENSION / MONTAJ ÖLÇÜLERİ



A

NOCH / KERTME

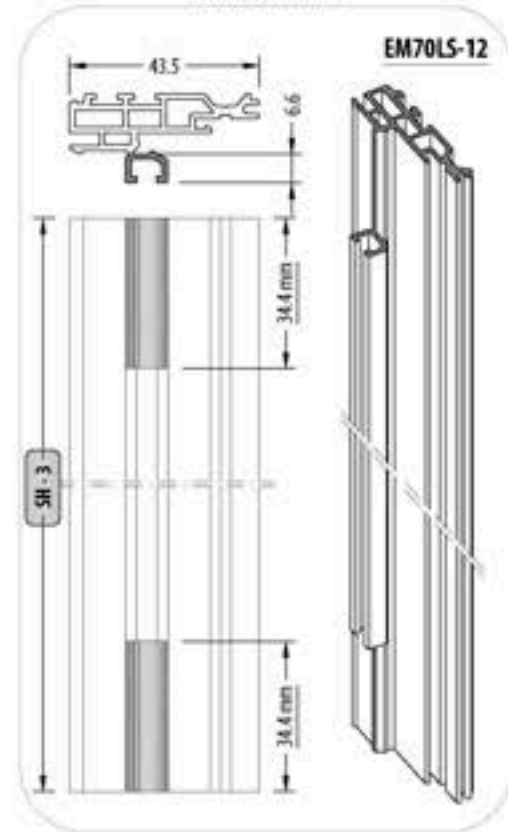

OPERATIONS / İŞLEMLER

- A** EM70LS-12
Pvc Adapter Noch / Pvc Adaptör Kertme
- EM70LS-02, 70LS-502-00, EM70LS-12
B Profile Montage / Profil Montajı
- 70LS-502-00, EM70LS-12
Holes / Delik Delme
- EM70LS-06
C Brush Montage / Ferça Montajı
- 70LS-501-00 Cap Profile Noch / Kapak Profil Kertme
- EM70LS-01 Gasket Montage / Fıtlı Montajı
- EM70LS-04 Gasket Montage / Fıtlı Montajı
- 70LS-501-00 Cap Profile Montage / Kapak Profil Montajı

SASH CLAMP PROFILE ASSEMBLY / KANAT KENET PROFİL MONTAJI

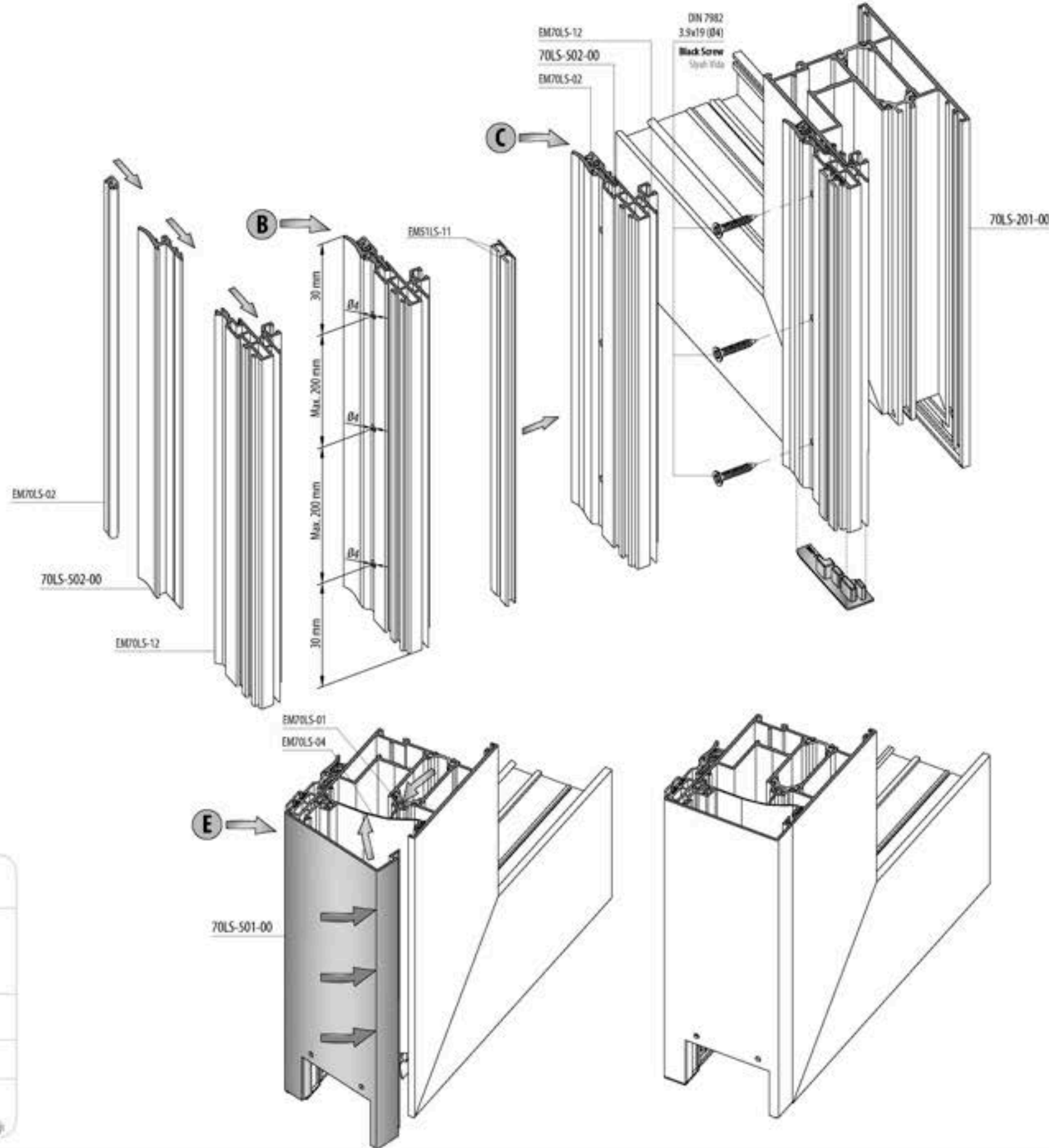

B

HOLES / DELİK DELME

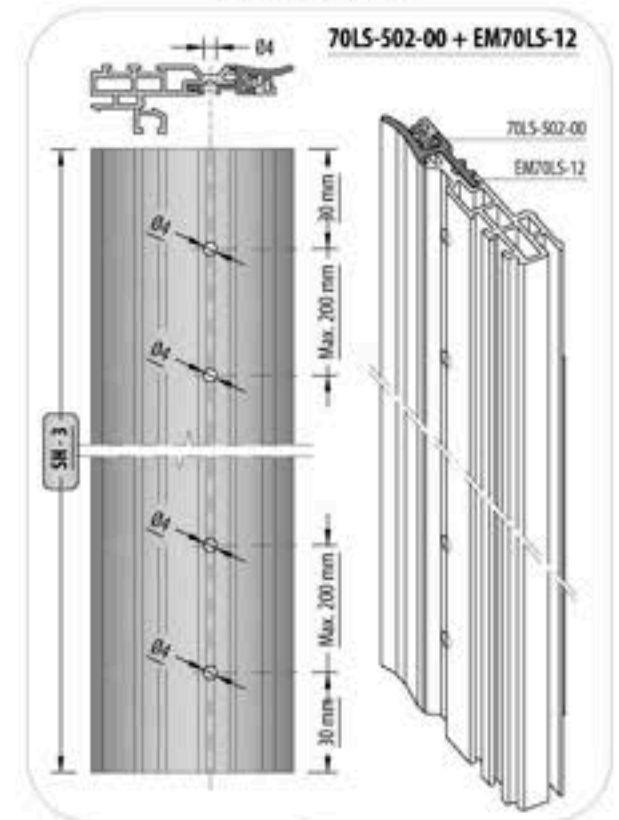

D

NOCH / KERTME

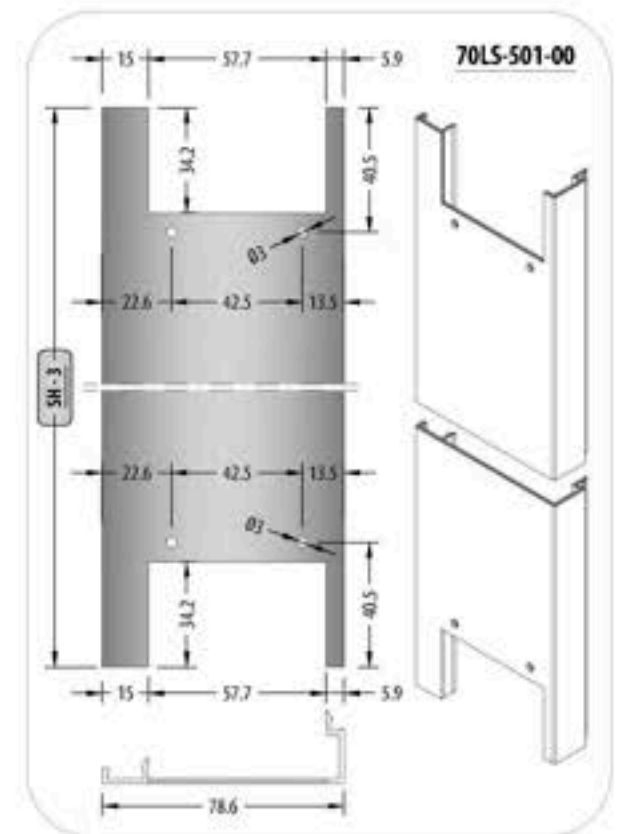

CLAMPING CAP ASSEMBLY / KENET KAPAK MONTAJI

EM70LS-201
CLAMPING
ACCESSORIES SET
KENET AKSESUAR TAKIMI

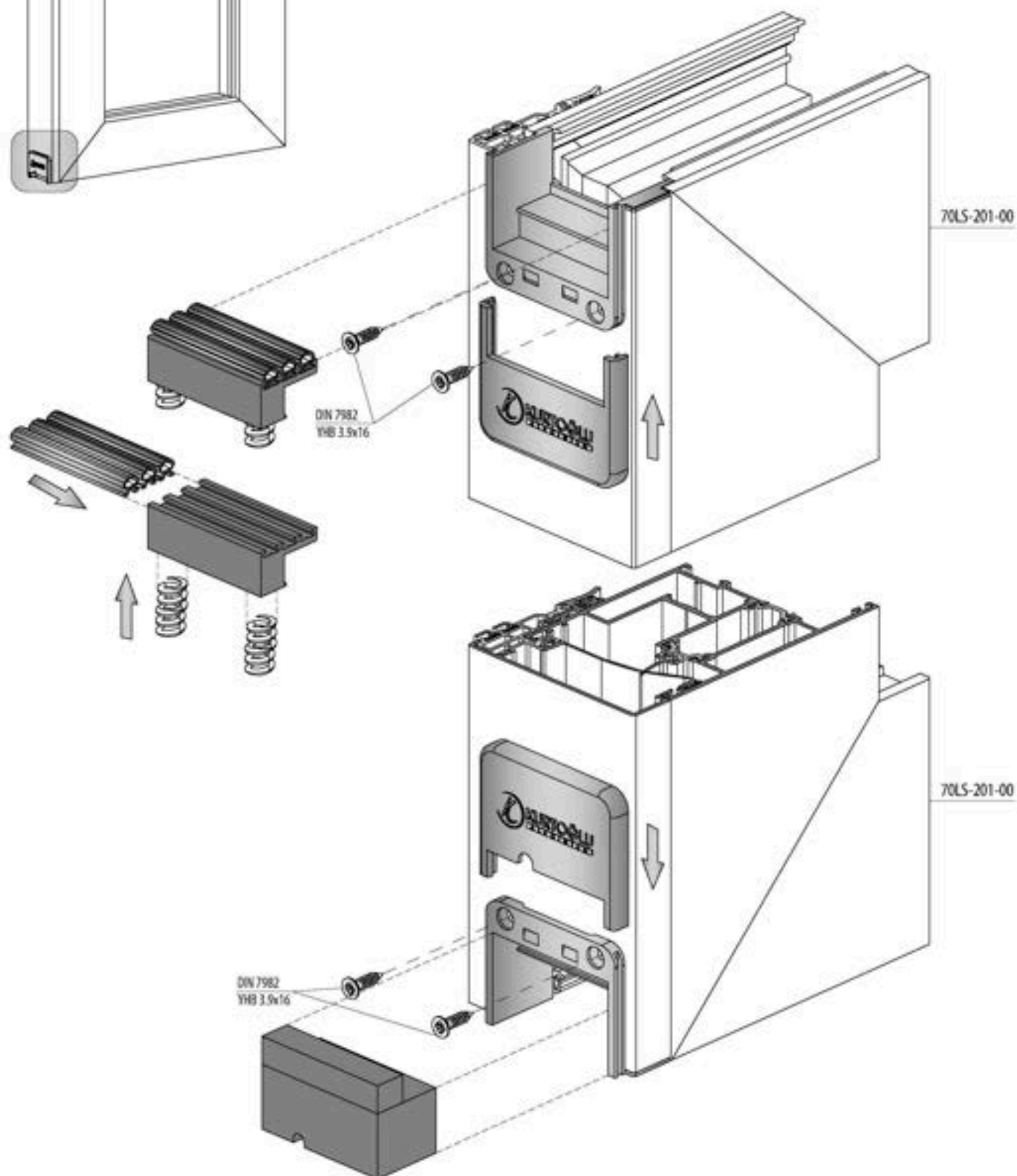
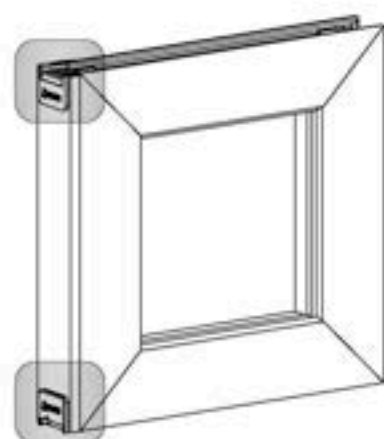

FRAME ASSEMBLY SCREW APPLICATION
KASA MONTAJ VIDA UYGULAMASI

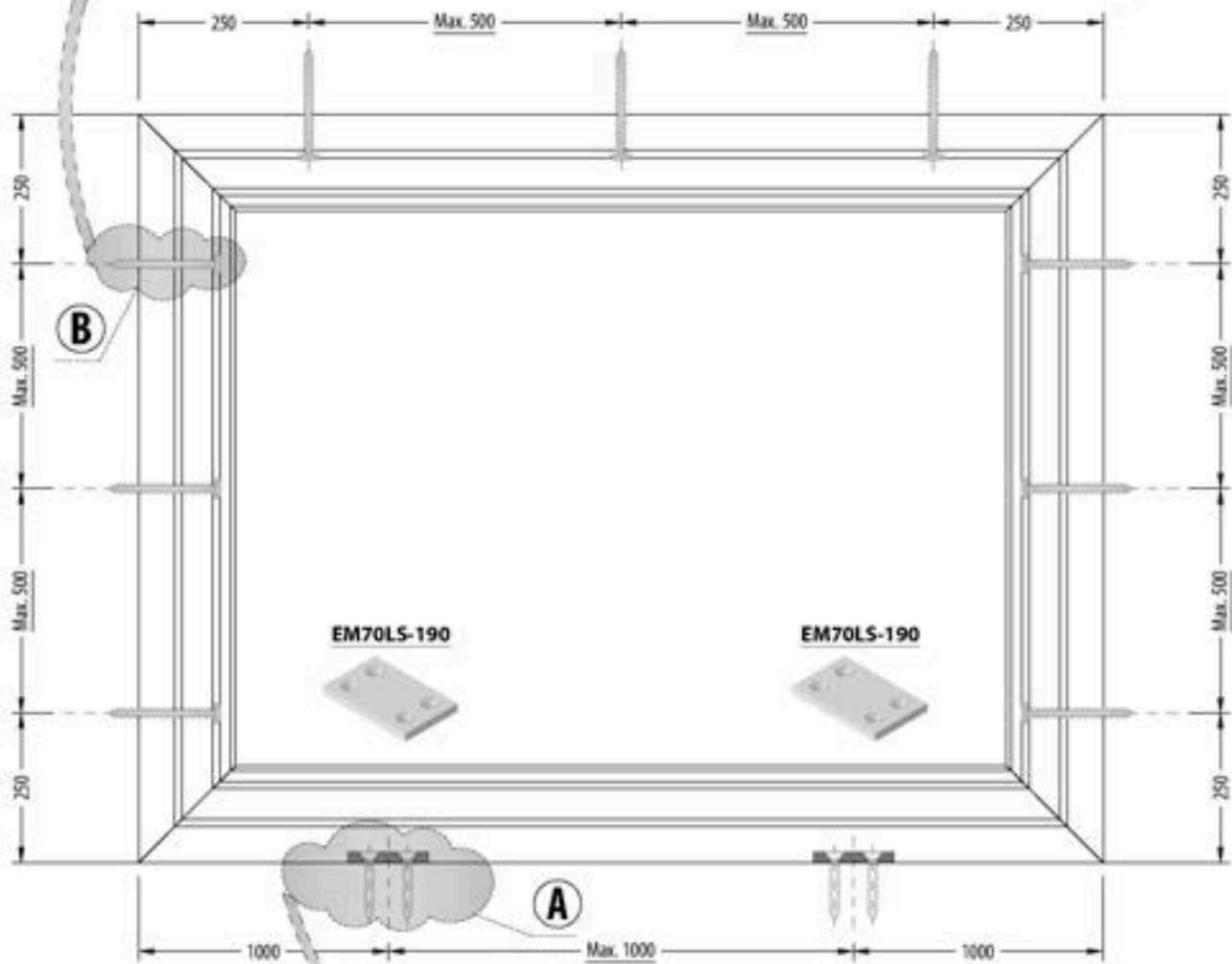
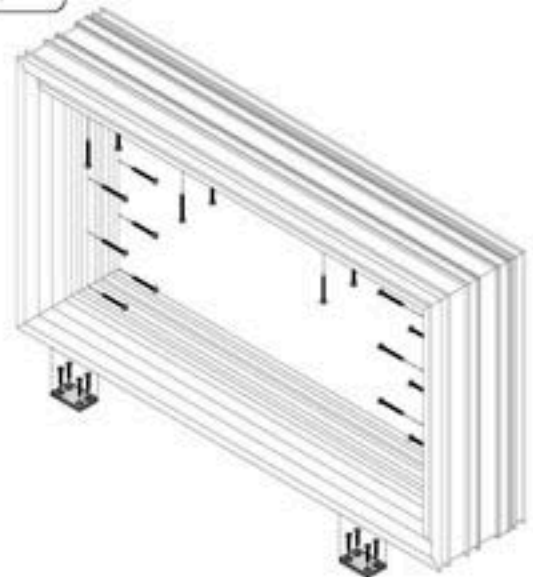
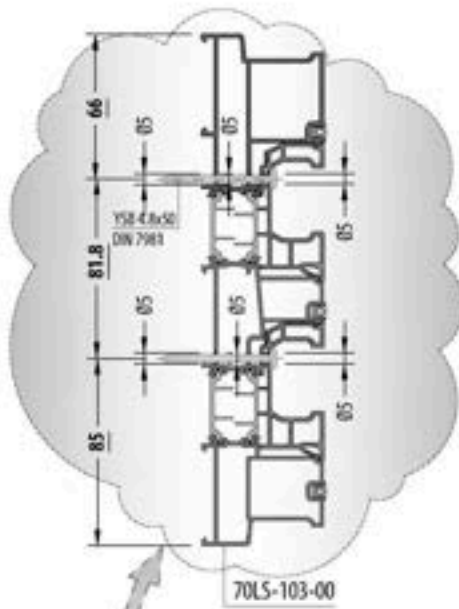

YHB 4.8x32
DIN 7982

EM70LS-190
FRAME MONTAGE
WEDGE
KASA MONTAJ TAKIYU



SASH FIXING WEDGE APPLICATION / KANAT SABİTLEME TAKOZ UYGULAMASI

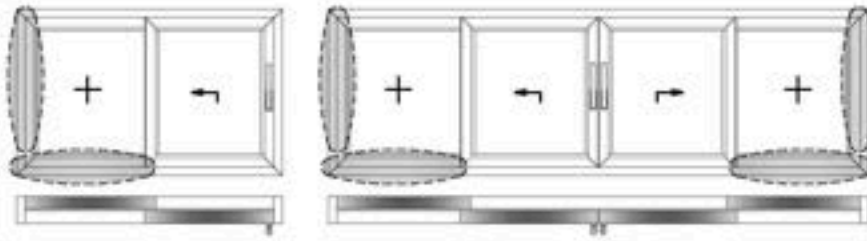

ACCESSORIES MONTAGE / AKSESUAR MONTAJI

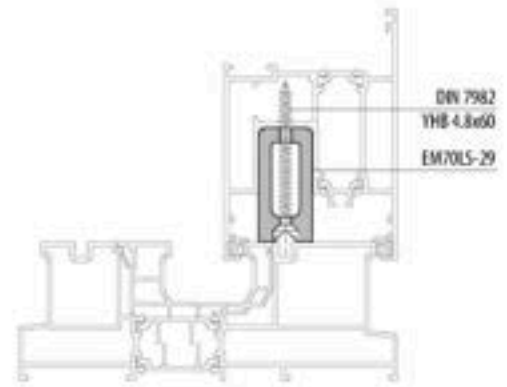
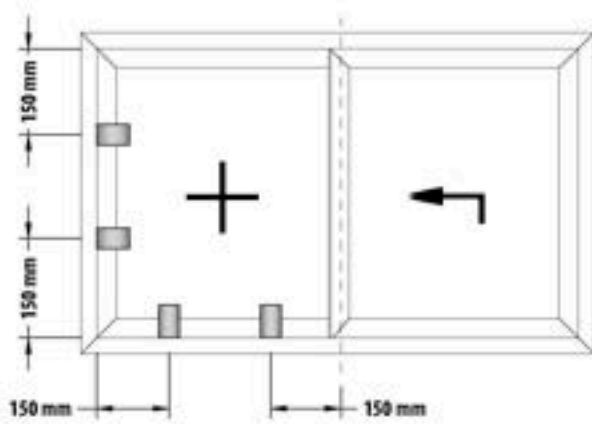

SASH MONTAGE / KANAT MONTAJI

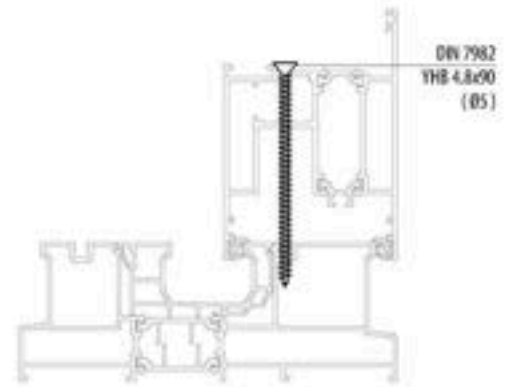
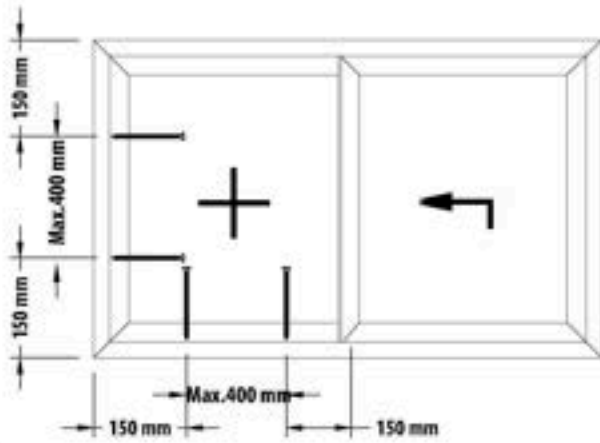

APPLICATION / UYGULAMA

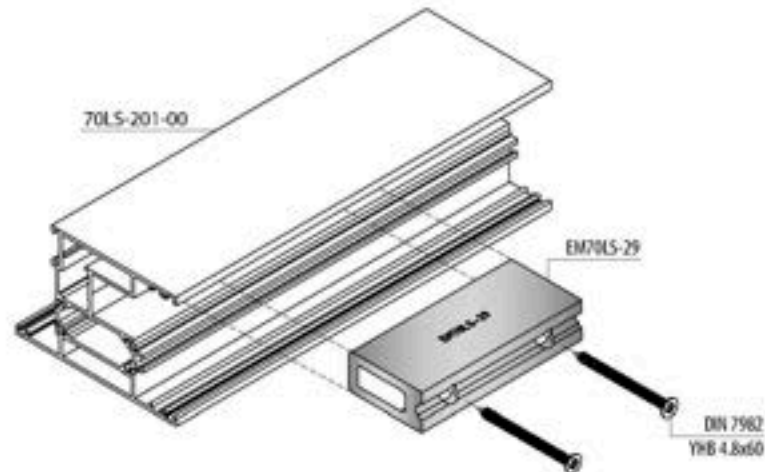

SASH STABILITY PLASTIC ASSEMBLY
KANAT DENGE PLASTİĞİ MONTAJI

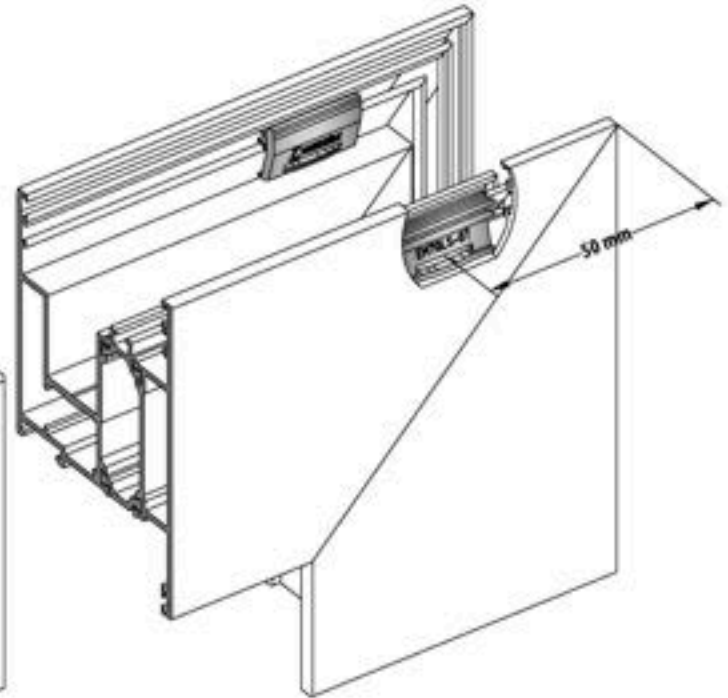
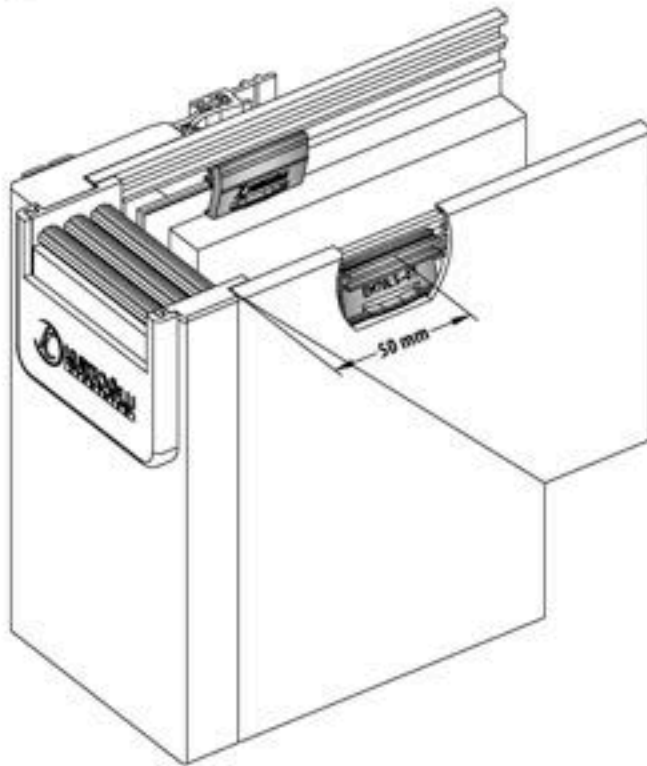

EM70LS-07
STABILITY ACCESSORY
DENGE AKSESUARİ



Sash / Kanat < 1500 mm if / ise 4 Pieces / Adet
Sash / Kanat > 1500 mm if / ise 6 Pieces / Adet

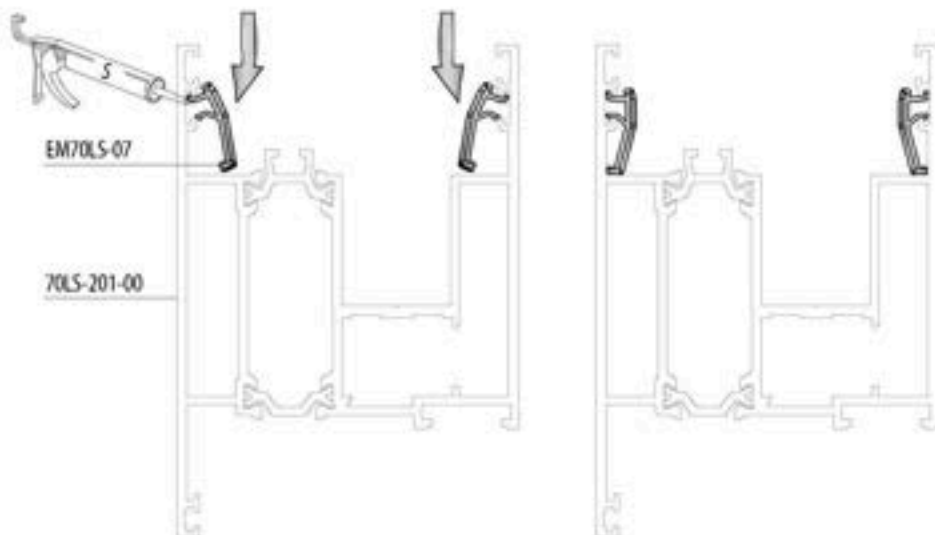

GASKET ASSEMBLY / FİTİL MONTAJI

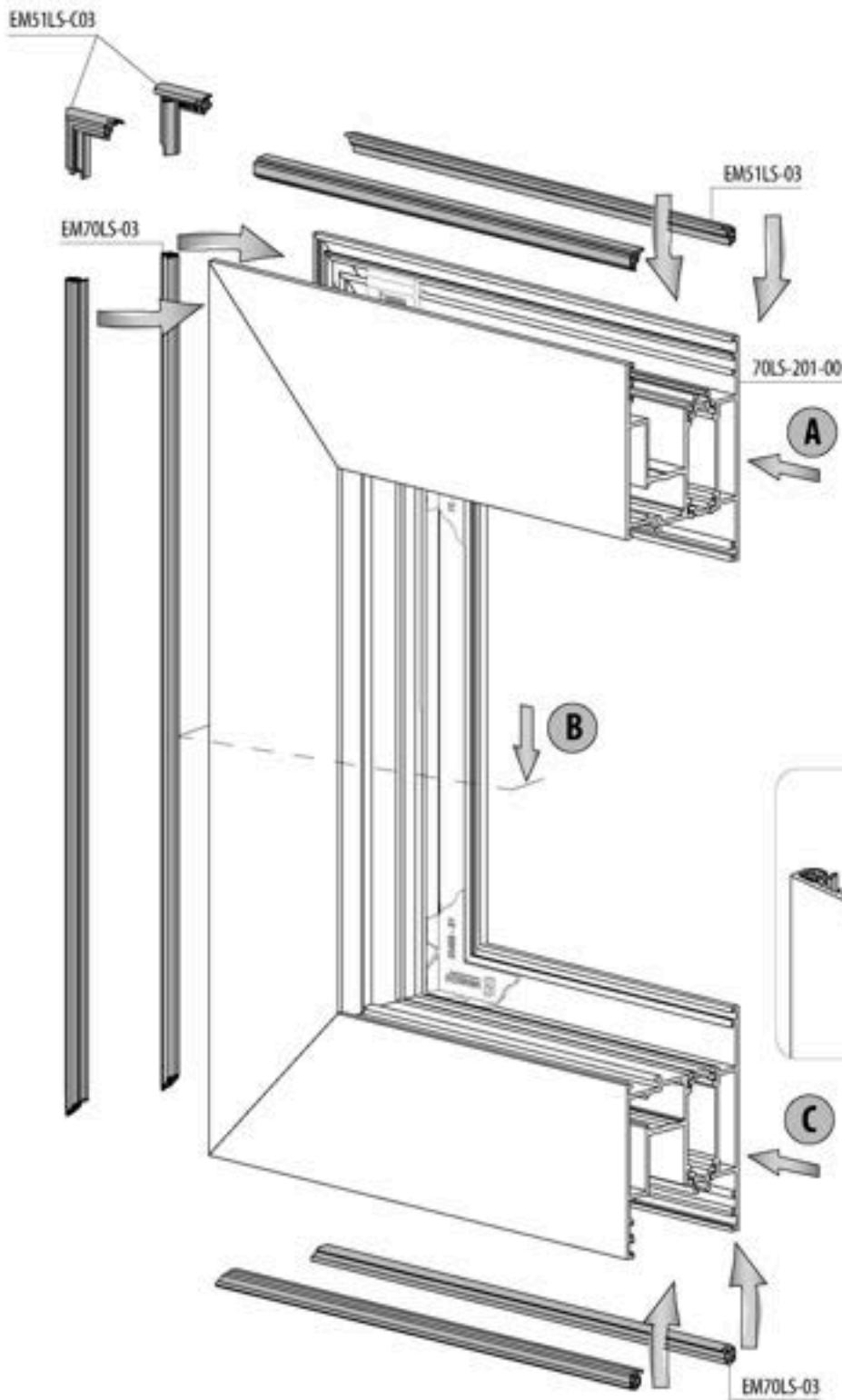

EM51LS-C03

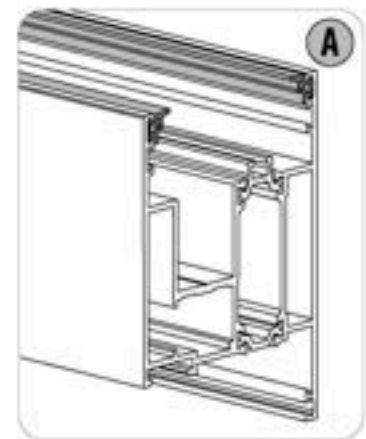
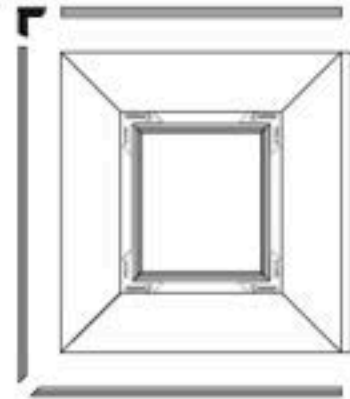

DROPPER CAP ASSEMBLY / DAMLALIK KAPAK MONTAJI

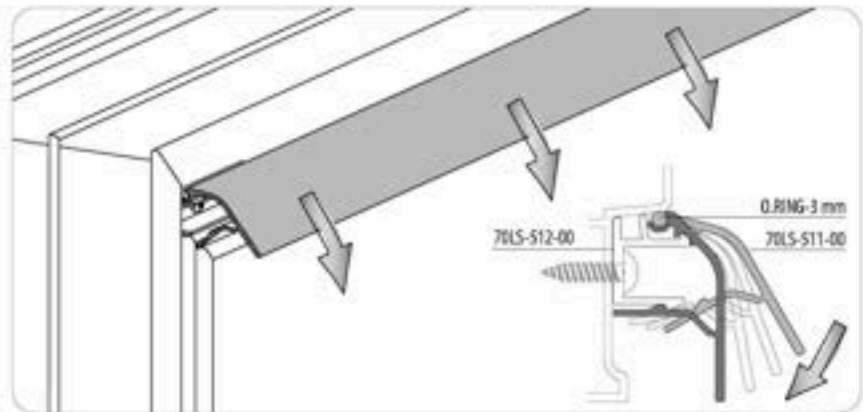
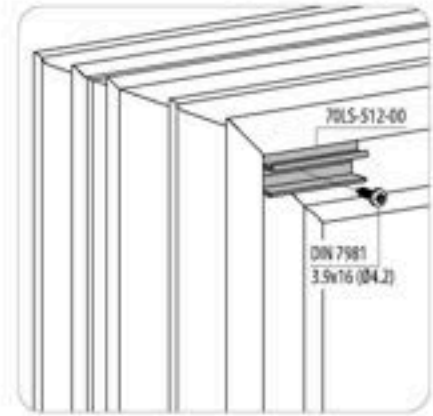
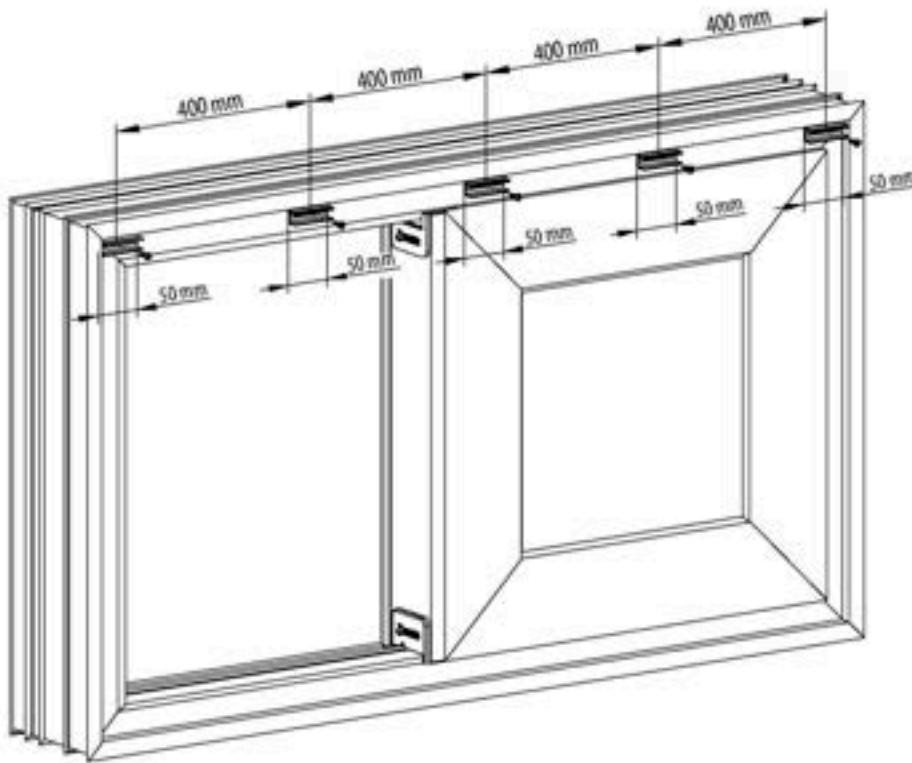

HOLES DIMENSION / DELİK ÖLÇÜLERİ

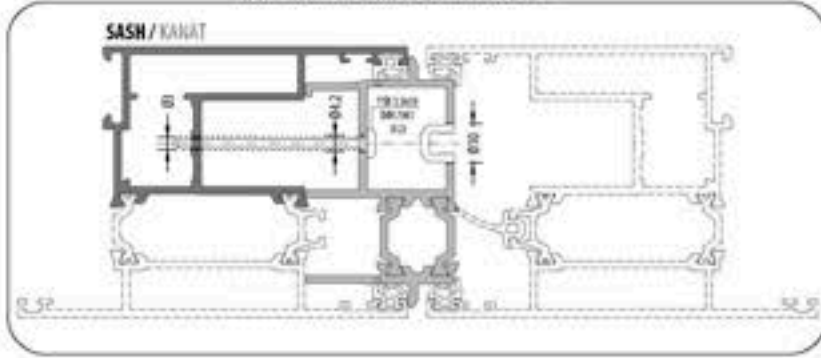

FOUR SASH ACCESSORIES ASSEMBLY / DÖRT KANAT AKSESUAR MONTAJI

70LS-503-00

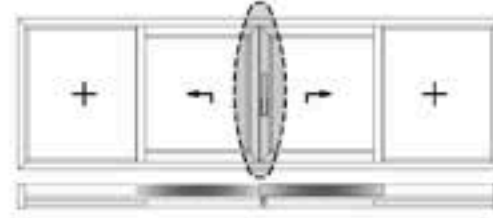

CUTTING DIMENSION / KESİM ÖLÇÜLERİ

70LS-503-00

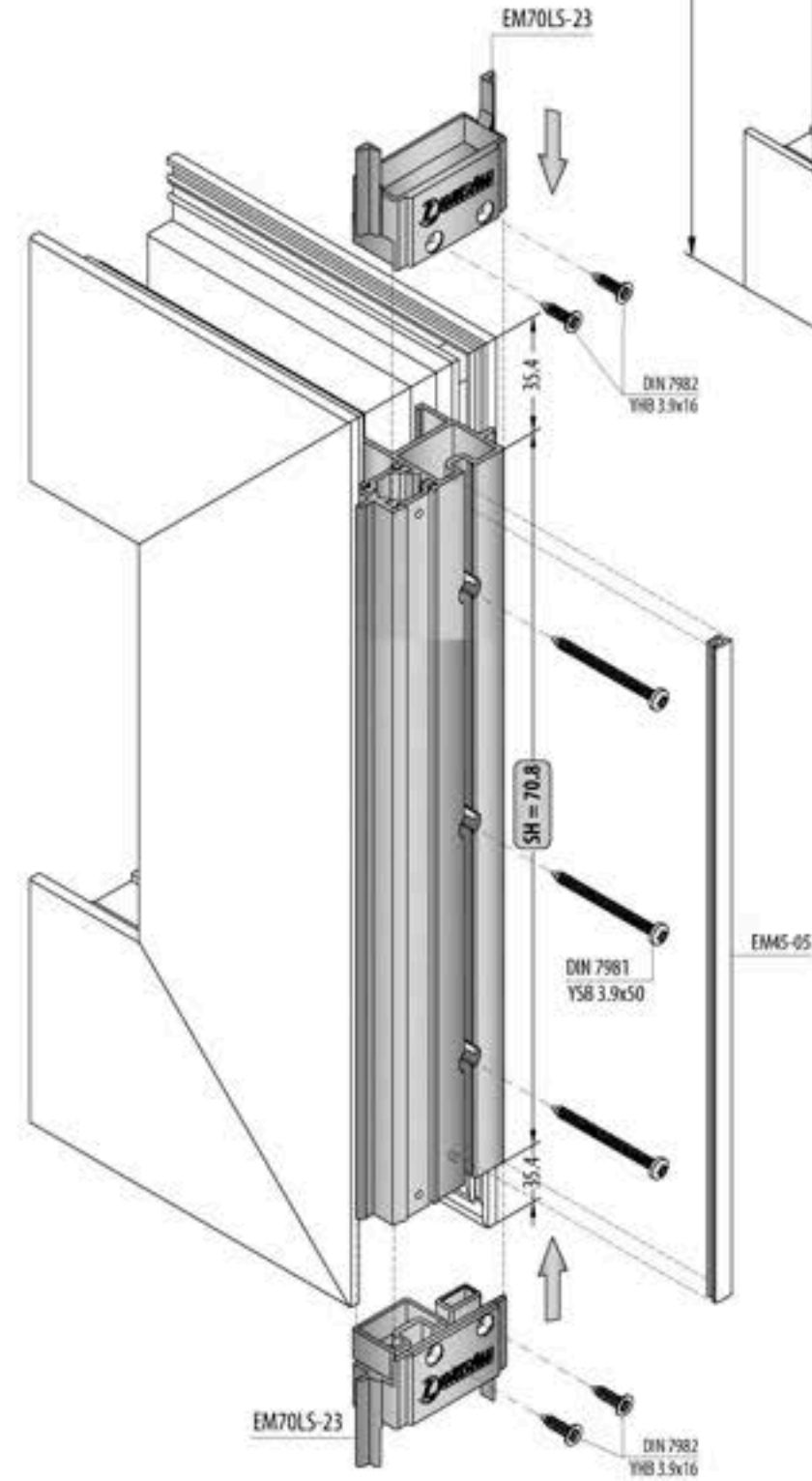
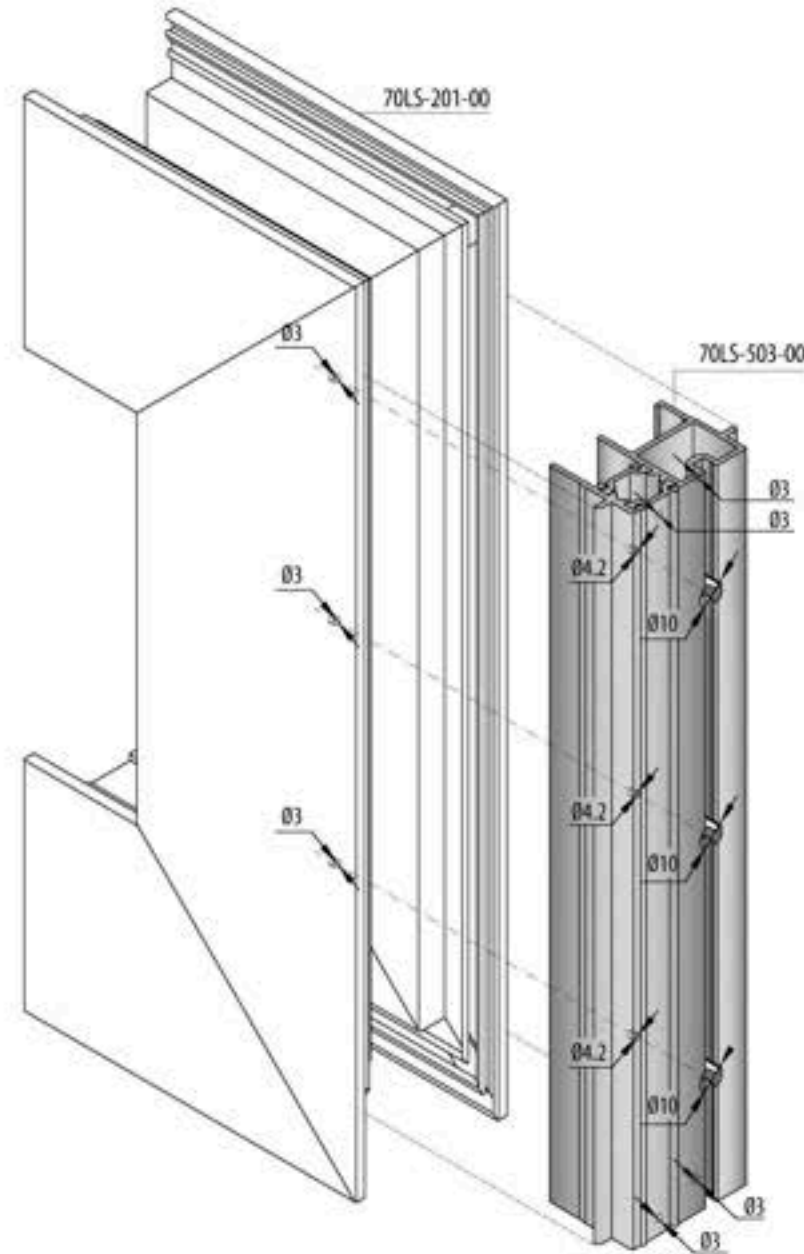
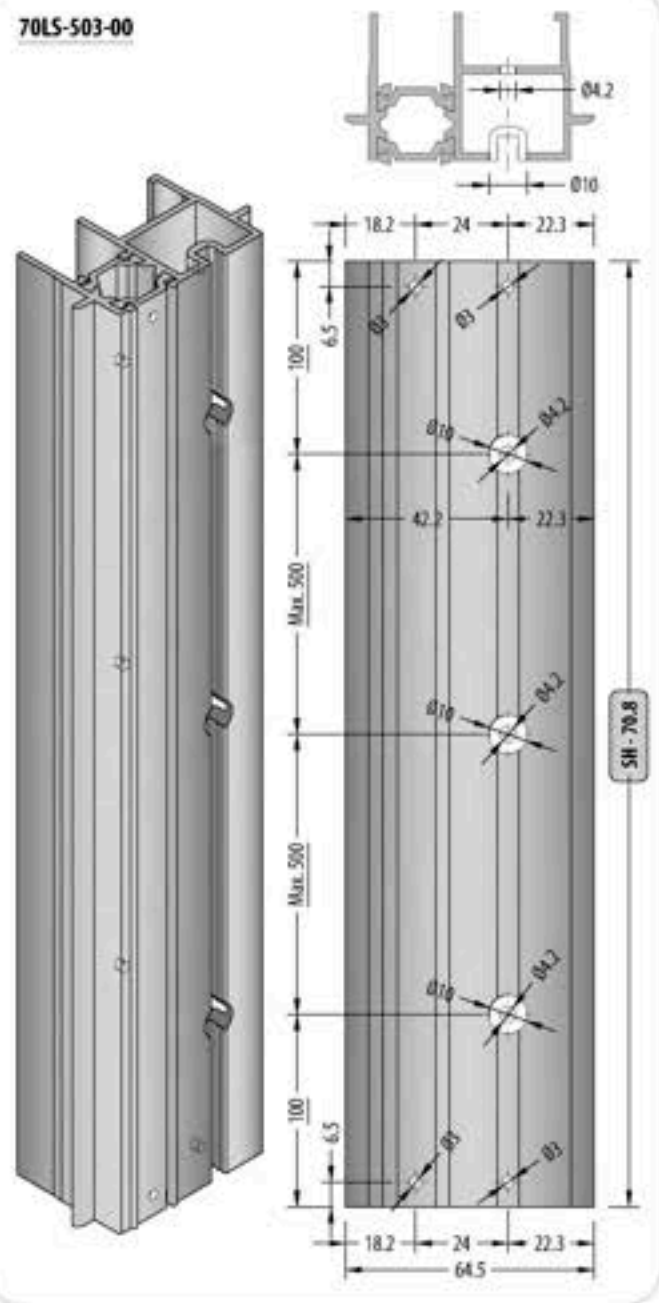

SASH & MULLION PROFILE ASSEMBLY
 KANAT & ORTA KAYIT PROFİL MONTAJI

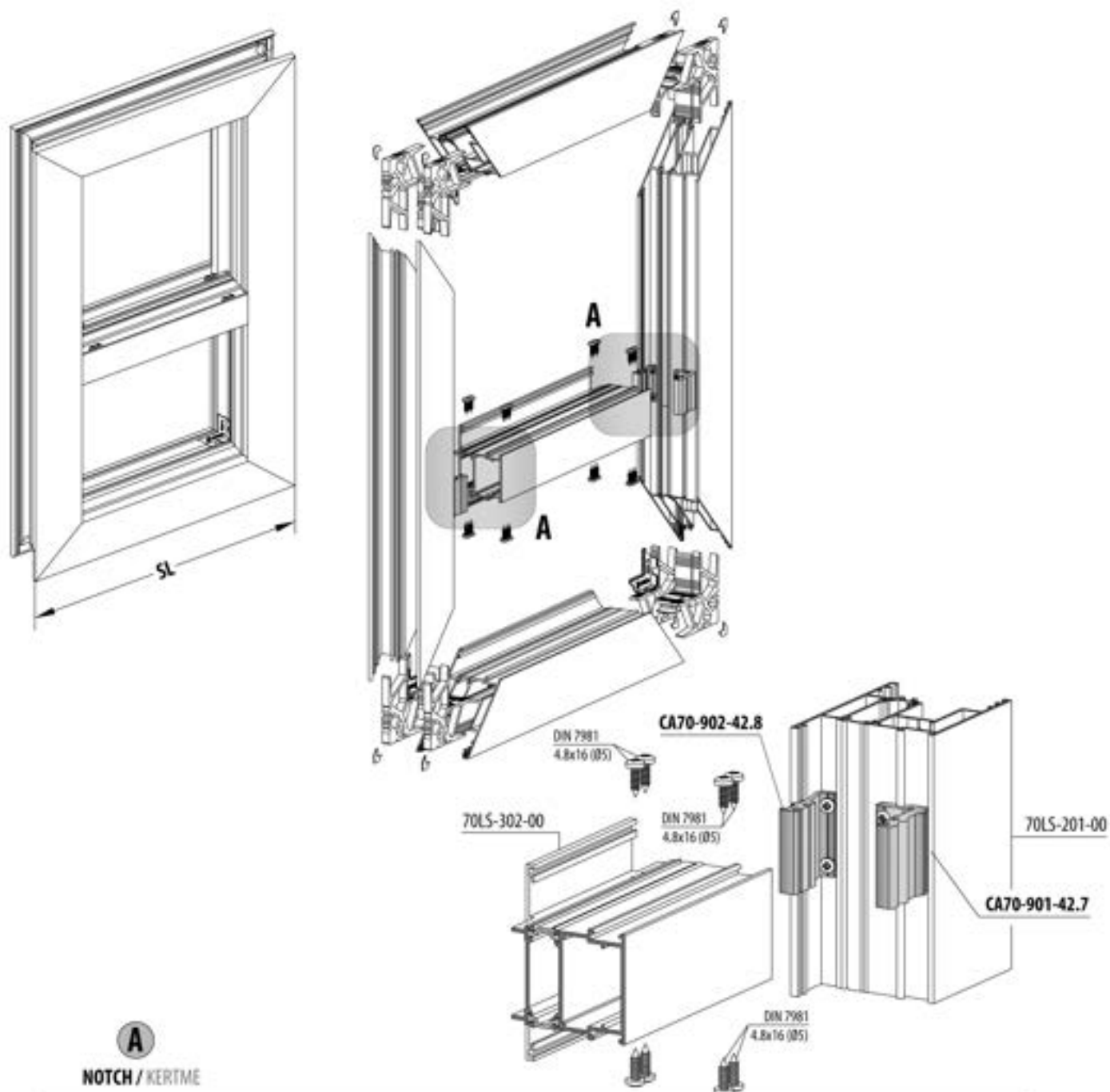

A

NOTCH / KERTME

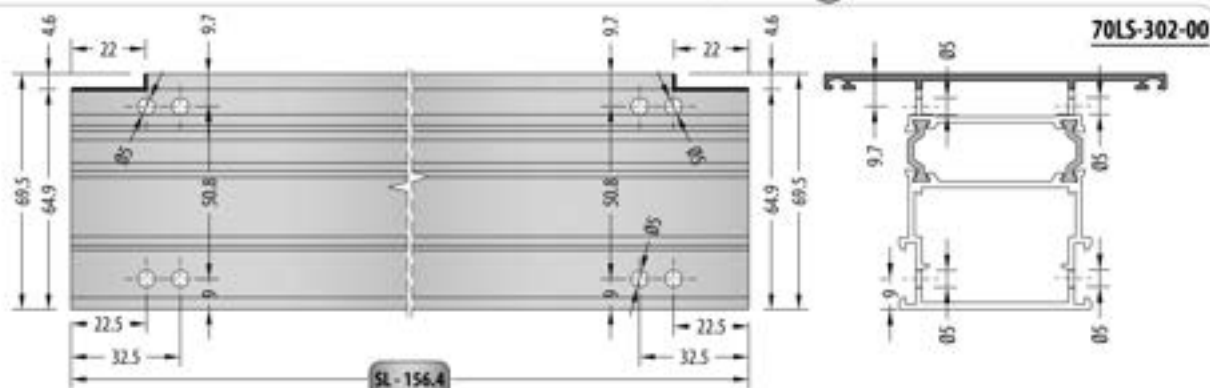

SL-156.A

FOUR SASH ACCESSORIES ASSEMBLY / DÖRT KANAT AKSESUAR MONTAJI

FLY SCREEN DRAINAIGE / SİNEKLİK TAHLİYE

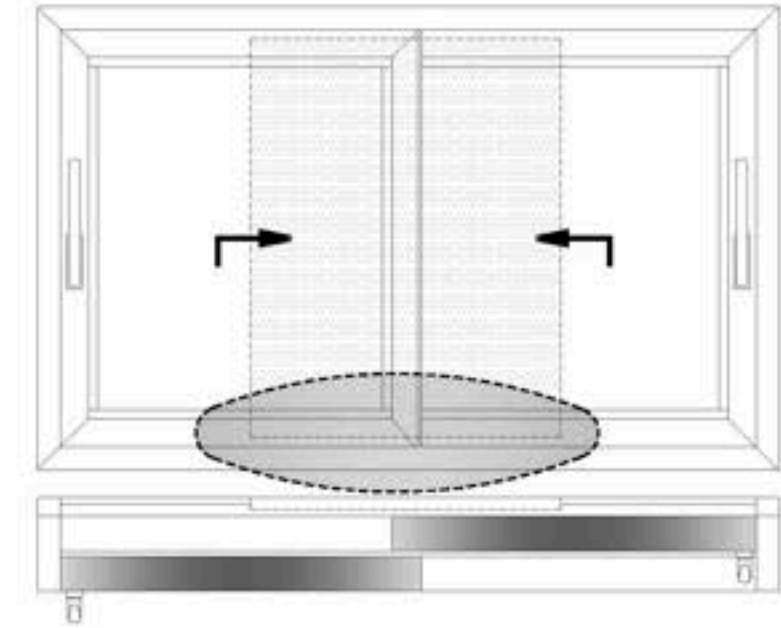
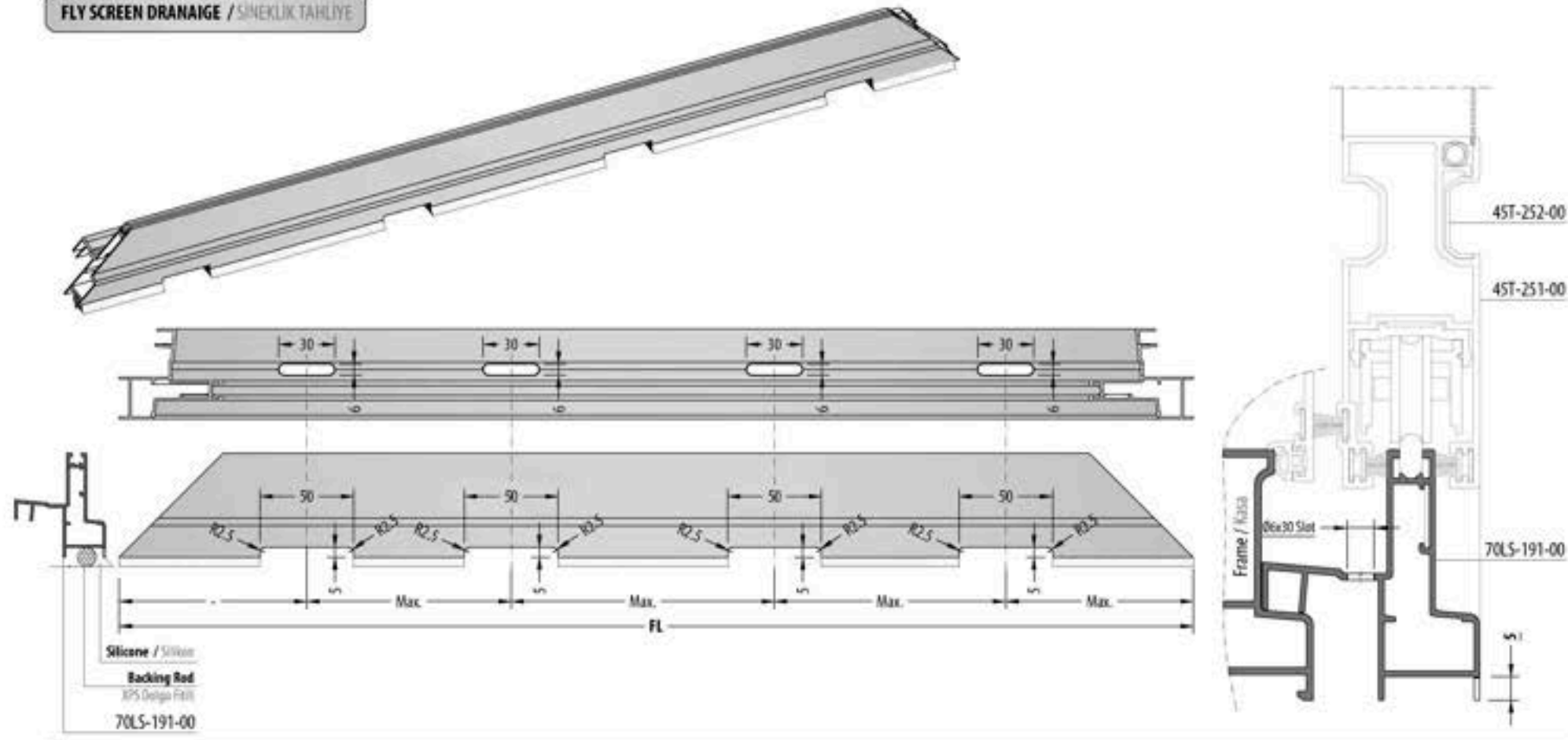

FLY SCREEN FRAME MONTAGE SCREW DRAINAIGE / SİNEKLİK KASA MONTAJ VIDALARI

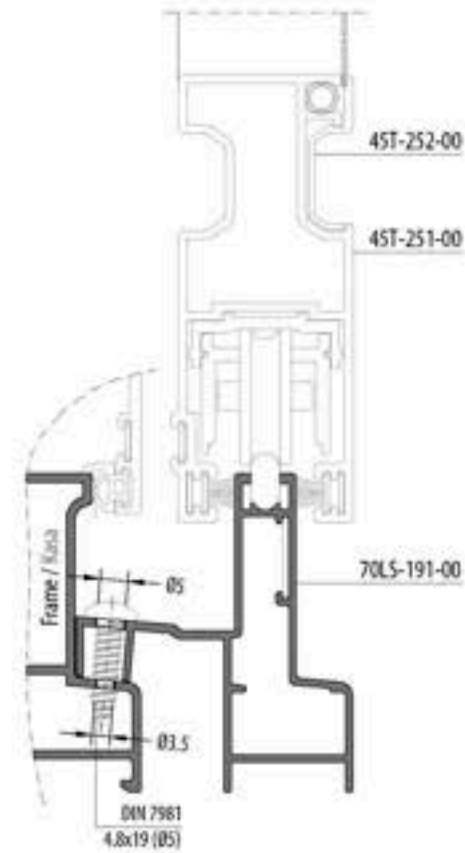
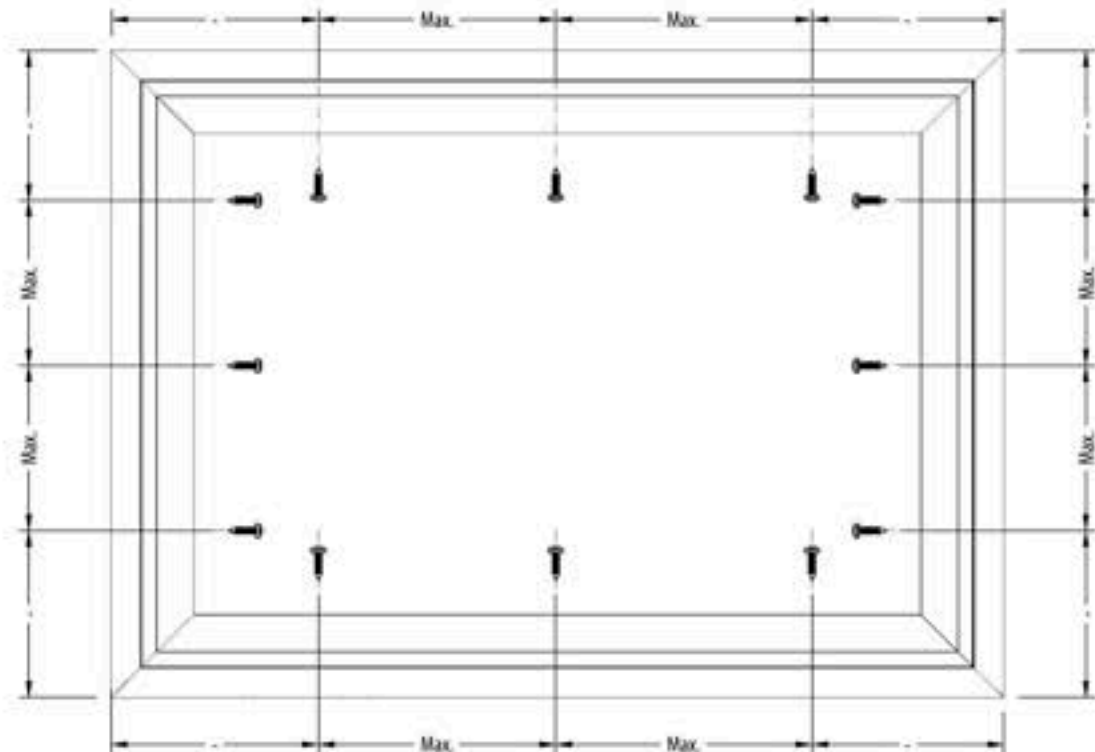

TWO RAIL FRAME / İKİ RAYLI KASA

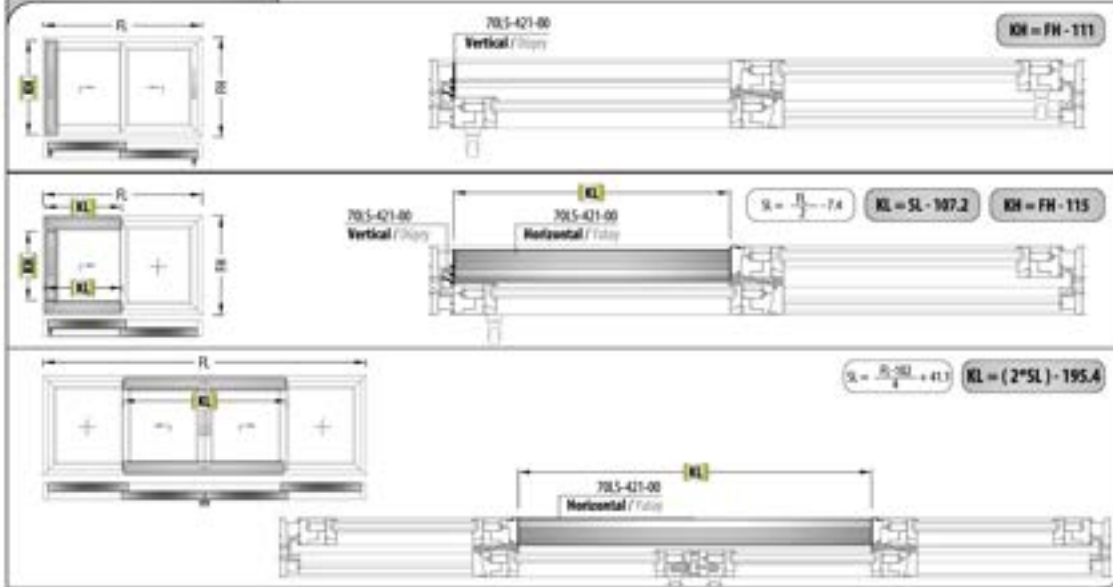

THREE RAIL FRAME / ÜÇ RAYLI KASA

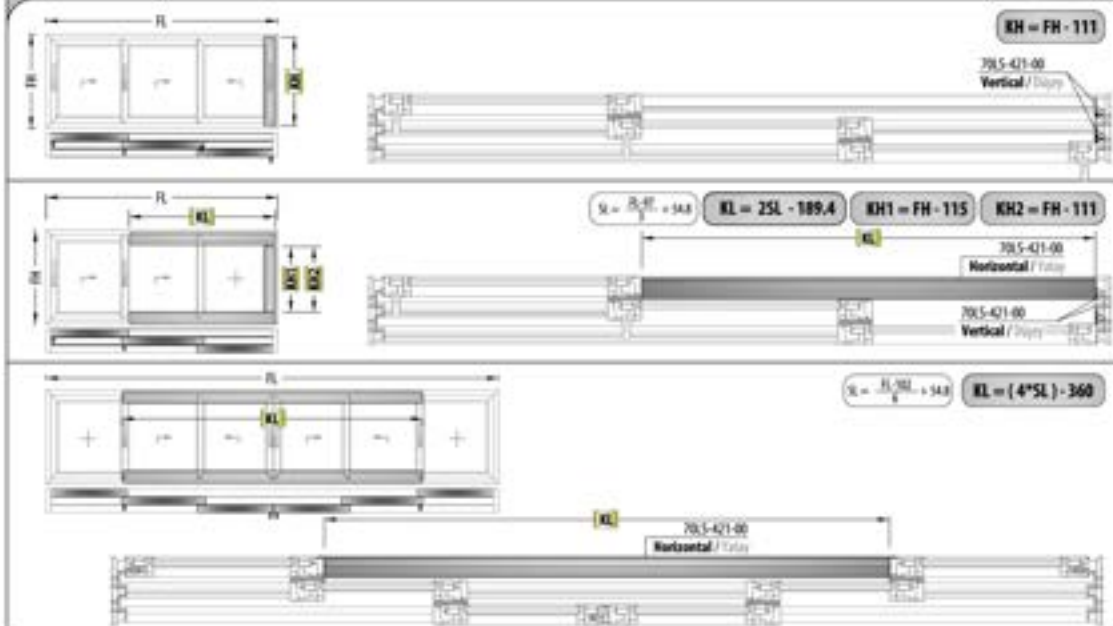

CAP ASSEMBLY / KAPAK MONTAJ

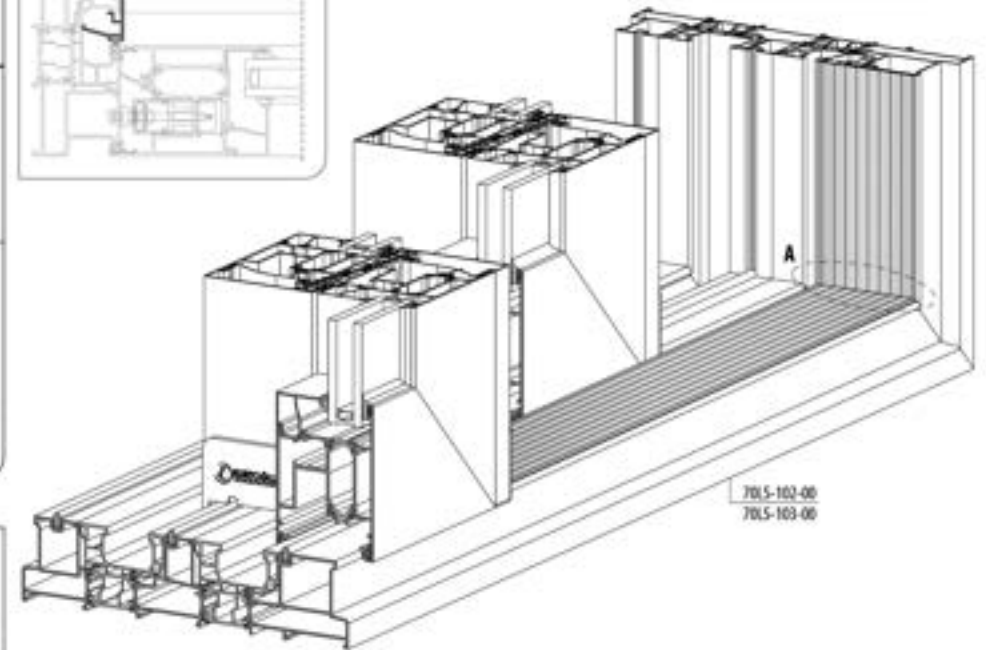

The vertical profile overlaps the horizontal profile.
Düsey profil yatay profilin üzerine geliyor.

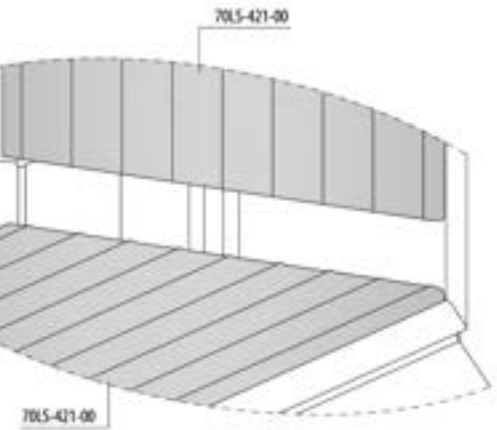

A DETAIL
A DETAYI

