

EDITION / VERSİYON
12/2010



TRAILER PROFILES

TIR PROFİLLERİ

 **Lorenzoline**[®]
aluminium profile system

company information

The company started its work life with copper and lead casting in the 1960s and in the 1980s we started to serve in The Aluminium Sector with a 1200 ton capacity aluminium extrusion press.

KURTOĞLU Aluminium is located in Corlu, approximately 100 km faraway from Istanbul and it operates in 22.000 m2 closed, 11.000 m2 open area.

According to our latest investments the company has become a full modern integrated aluminium extrusion company;

- Increasing its annual production capacity to ~ 34.000 tons,
- Working with ~ 400 qualified employers,
- Using the ISO 9001:2000 Management System.

The company's main production features are described as below:

- Tool Building,
- Aluminium Extrusion Presses, (800 ton , 1460 ton, 1880 ton, 1880 ton , 2100 ton and 2700 ton),
- Anodized Facilities (According to Qualanod Standards), Capacity 91.000 A.
- Powder Coating Facilities (According to Qualicoat Standards),
- Mechanical (CNC Applications) Treatments.

Kurtoglu Aluminium export its products to Switzerland, Germany, Austria, Greece, Cyprus, Bulgaria, Russian Federation, Ukraine, Lithuania, Moldavia, Serbia, Montenegro, Hungary, Iran, Iraq, Armenian, Kazakhstan, Macedonia, Albanian, Romania, Georgian. Using the ISO 9001:2000 Management System as a base Kurtoglu Aluminium continue the drive towards zero defect for all customers.

firmamız hakkında

Şirketimiz 1960' lı yıllarda Bakır ve Kurşun ile üretim hayatına başlamıştır. 1980 yılında 1200 tonluk Alüminyum Ekstrüzyon presi ile üretim sektörüne girmiştir.

KURTOĞLU Alüminyum İstanbul'a yaklaşık 100 km mesafede Çorlu'da bulunmaktadır. 22.000 m2 kapalı 11.000 m2 açık alanda faaliyetini sürdürmektedir. Son yapılan yatırımlarla şirketimiz modern bir entegre tesise haline ulaşmıştır.

Şirketimizin ana özellikleri aşağıda da belirtilmiştir:

- Yıllık kapasite ~ 34.000 ton,
- Yaklaşık ~ 400 kalifiye eleman,
- ISO 9001:2000 kalite sistemi,
- Qualicoat Belgesi,
- Qualanod Belgesi,
- CE Belgesi,
- Kalıphane Bölümü (Tel erozyon, İşleme Merkezi)
- Alüminyum Ekstrüzyon Presleri; (800 ton, 1460 ton, 1880 ton, 1880 ton ve 2600 ton),
- Eloksal Tesisi (91.000 Amper)
- Elektrostatik Toz Boya Tesisi
- Mekanik İşlem Bölümü (CNC İşleme Merkezi)

KURTOĞLU Alüminyum ürünleri; İsviçre, Almanya, Avusturya, Yunanistan, Kıbrıs, Bulgaristan, Rusya Federasyonu, Ukrayna, Litvanya, Moldova, Sırbistan, Karadağ, Macaristan, İran, Irak, Ermenistan, Makedonya, Arnavutluk, Romanya ve Gürcistan'a ihraç edilmektedir.

KURTOĞLU ALÜMİNYUM müşterilerine sıfır hata ile hizmet vermeyi temel olarak çalışmalarını sürdürmektedir.

quality policy

The company's quality policy is based upon the pillars of product quality, state-of-the-art technology, customer satisfaction, training, environmental concerns, and continuous development. Kurtoglu always implements this policy in all of its operations and units.

kalite politikası

Şirketin kalite politikası ürün kalitesine, yeni teknolojilere , müşteri memnuniyetine , eğitime , çevre duyarlılığına ve sürekli gelişime dayanır.

Kurtoglu, her zaman tüm faaliyet ve birimlerinde bu politikayı uygular.

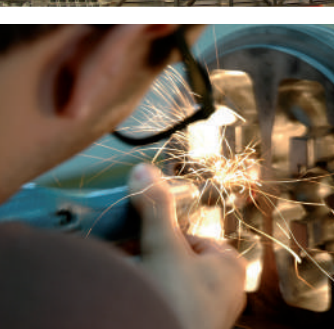
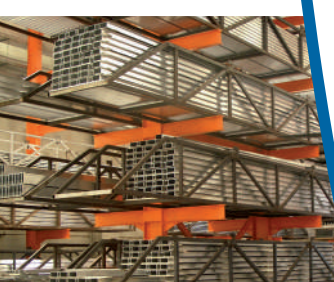

tırprofilleri

truckprofiles

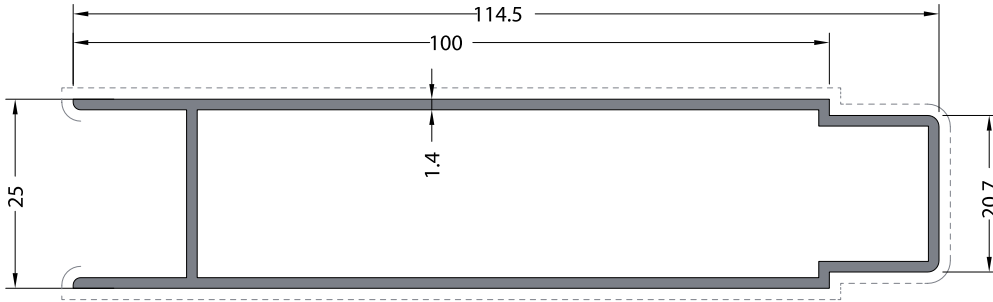

CODE / KOD **THEORETICAL WEIGHT kg/m**
901 *TEORİK AĞIRLIK kg/m*
1.033

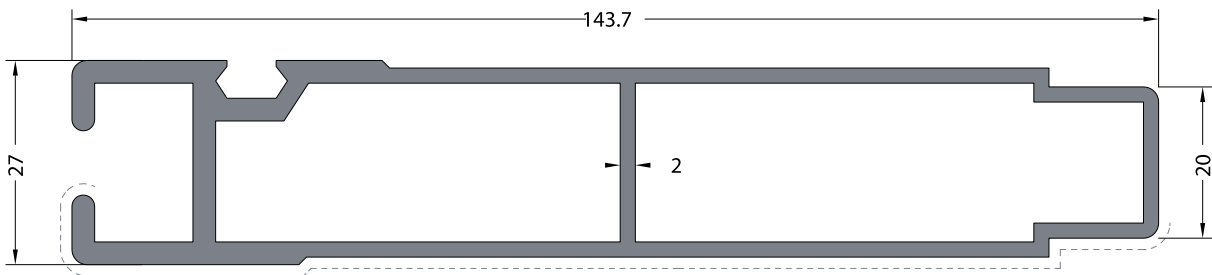

CODE / KOD **THEORETICAL WEIGHT kg/m**
902 *TEORİK AĞIRLIK kg/m*
2.277

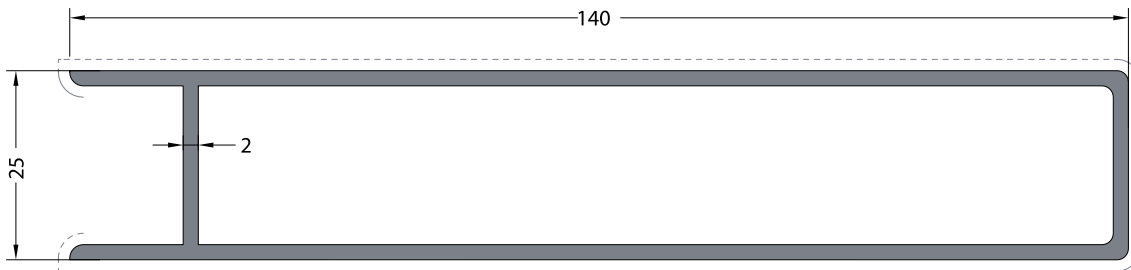

CODE / KOD **THEORETICAL WEIGHT kg/m**
903 *TEORİK AĞIRLIK kg/m*
1.741

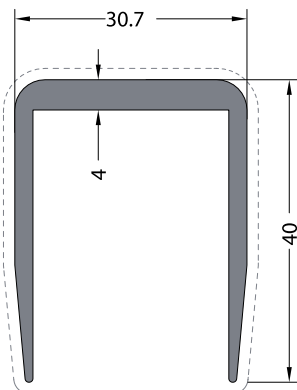

CODE / KOD
904
THEORETICAL WEIGHT kg/m
TEORİK AĞIRLIK kg/m
0.711

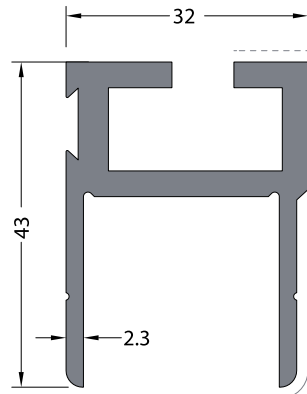

CODE / KOD
906
THEORETICAL WEIGHT kg/m
TEORİK AĞIRLIK kg/m
1.050

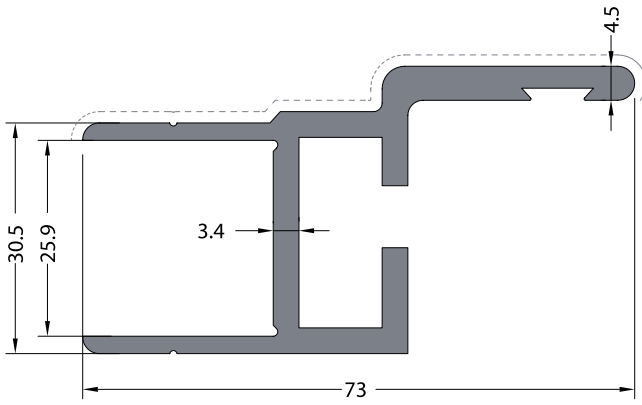

CODE / KOD **THEORETICAL WEIGHT kg/m**
905 *TEORİK AĞIRLIK kg/m*
1.398

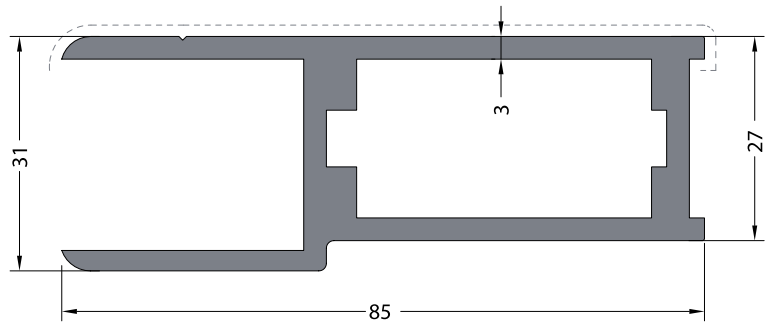

CODE / KOD **THEORETICAL WEIGHT kg/m**
909 *TEORİK AĞIRLIK kg/m*
1.933

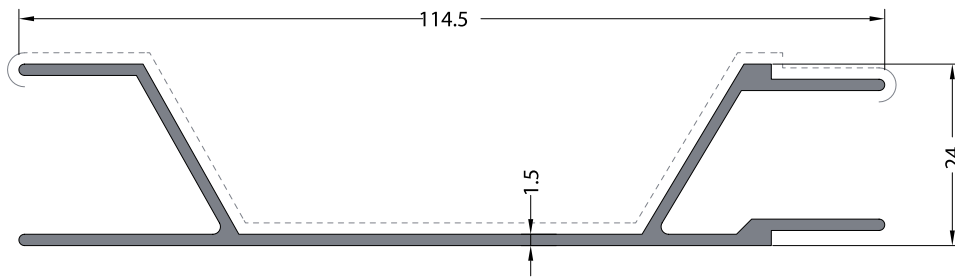

CODE / KOD **THEORETICAL WEIGHT kg/m**
907 *TEORİK AĞIRLIK kg/m*
0.848

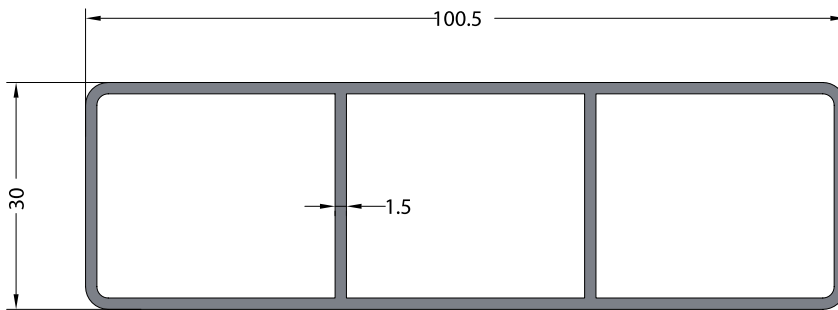

CODE / KOD **THEORETICAL WEIGHT kg/m** koruyucueloksal / protectiveanodized
908 *TEORİK AĞIRLIK kg/m*
1.240

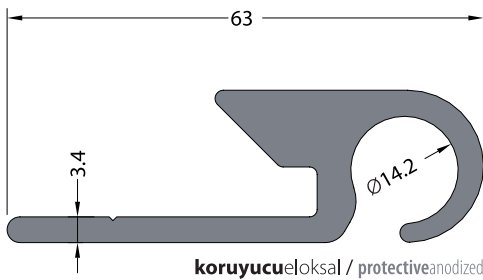

CODE / KOD **THEORETICAL WEIGHT kg/m**
910 *TEORİK AĞIRLIK kg/m*
1.223

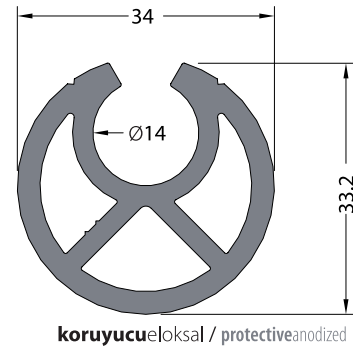

CODE / KOD **THEORETICAL WEIGHT kg/m**
911 *TEORİK AĞIRLIK kg/m*
1.166

tırprofilleri / truckprofiles

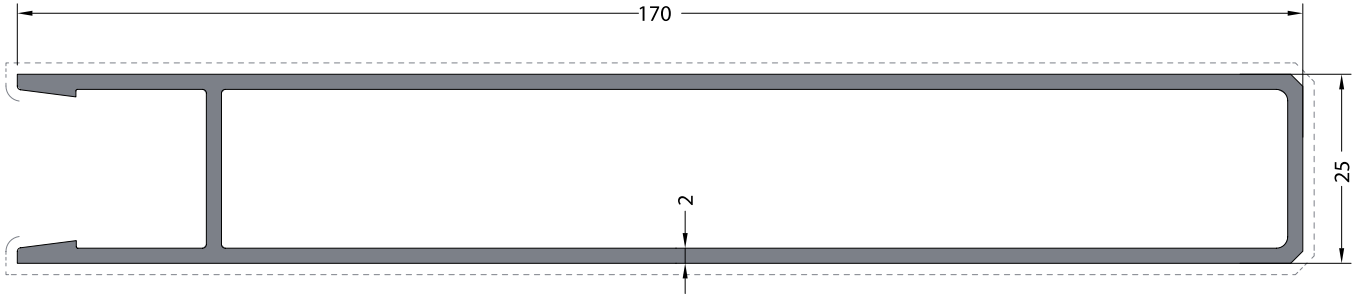

CODE / KOD **THEORETICAL WEIGHT kg/m**
912 *TEORİK AĞIRLIK kg/m*
2.088

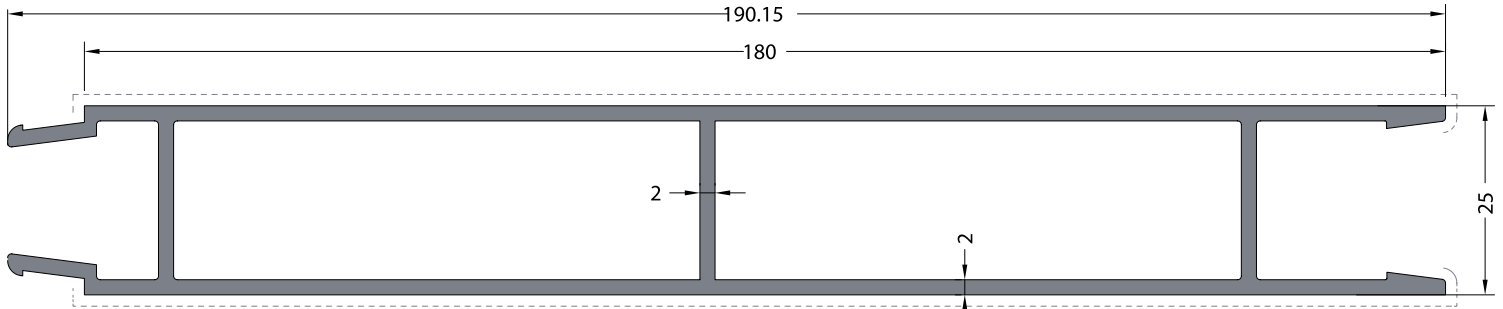

CODE / KOD **THEORETICAL WEIGHT kg/m**
913 *TEORİK AĞIRLIK kg/m*
2.448

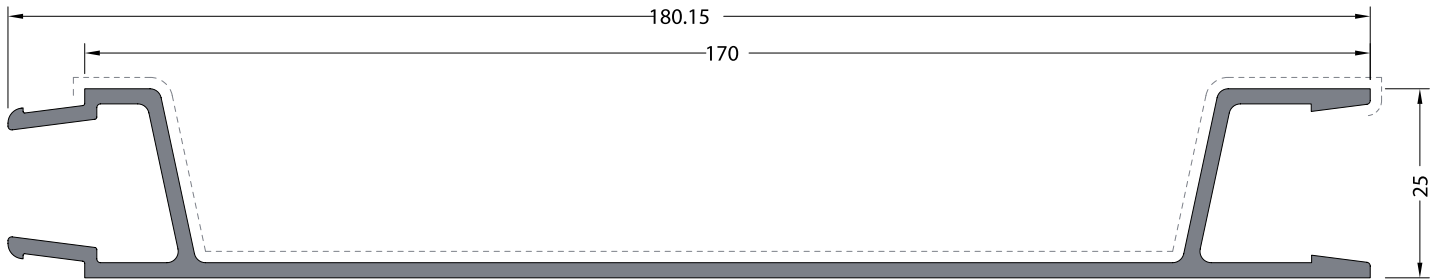

CODE / KOD **THEORETICAL WEIGHT kg/m**
914 *TEORİK AĞIRLIK kg/m*
1.478

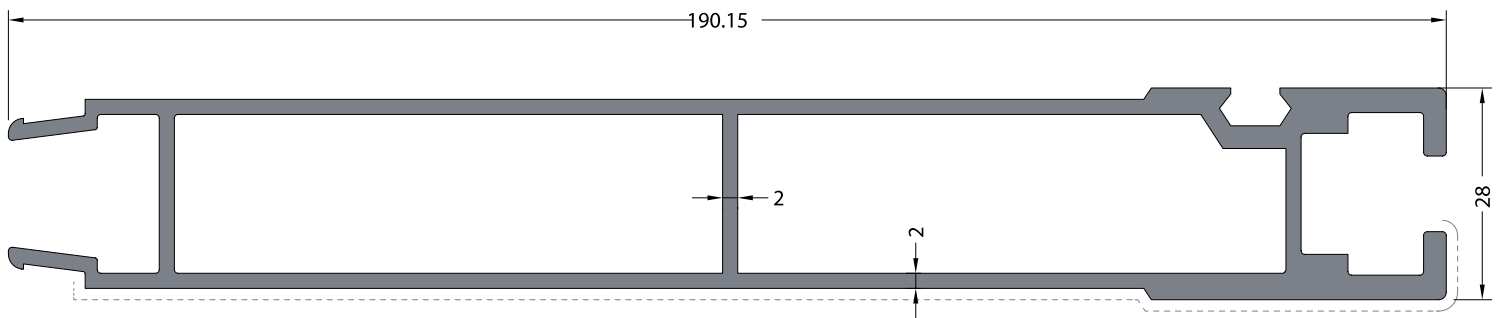

CODE / KOD **THEORETICAL WEIGHT kg/m**
915 *TEORİK AĞIRLIK kg/m*
2.921

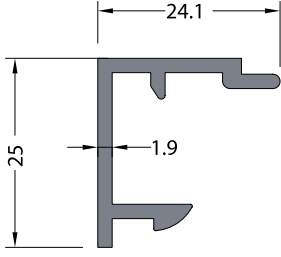

görünenüzeyyoktur / novisiblesurface

CODE / KOD THEORETICAL WEIGHT kg/m
916 TEORİK AĞIRLIK kg/m
0.334

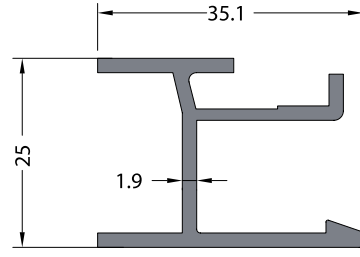

görünenüzeyyoktur / novisiblesurface

CODE / KOD THEORETICAL WEIGHT kg/m
917 TEORİK AĞIRLIK kg/m
0.505

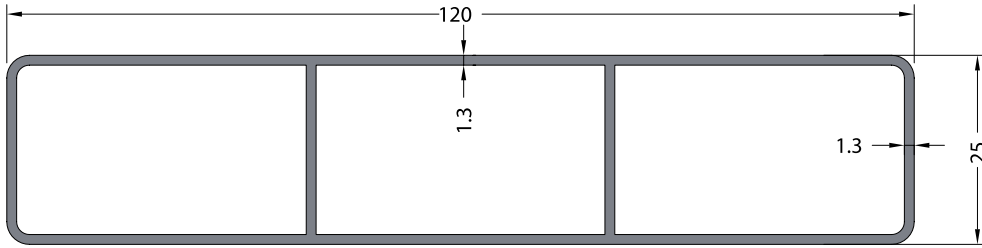

CODE / KOD THEORETICAL WEIGHT kg/m
918 TEORİK AĞIRLIK kg/m
1.147

koruyucueloksal / protectiveanodized

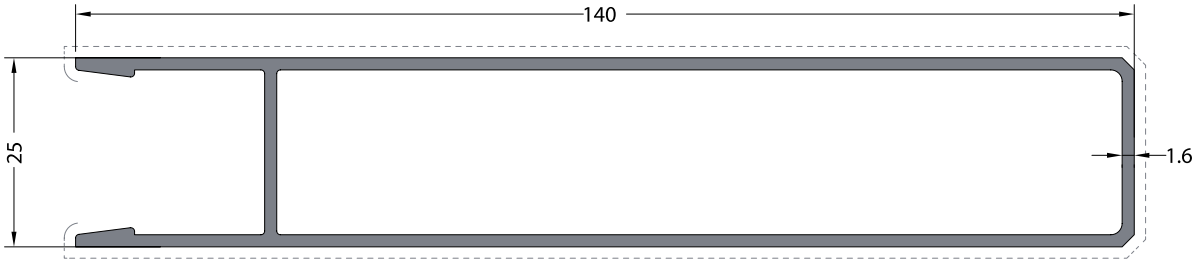

CODE / KOD THEORETICAL WEIGHT kg/m
919 TEORİK AĞIRLIK kg/m
1.418

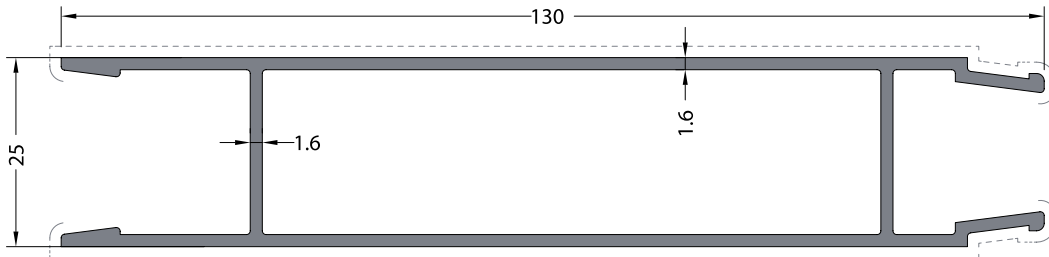

CODE / KOD THEORETICAL WEIGHT kg/m
920 TEORİK AĞIRLIK kg/m
1.361

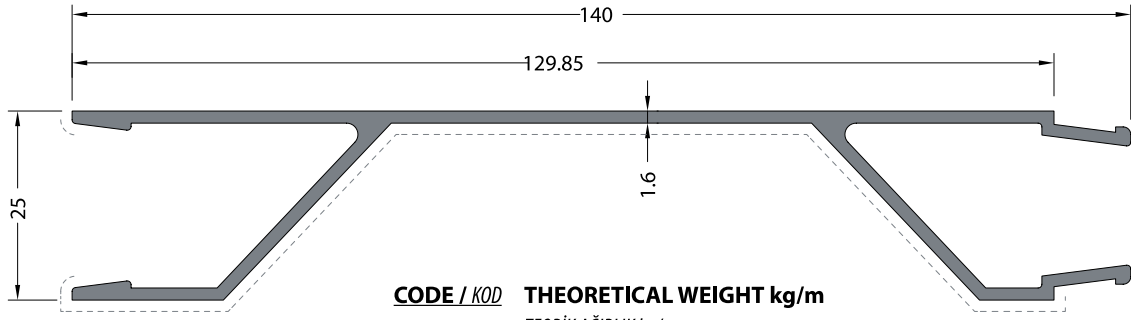

CODE / KOD THEORETICAL WEIGHT kg/m
921 TEORİK AĞIRLIK kg/m
1.126

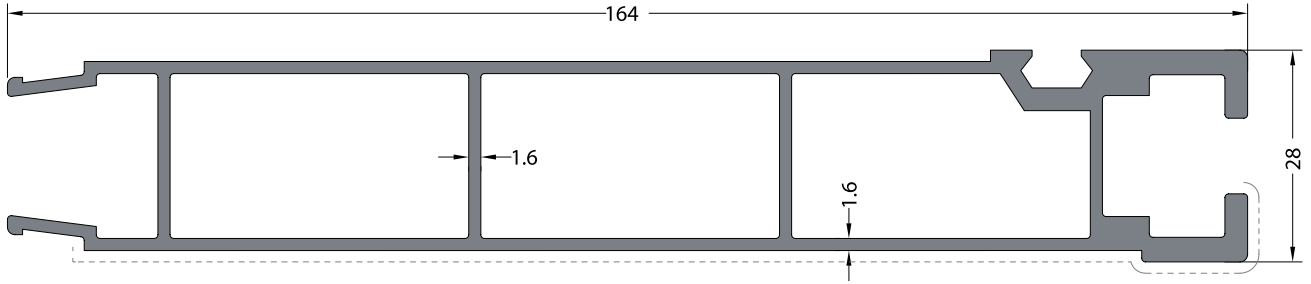

CODE / KOD THEORETICAL WEIGHT kg/m
922 TEORİK AĞIRLIK kg/m
2.253

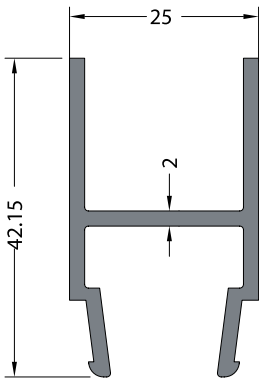

görünen yüzey yoktur / no visible surface

CODE / KOD THEORETICAL WEIGHT kg/m
923 TEORİK AĞIRLIK kg/m
0.594

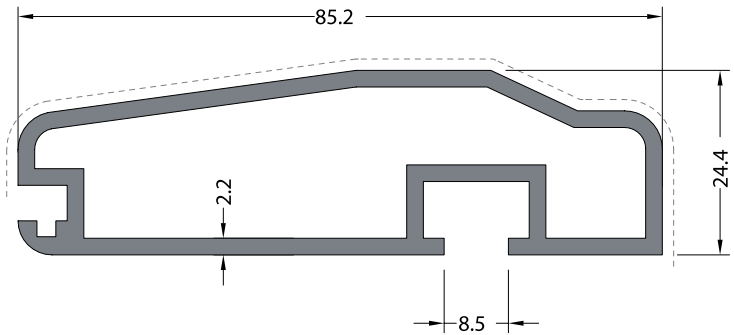

CODE / KOD THEORETICAL WEIGHT kg/m
924 TEORİK AĞIRLIK kg/m
1.381

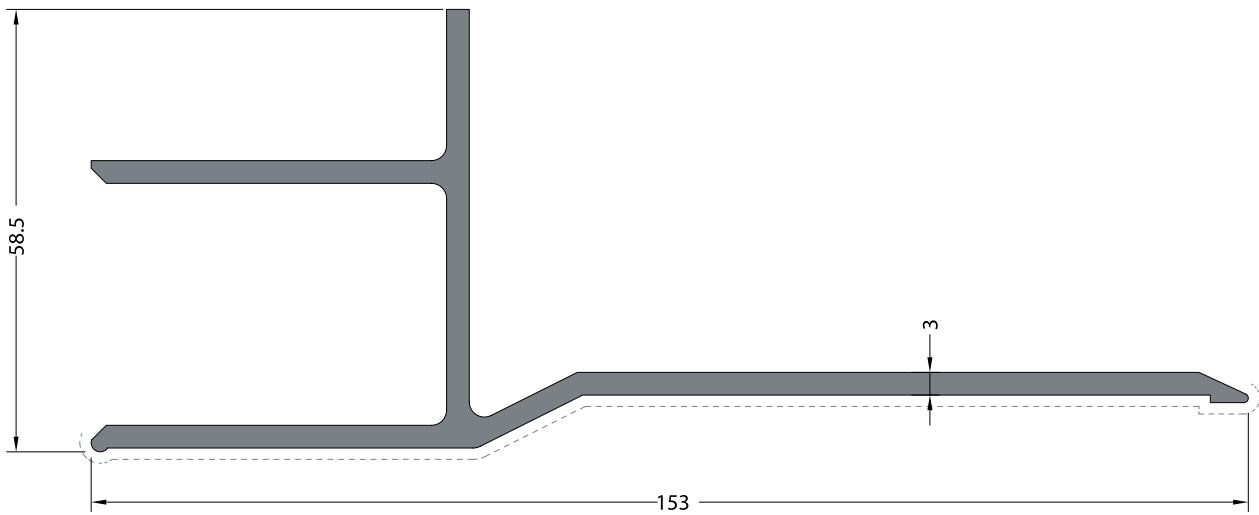

CODE / KOD **THEORETICAL WEIGHT kg/m**
925 *TEORİK AĞIRLIK kg/m*
2.077

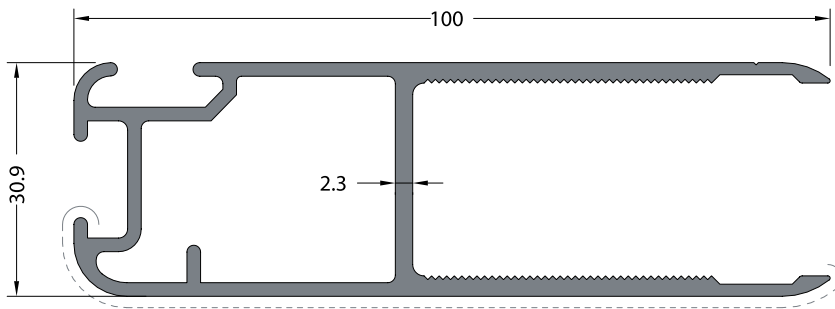

CODE / KOD **THEORETICAL WEIGHT kg/m**
926 *TEORİK AĞIRLIK kg/m*
1.533

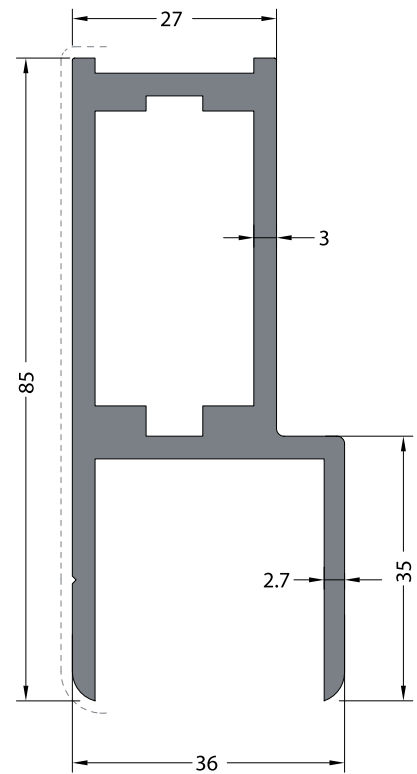

CODE / KOD
927
THEORETICAL WEIGHT kg/m
TEORİK AĞIRLIK kg/m
1.974

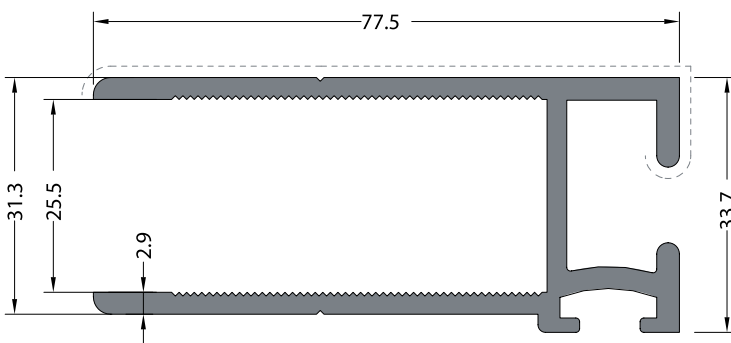

CODE / KOD **THEORETICAL WEIGHT kg/m**
937 *TEORİK AĞIRLIK kg/m*
1.506

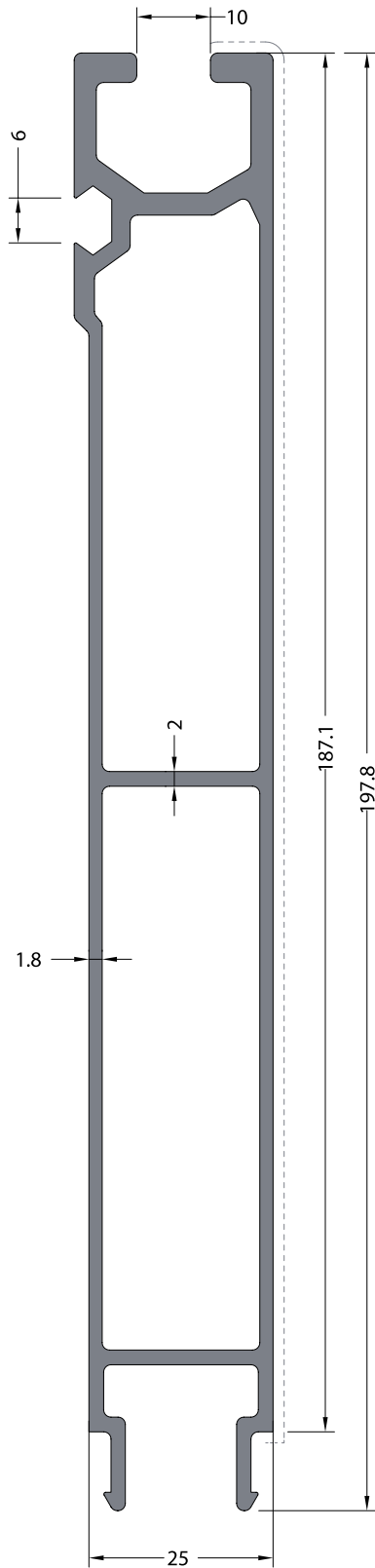

CODE / KOD

938

THEORETICAL WEIGHT kg/m

TEORİK AĞIRLIK kg/m

2.724

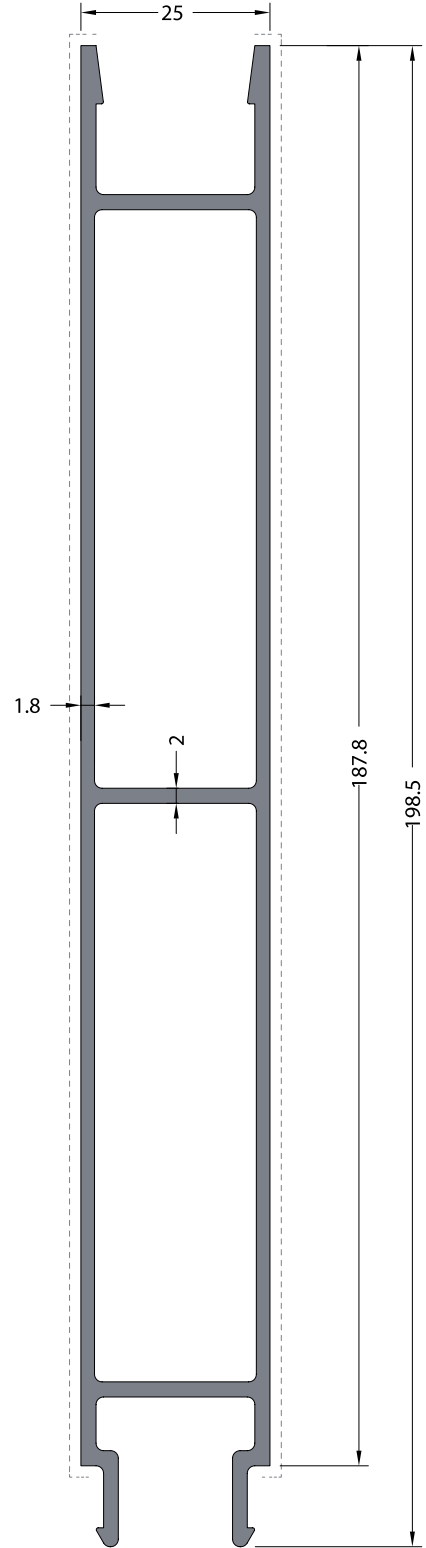

CODE / KOD

939

THEORETICAL WEIGHT kg/m

TEORİK AĞIRLIK kg/m

2.389

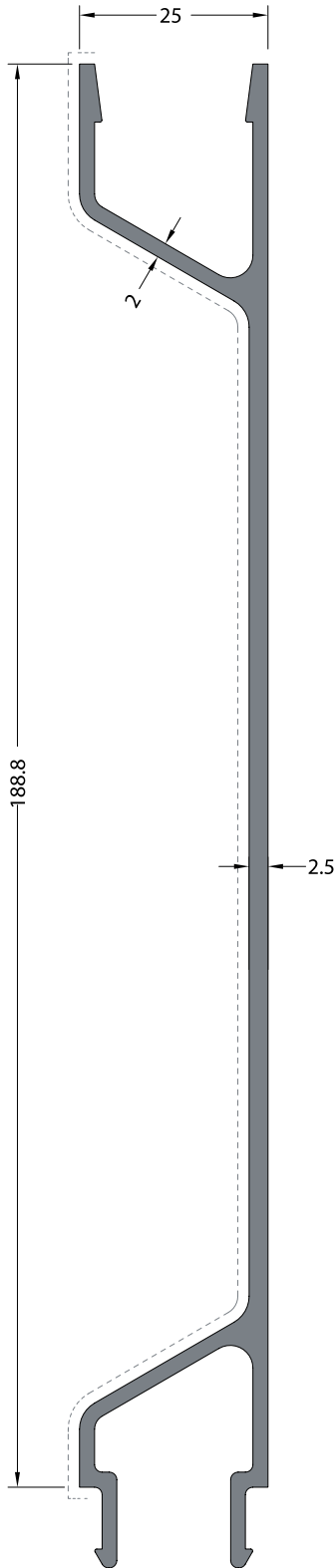

CODE / KOD **THEORETICAL WEIGHT kg/m**
940 *TEORİK AĞIRLIK kg/m*
1.845

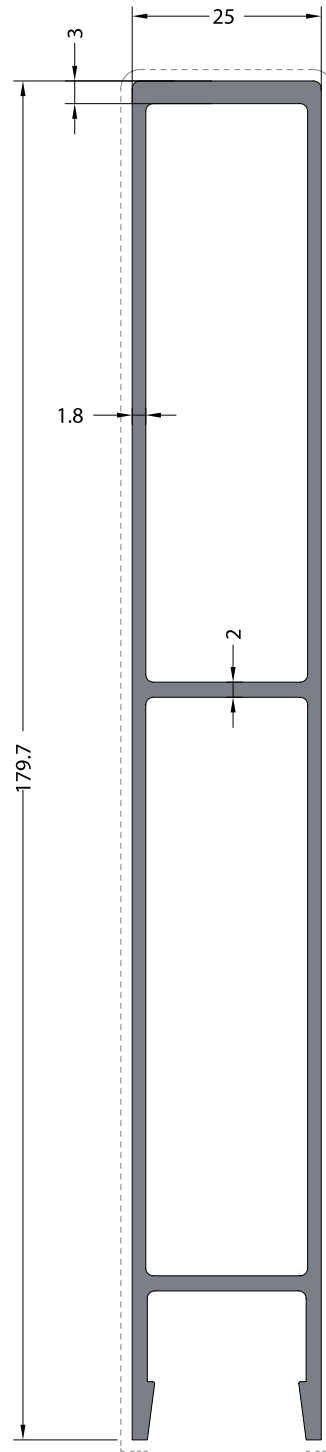

CODE / KOD **THEORETICAL WEIGHT kg/m**
941 *TEORİK AĞIRLIK kg/m*
2.206

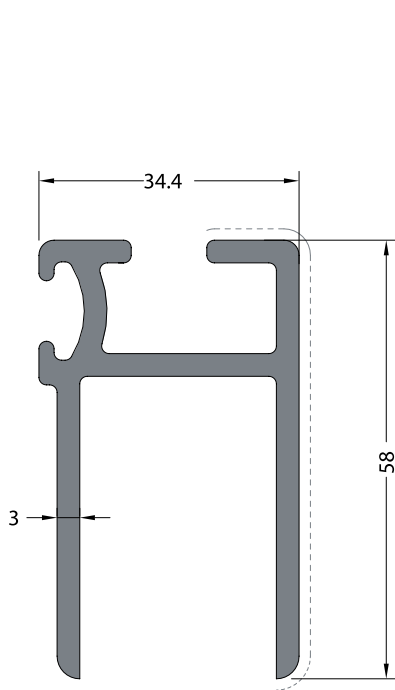

CODE / KOD THEORETICAL WEIGHT kg/m
942 TEORİK AĞIRLIK kg/m
1.337

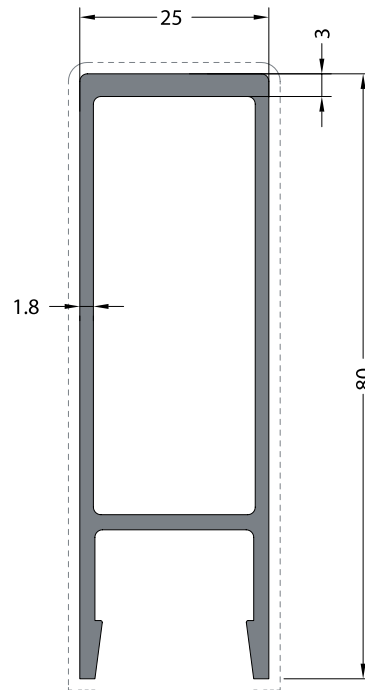

CODE / KOD THEORETICAL WEIGHT kg/m
943 TEORİK AĞIRLIK kg/m
1.115

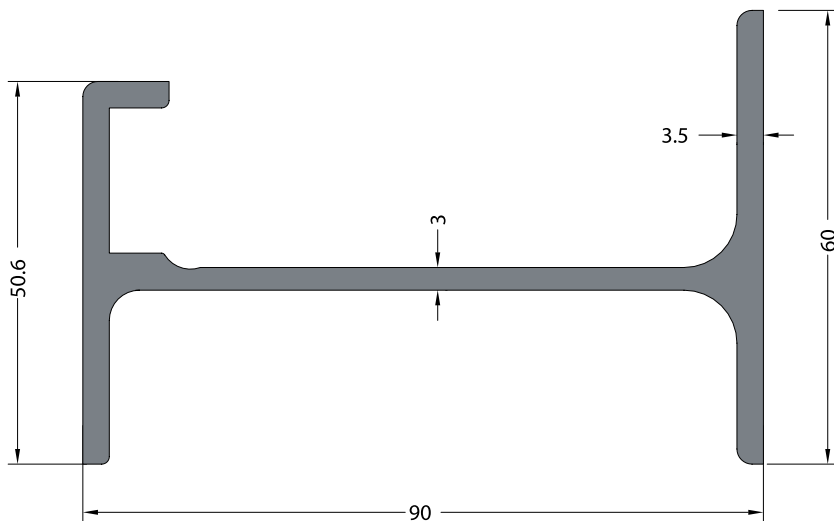

CODE / KOD THEORETICAL WEIGHT kg/m
944 TEORİK AĞIRLIK kg/m
1.897

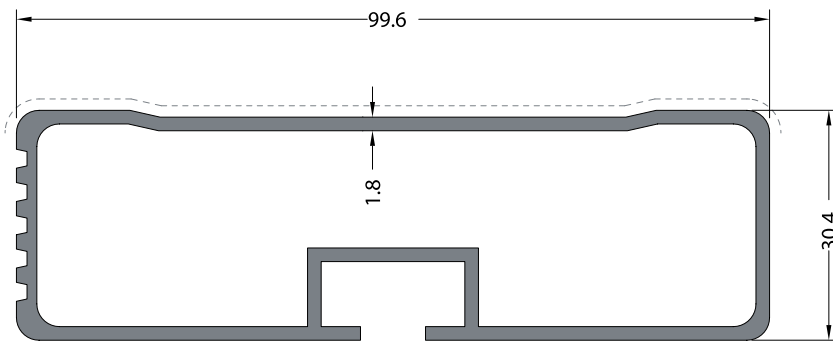
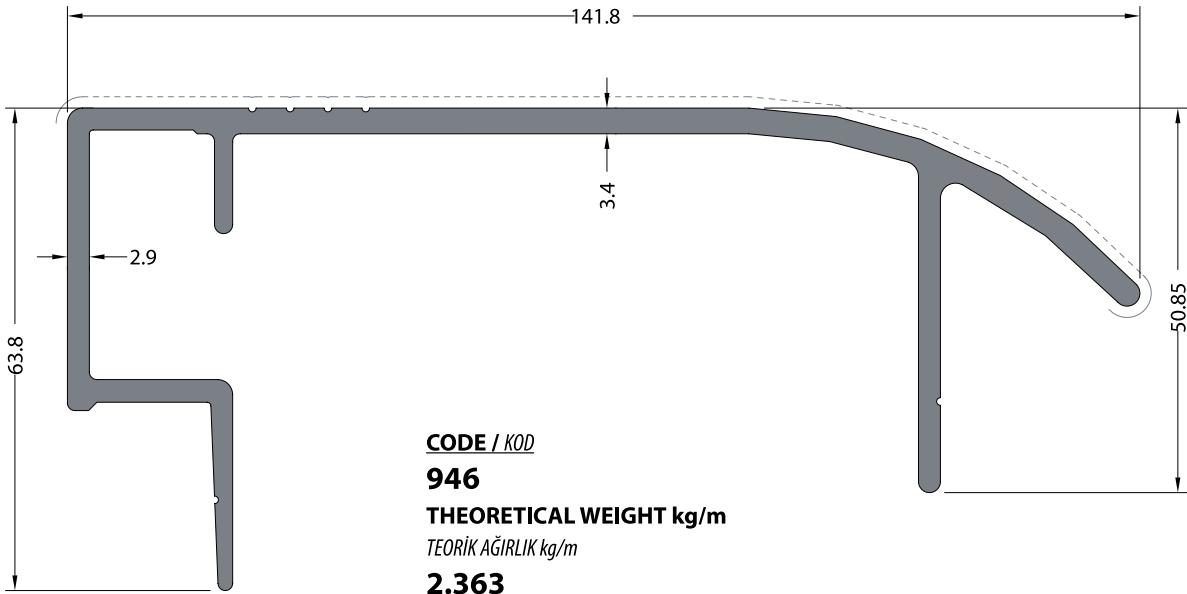

CODE / KOD
946
THEORETICAL WEIGHT kg/m
TEORİK AĞIRLIK kg/m
1.410

CODE / KOD
947
THEORETICAL WEIGHT kg/m
TEORİK AĞIRLIK kg/m
1.411

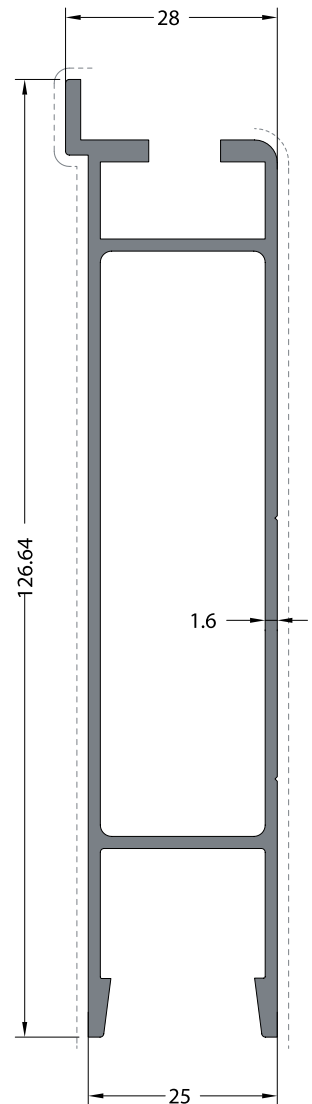

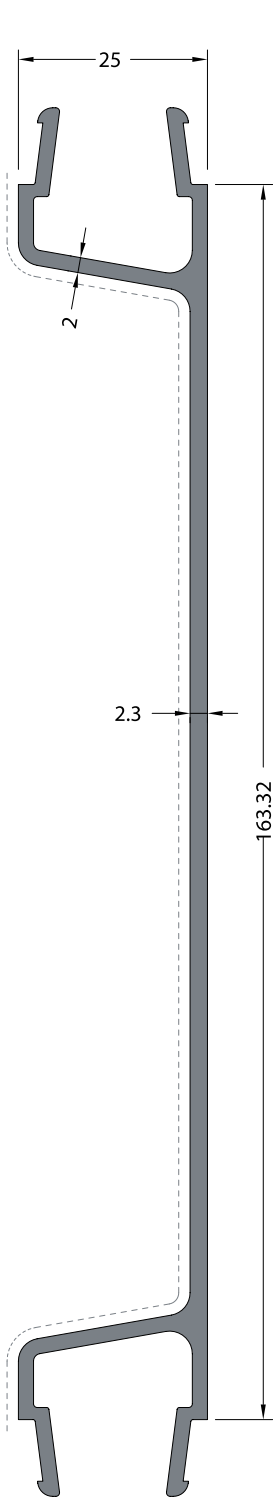

CODE / KOD
948
THEORETICAL WEIGHT kg/m
TEORİK AĞIRLIK kg/m
1.622

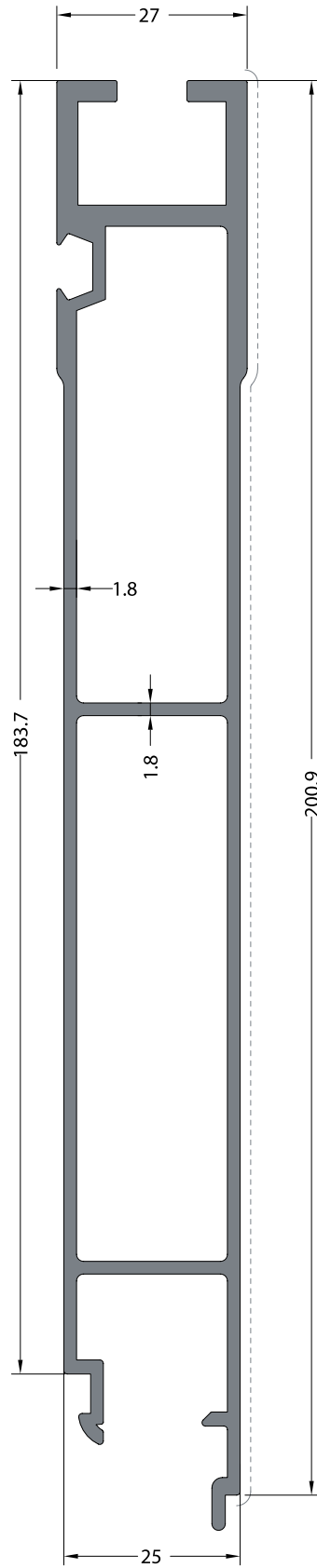

CODE / KOD
950
THEORETICAL WEIGHT kg/m
TEORİK AĞIRLIK kg/m
2.750

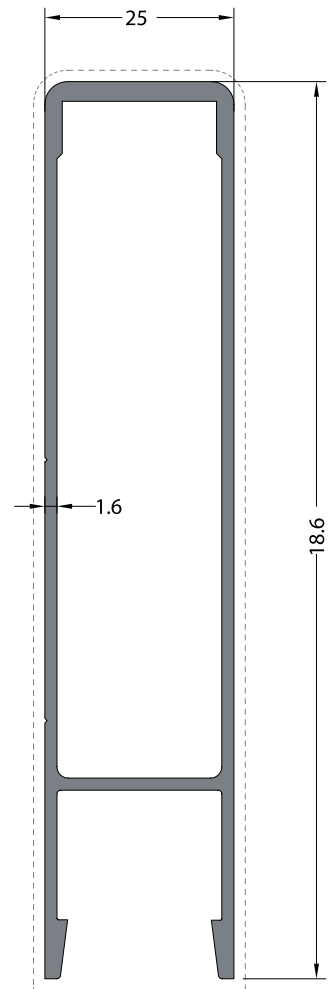

CODE / KOD
949
THEORETICAL WEIGHT kg/m
TEORİK AĞIRLIK kg/m
1.334

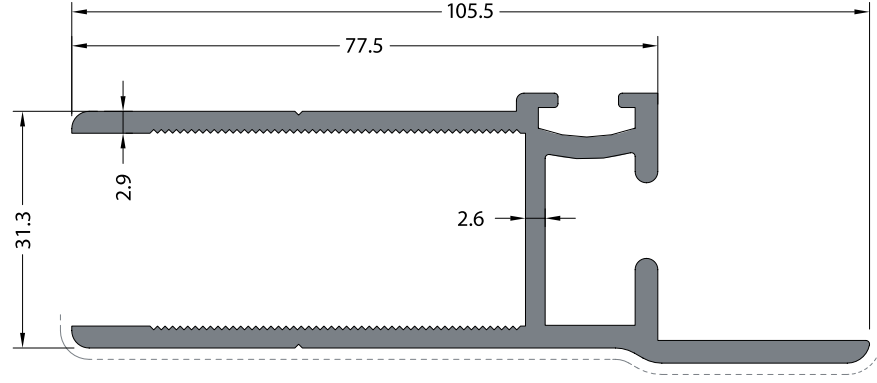

CODE / KOD THEORETICAL WEIGHT kg/m
951 TEORİK AĞIRLIK kg/m
1.742

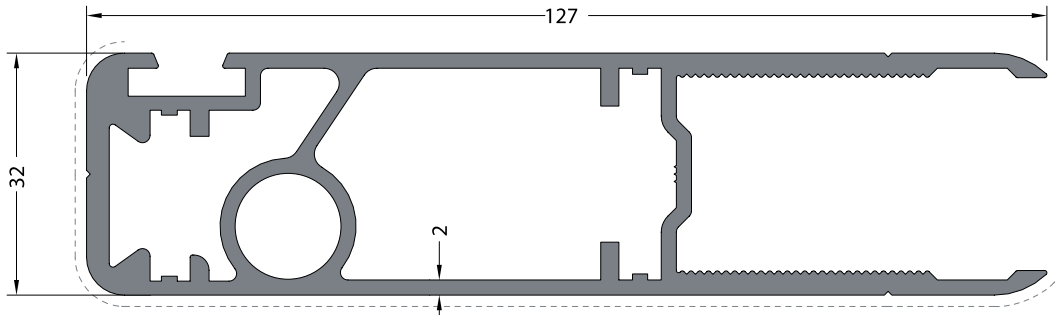

CODE / KOD THEORETICAL WEIGHT kg/m
952 TEORİK AĞIRLIK kg/m
2.550

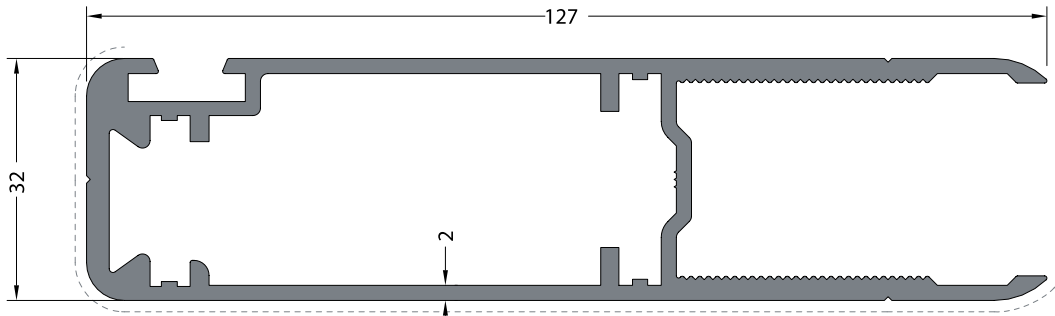

CODE / KOD THEORETICAL WEIGHT kg/m
953 TEORİK AĞIRLIK kg/m
2.229

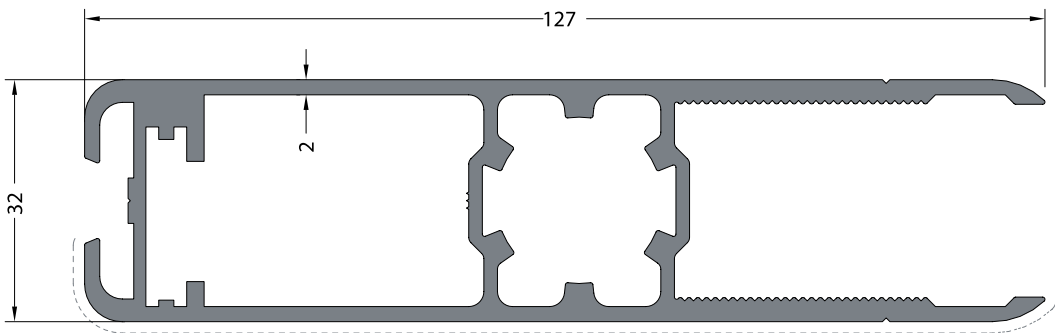

CODE / KOD THEORETICAL WEIGHT kg/m
954 TEORİK AĞIRLIK kg/m
2.406

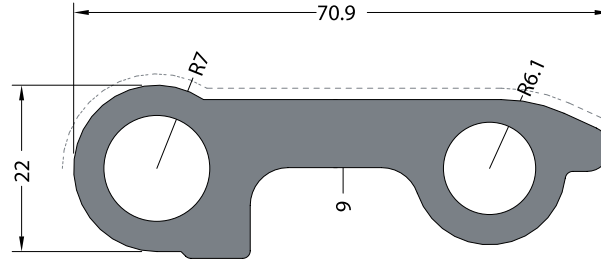

CODE / KOD **THEORETICAL WEIGHT kg/m**
955 *TEORİK AĞIRLIK kg/m*
2.054

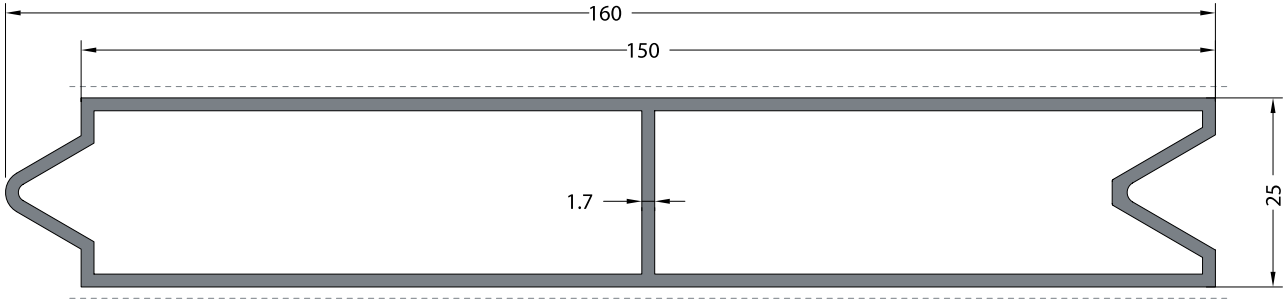

CODE / KOD **THEORETICAL WEIGHT kg/m**
958 *TEORİK AĞIRLIK kg/m*
1.797

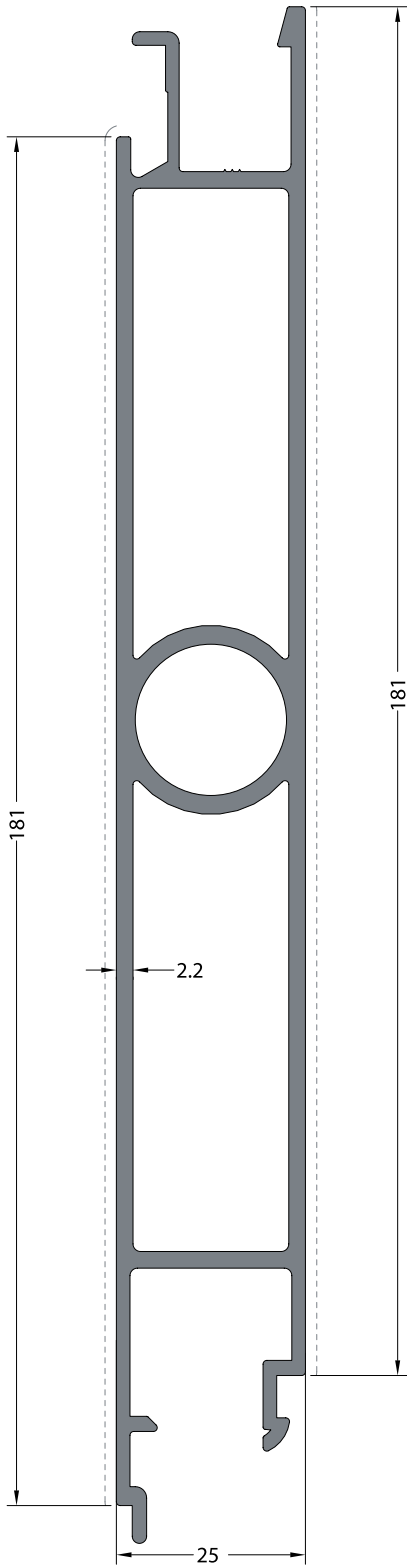

CODE / KOD THEORETICAL WEIGHT kg/m
956 TEORİK AĞIRLIK kg/m
2.957

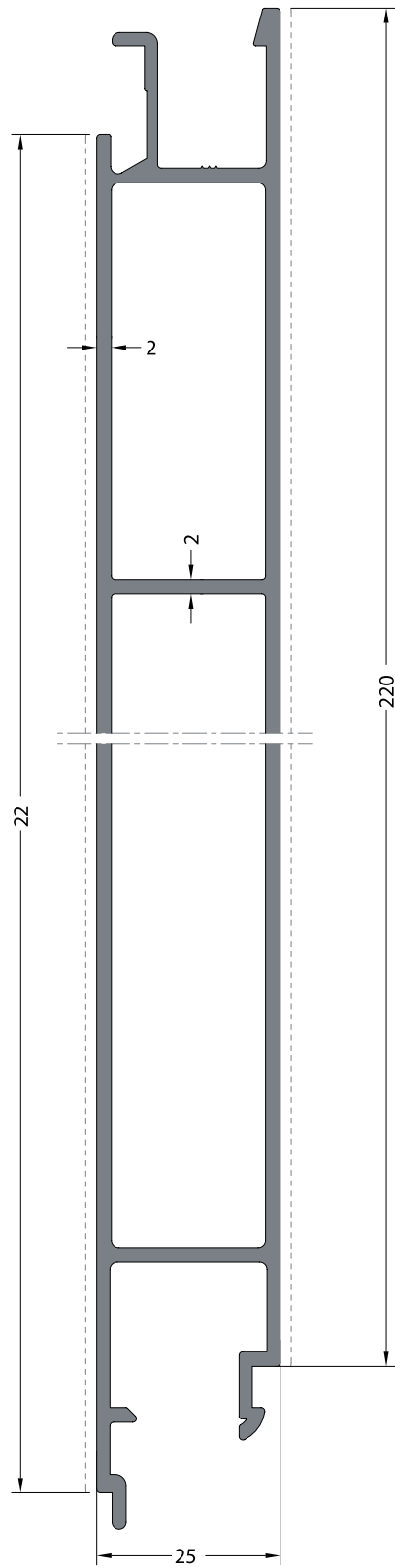

CODE / KOD THEORETICAL WEIGHT kg/m
957 TEORİK AĞIRLIK kg/m
2.950

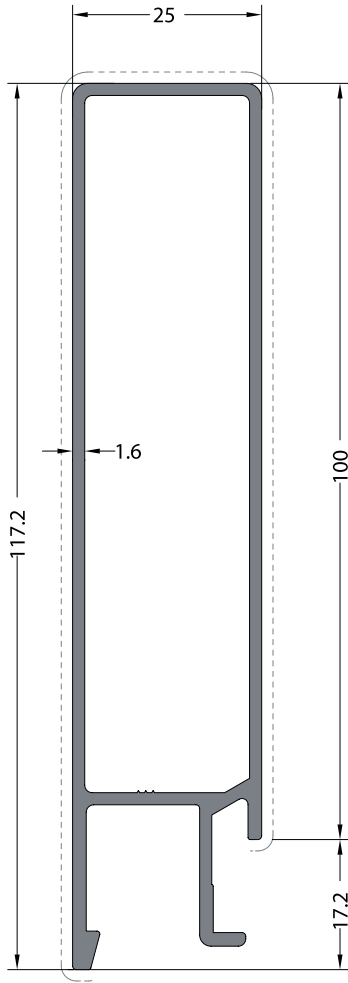

CODE / KOD

959

**THEORETICAL
WEIGHT kg/m**

TEORİK AĞIRLIK kg/m

1.273

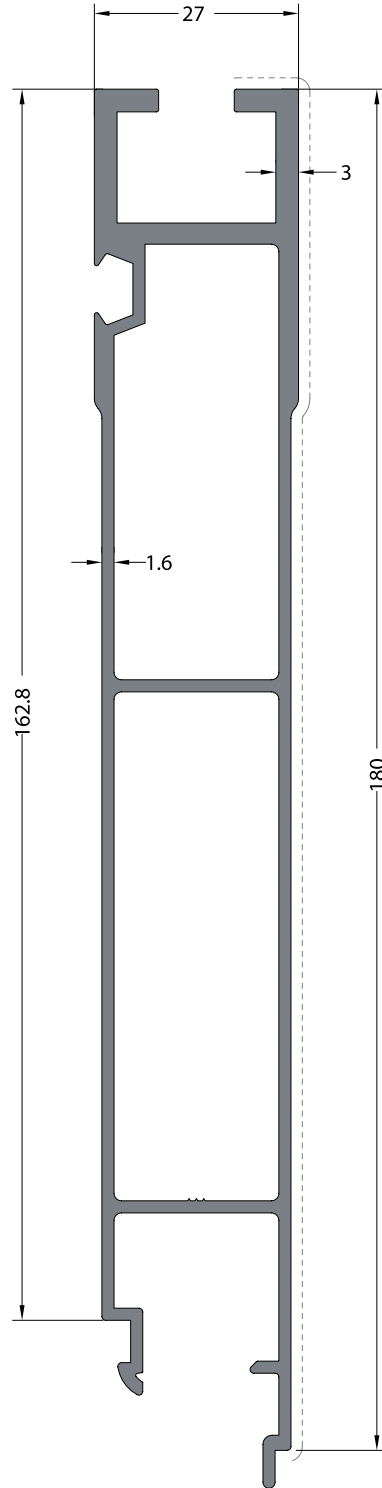

CODE / KOD

960

**THEORETICAL
WEIGHT kg/m**

TEORİK AĞIRLIK kg/m

2.332

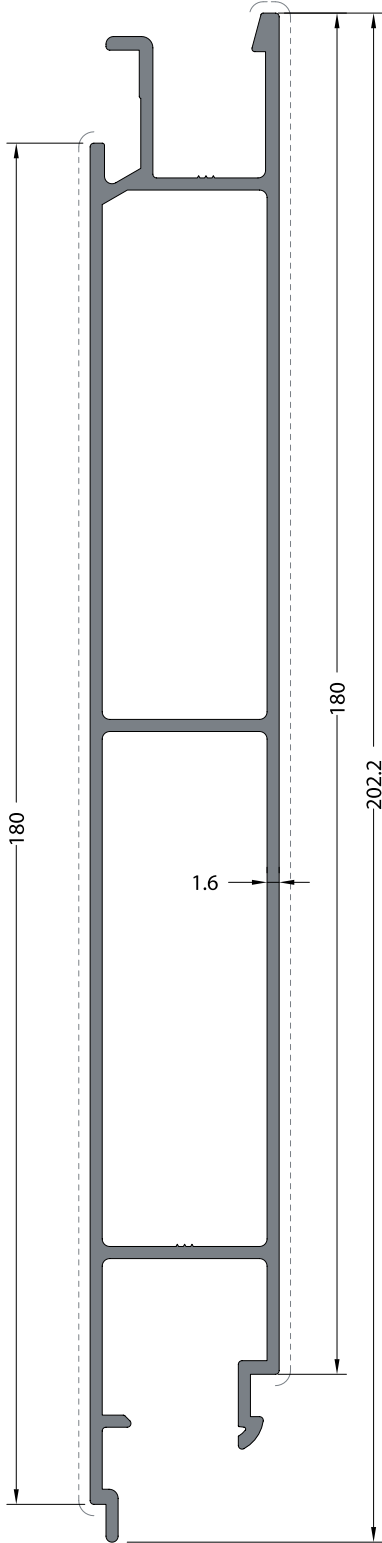

CODE / KOD

961

**THEORETICAL
WEIGHT kg/m**

TEORİK AĞIRLIK kg/m

2.114

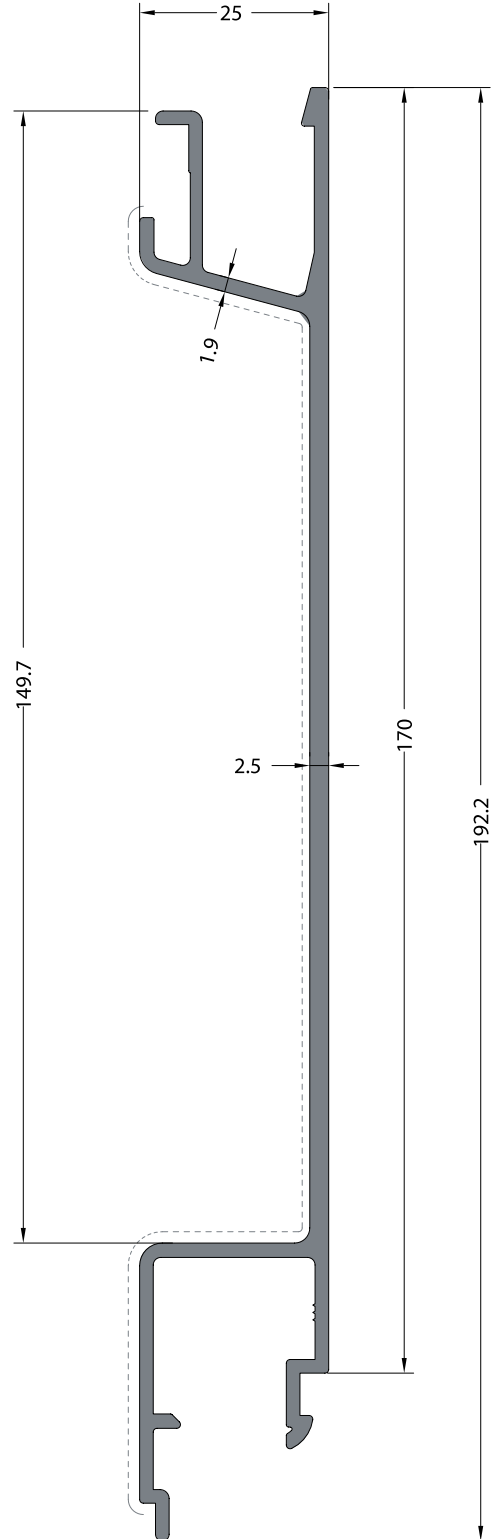

CODE / KOD

962

**THEORETICAL
WEIGHT kg/m**

TEORİK AĞIRLIK kg/m

1.763

tırprofilleri / truckprofiles

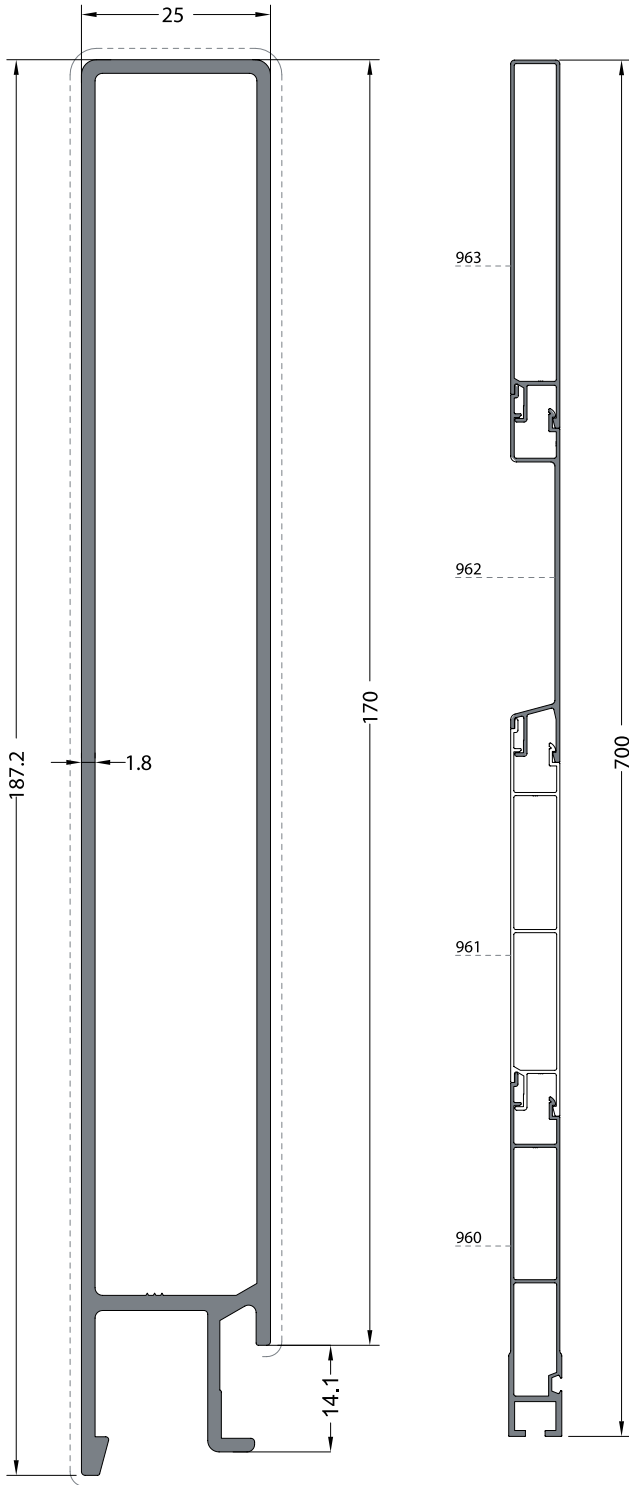

CODE / KOD **THEORETICAL WEIGHT kg/m**
963 *TEORİK AĞIRLIK kg/m*
2.090

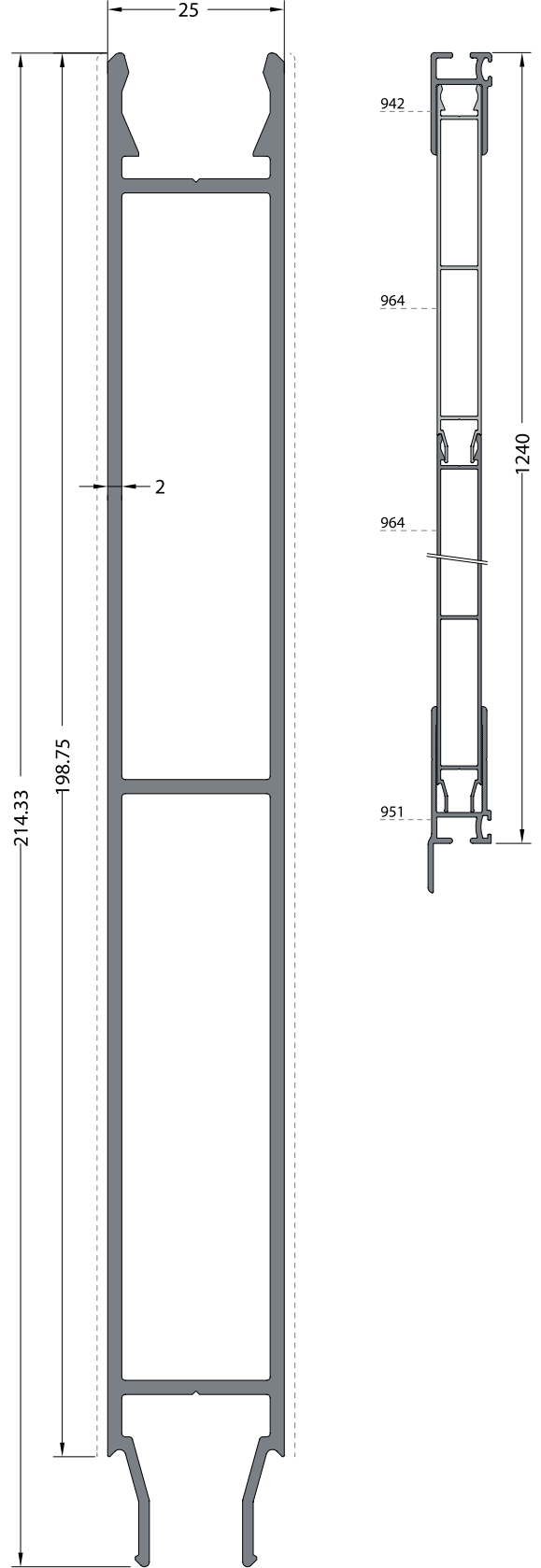

CODE / KOD **THEORETICAL WEIGHT kg/m**
964 *TEORİK AĞIRLIK kg/m*
2.693

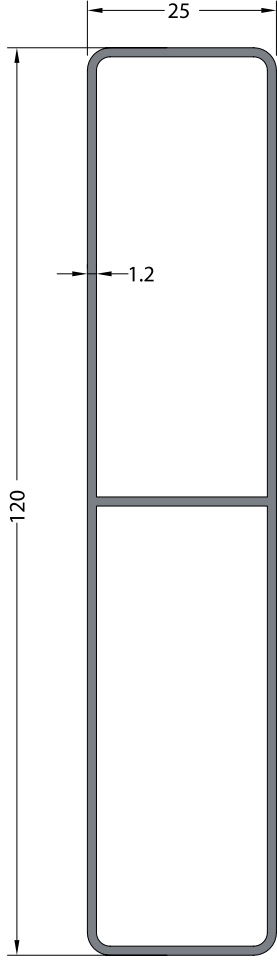

Koruyucu eloksal

CODE / KOD

965

**THEORETICAL
WEIGHT kg/m**

TEORİK AĞIRLIK kg/m

0.988

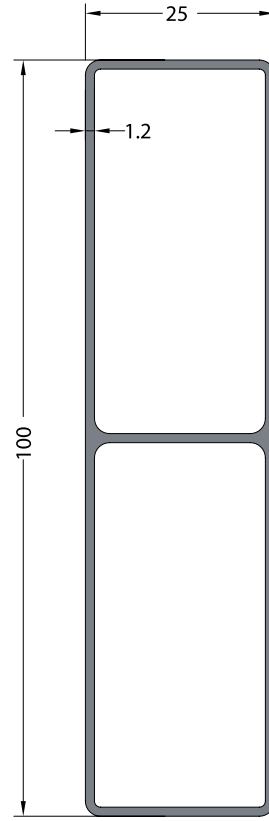

Koruyucu eloksal

CODE / KOD

966

**THEORETICAL
WEIGHT kg/m**

TEORİK AĞIRLIK kg/m

0.872

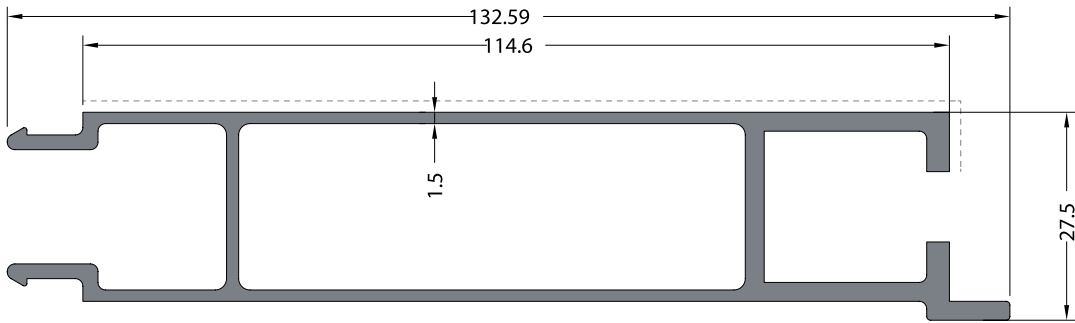
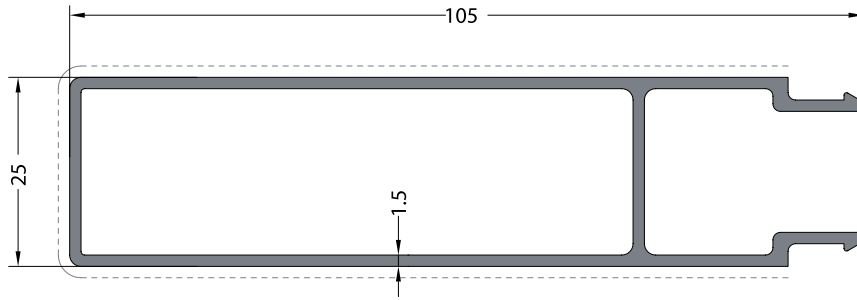
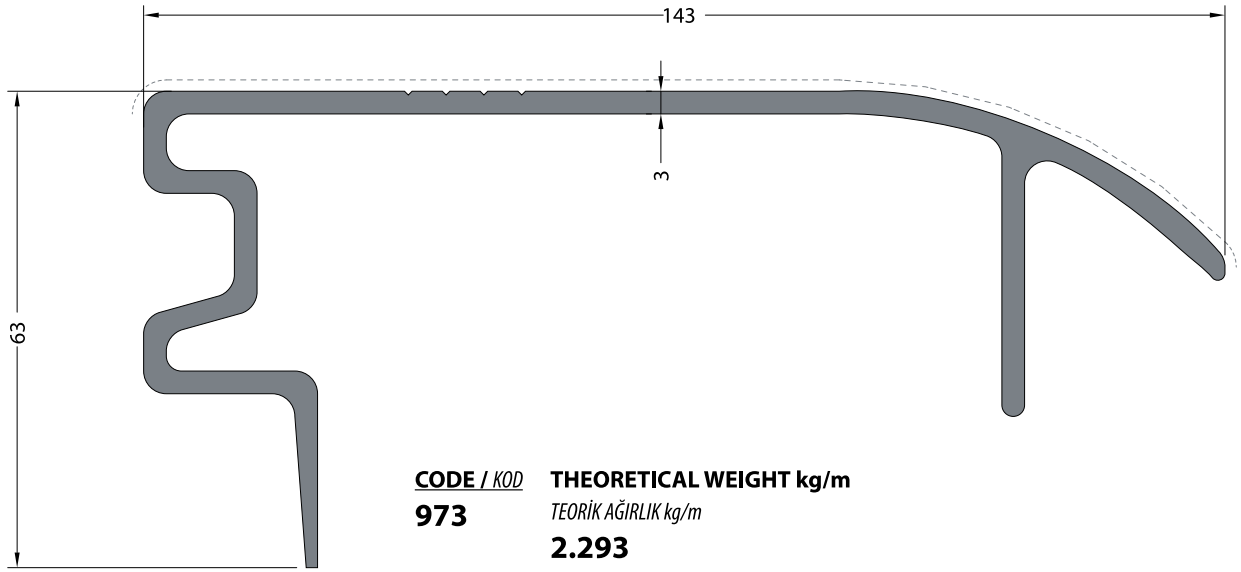

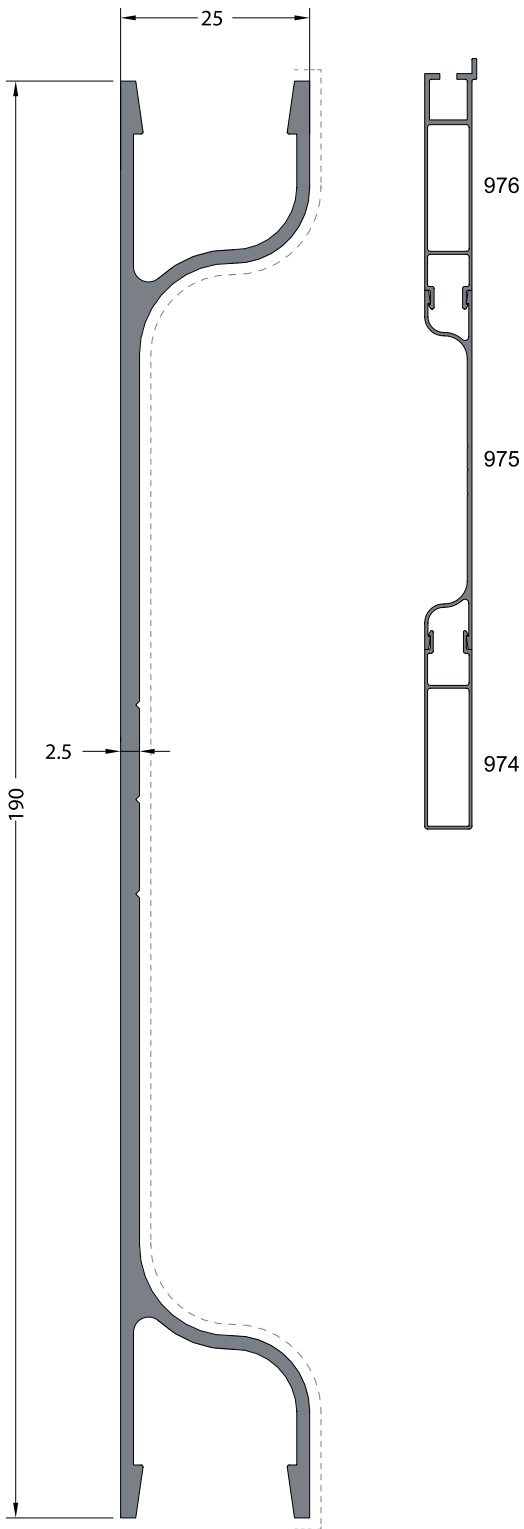

CODE / KOD

975E

THEORETICAL WEIGHT kg/m

TEORİK AĞIRLIK kg/m

1.675

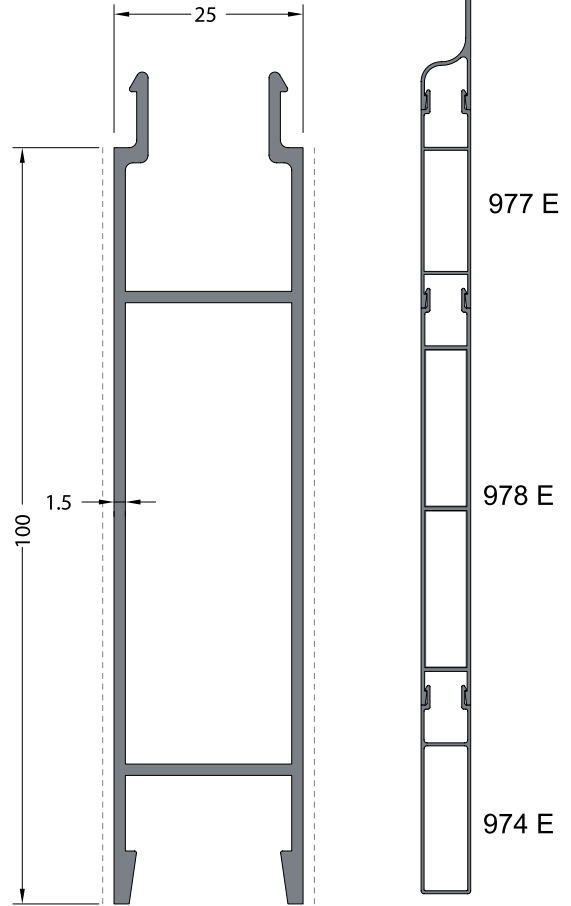

CODE / KOD

977E

THEORETICAL WEIGHT kg/m

TEORİK AĞIRLIK kg/m

1.150

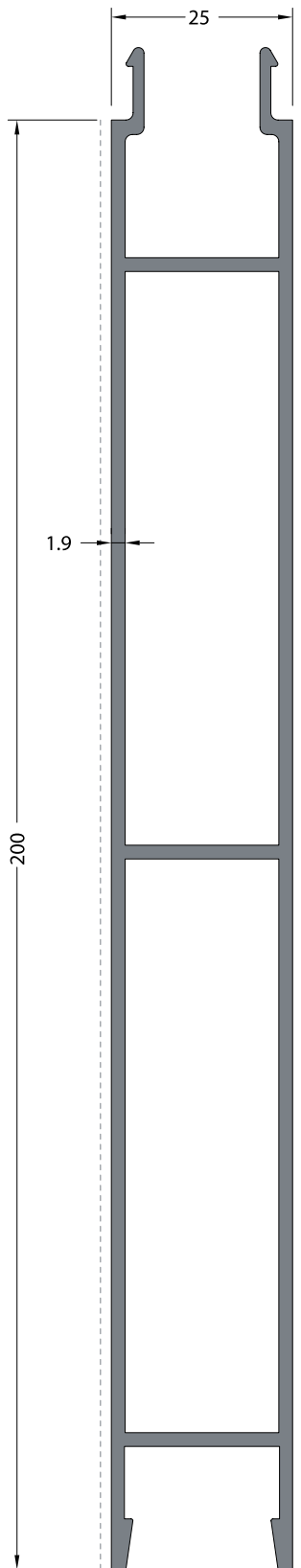

CODE / KOD

978E

THEORETICAL WEIGHT kg/m

TEORİK AĞIRLIK kg/m

2.520

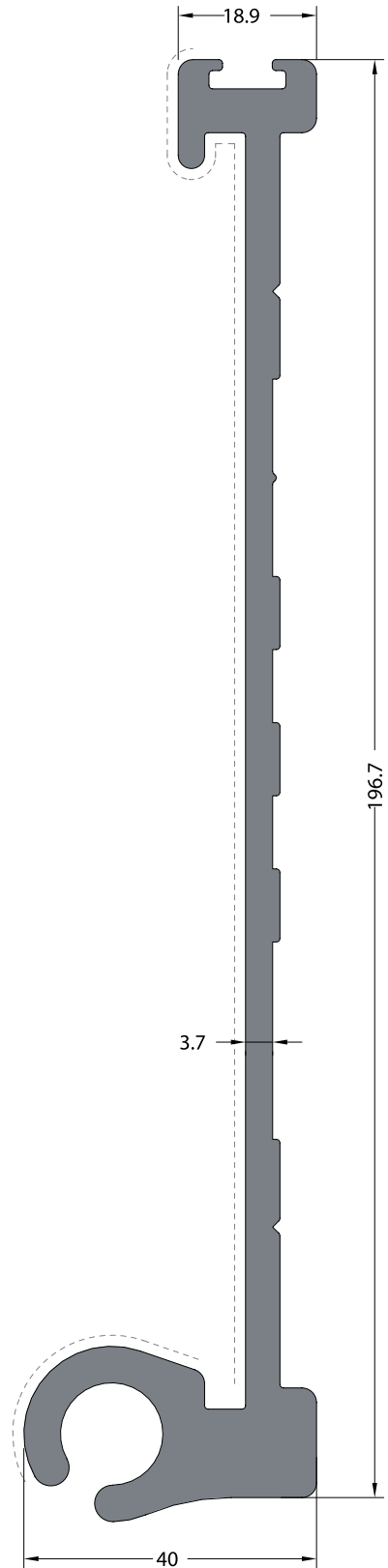
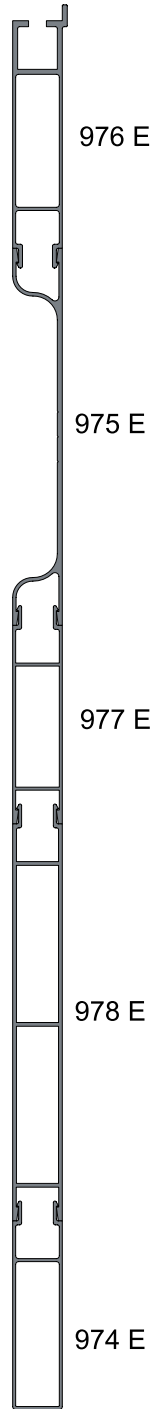

CODE / KOD

988

THEORETICAL WEIGHT kg/m

TEORİK AĞIRLIK kg/m

3.835

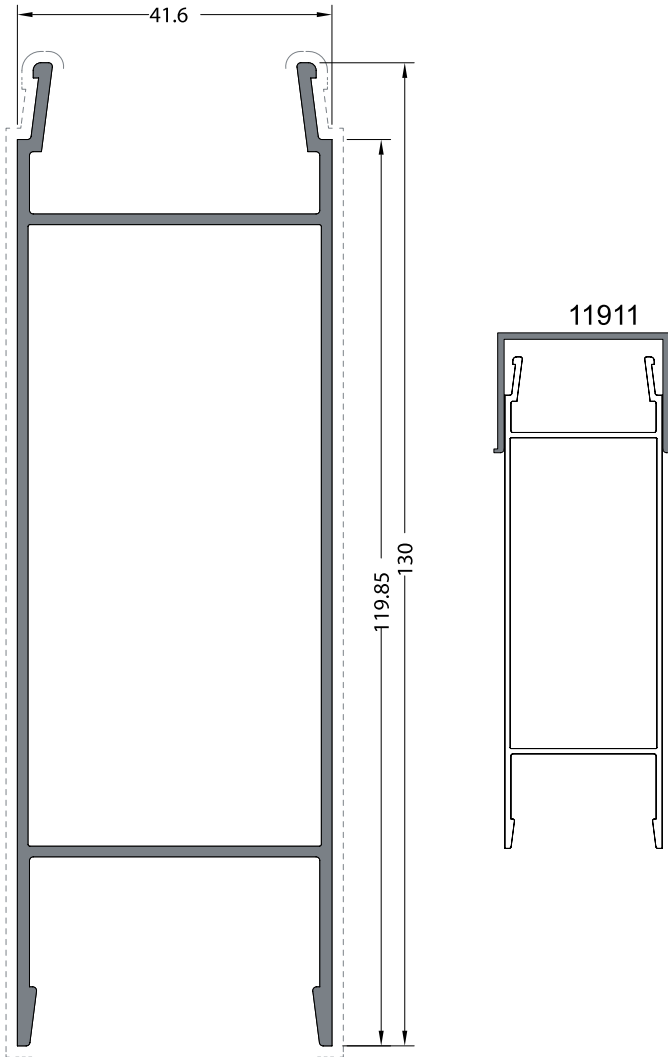

CODE / KOD

994

THEORETICAL WEIGHT kg/m

TEORİK AĞIRLIK kg/m

1.374

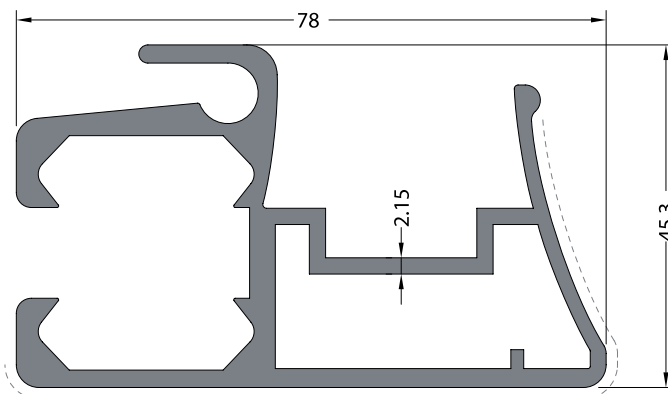

CODE / KOD

989

THEORETICAL WEIGHT kg/m

TEORİK AĞIRLIK kg/m

1.970

tırprofilleri / truckprofiles

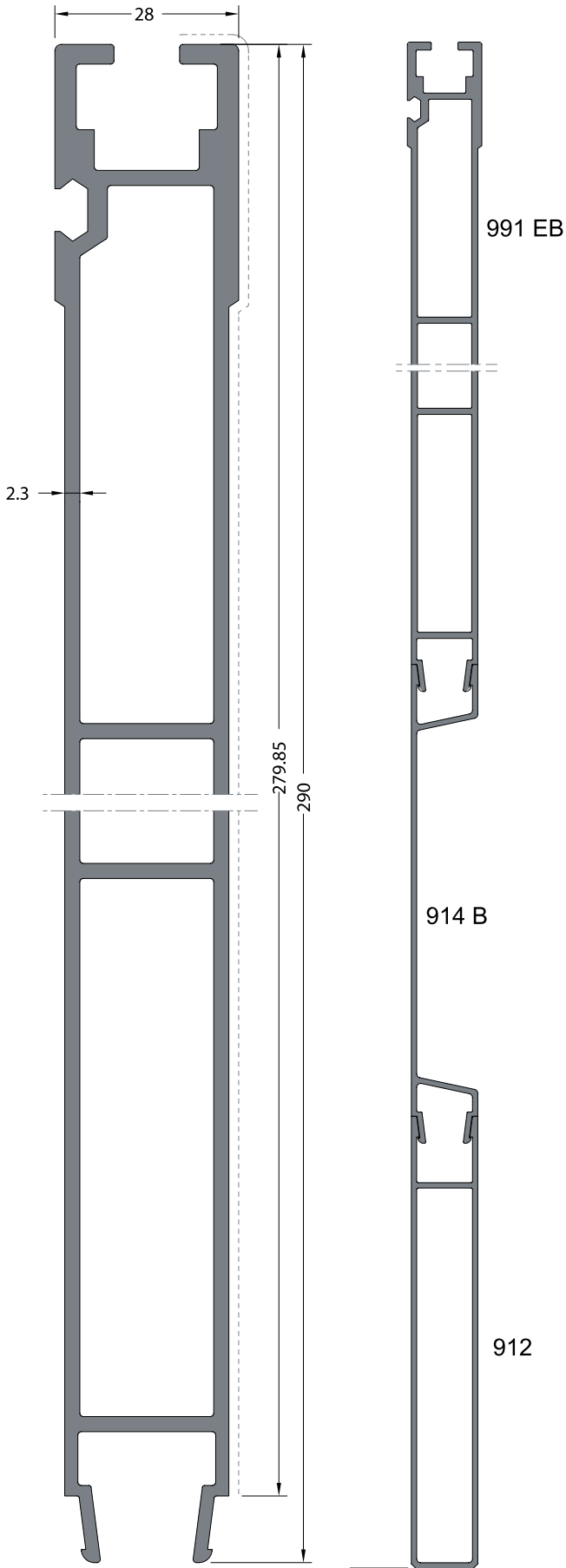

CODE / KOD **THEORETICAL WEIGHT kg/m**
991EB *TEORİK AĞIRLIK kg/m*
4.567

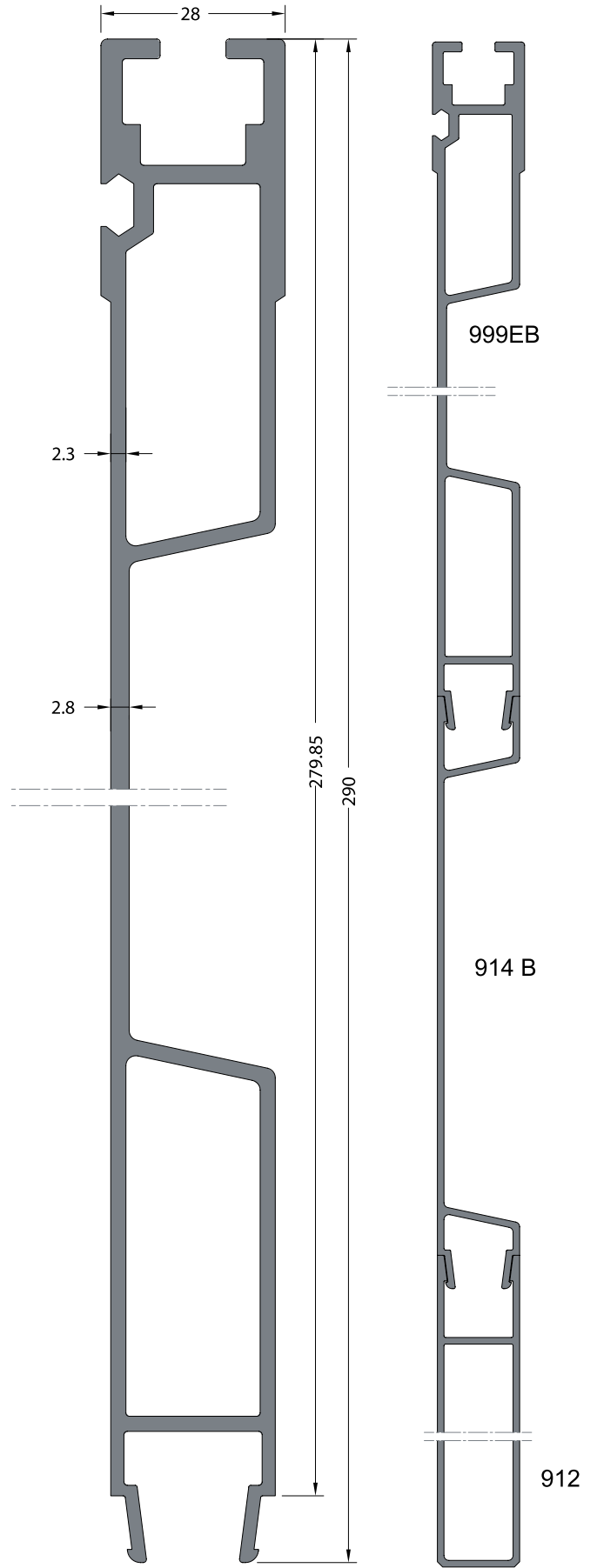

CODE / KOD **THEORETICAL WEIGHT kg/m**
999EB *TEORİK AĞIRLIK kg/m*
3.906

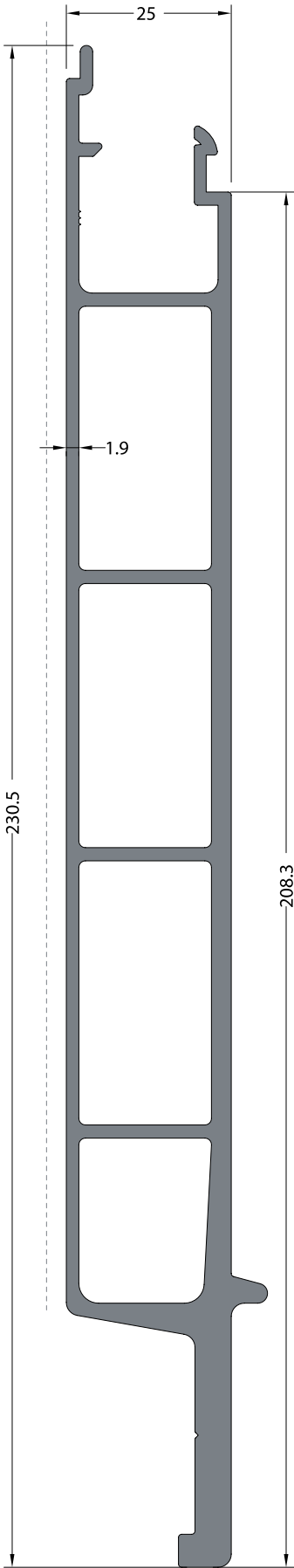

CODE / KOD
928 **THEORETICAL WEIGHT kg/m**
TEORİK AĞIRLIK kg/m
3.764

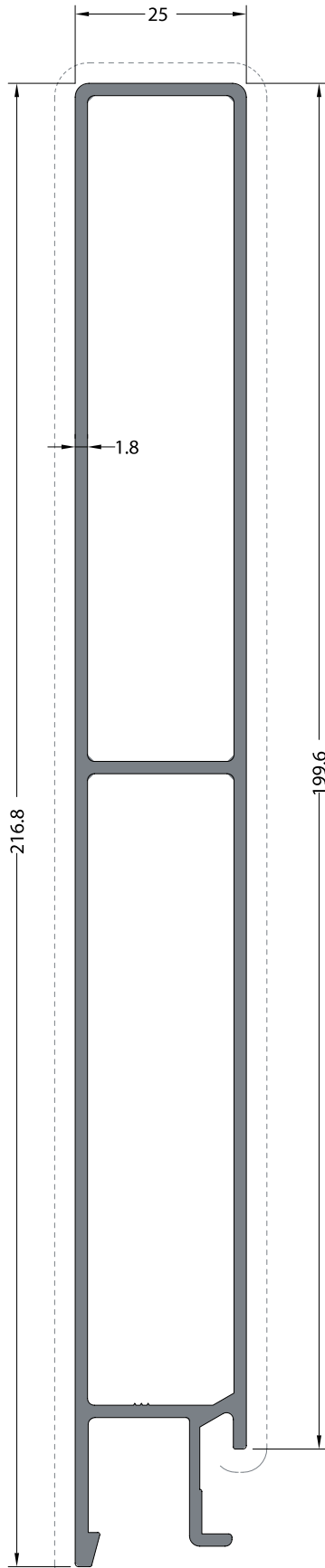

CODE / KOD
929 **THEORETICAL WEIGHT kg/m**
TEORİK AĞIRLIK kg/m
2.478

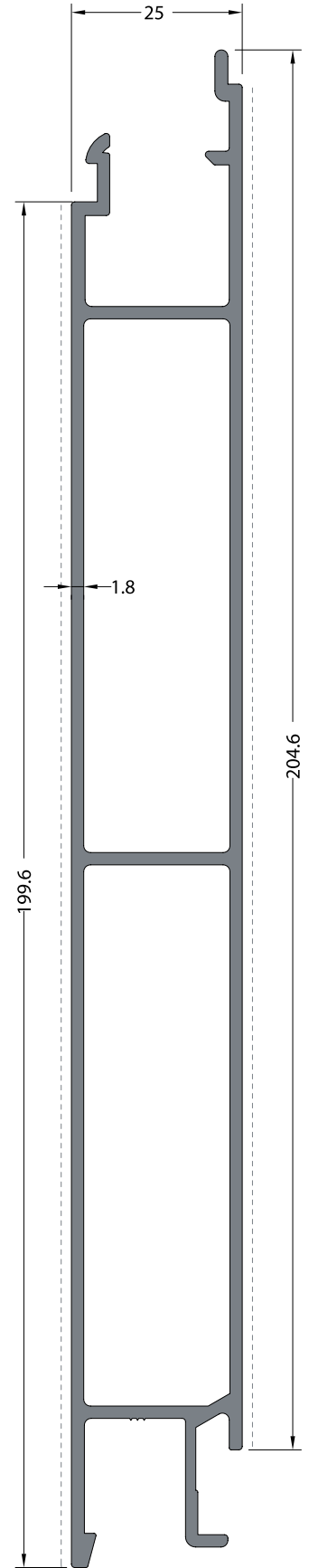

CODE / KOD
930 **THEORETICAL WEIGHT kg/m**
TEORİK AĞIRLIK kg/m
2.548

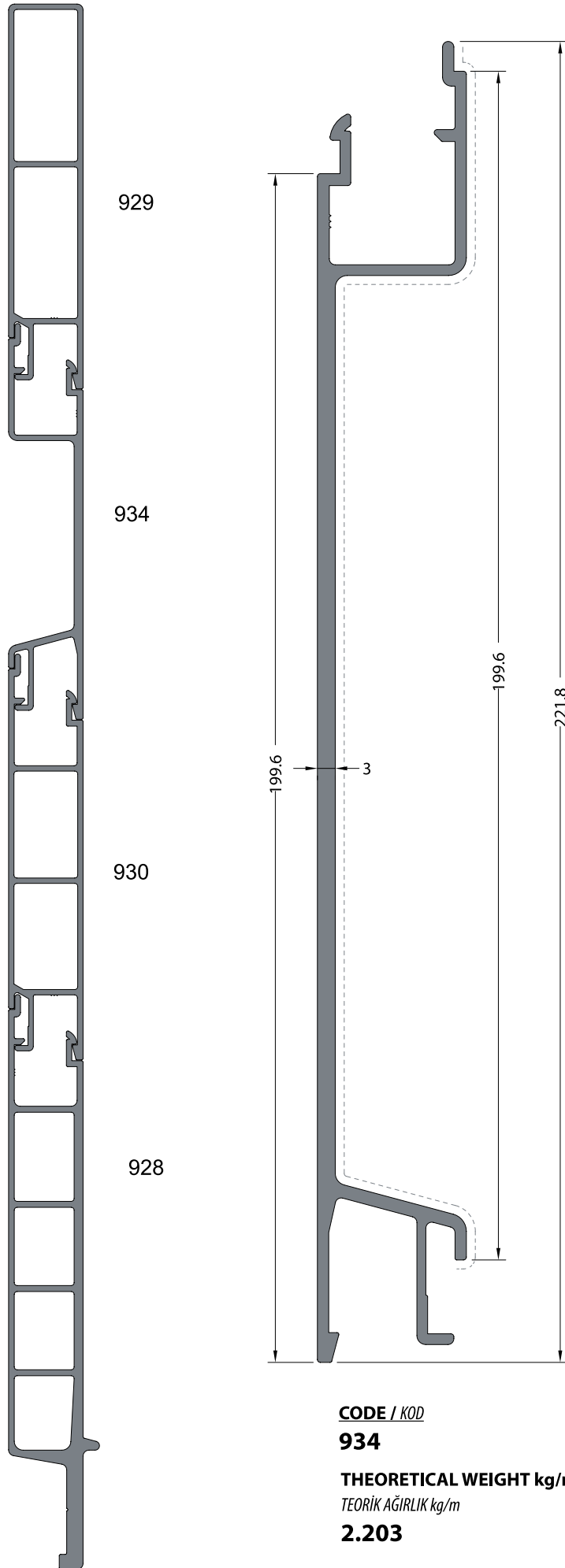

CODE / KOD

934

THEORETICAL WEIGHT kg/m

TEORİK AĞIRLIK kg/m

2.203

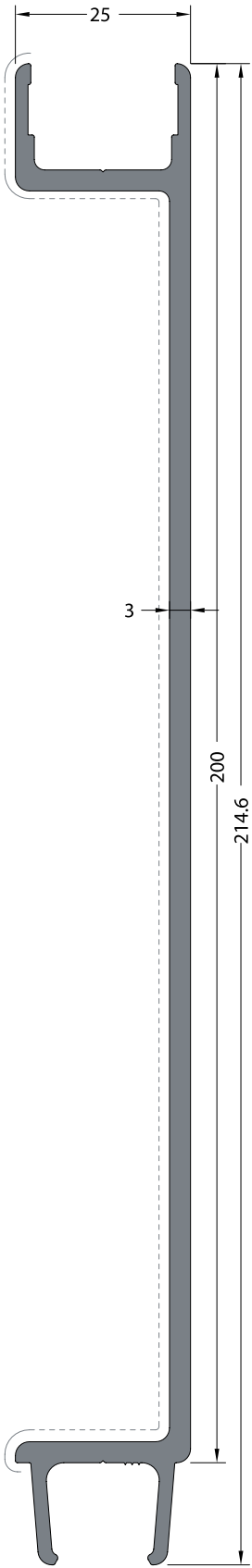

CODE / KOD
931 **THEORETICAL WEIGHT kg/m**
TEORİK AĞIRLIK kg/m
2.202

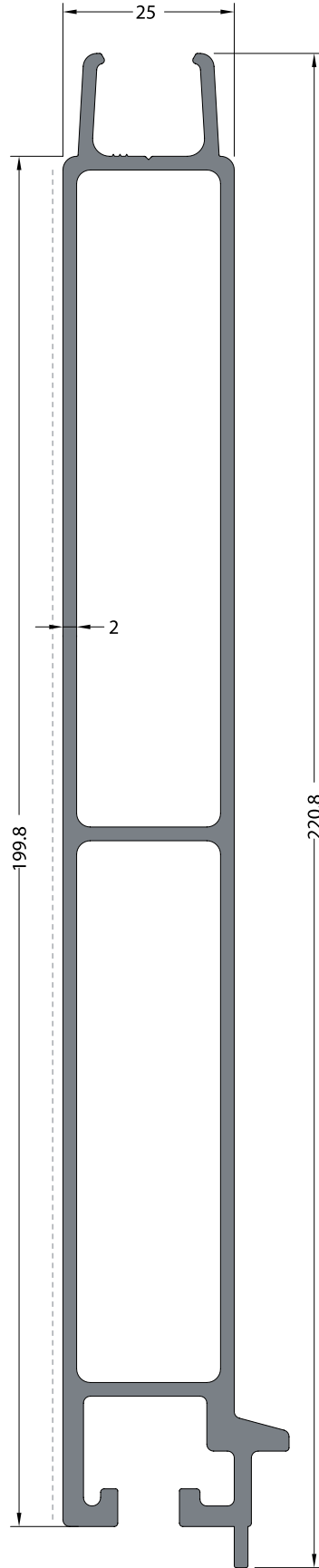

CODE / KOD
932 **THEORETICAL WEIGHT kg/m**
TEORİK AĞIRLIK kg/m
1.033

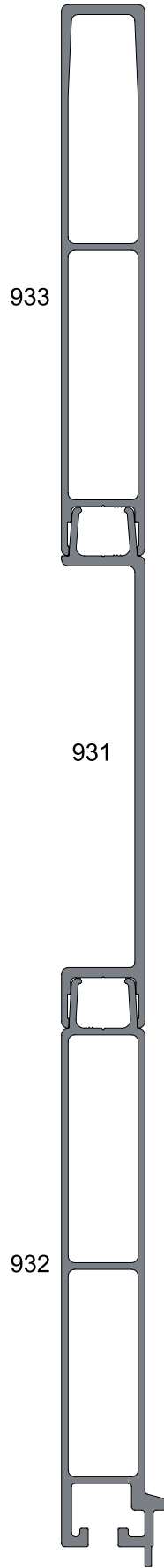

933

931

932

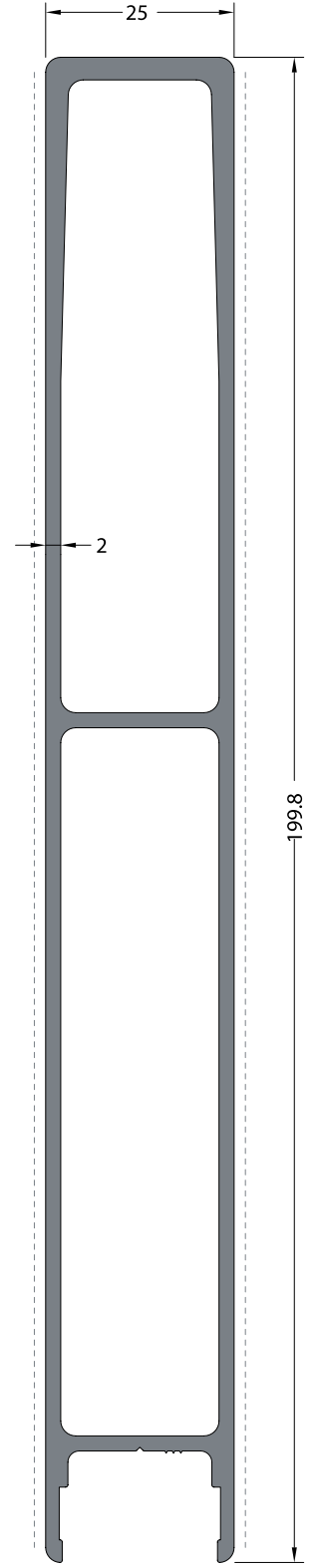

CODE / KOD
933 **THEORETICAL WEIGHT kg/m**
TEORİK AĞIRLIK kg/m
3.069

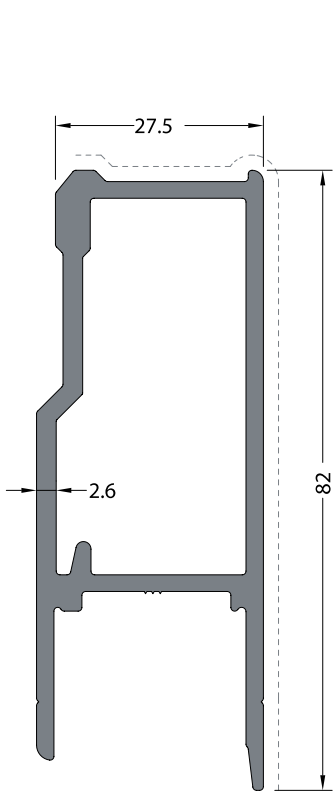

CODE / KOD

935

THEORETICAL WEIGHT kg/m

TEORİK AĞIRLIK kg/m

1.429

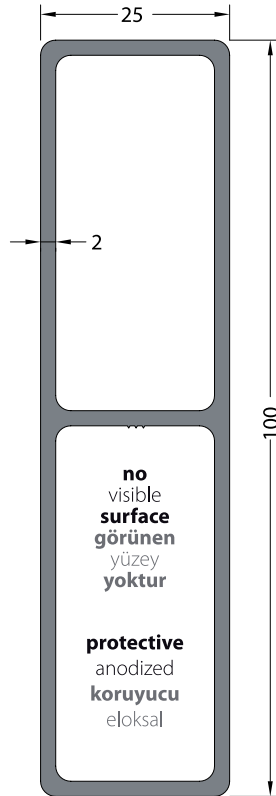

CODE / KOD

936

THEORETICAL WEIGHT kg/m

TEORİK AĞIRLIK kg/m

1.435

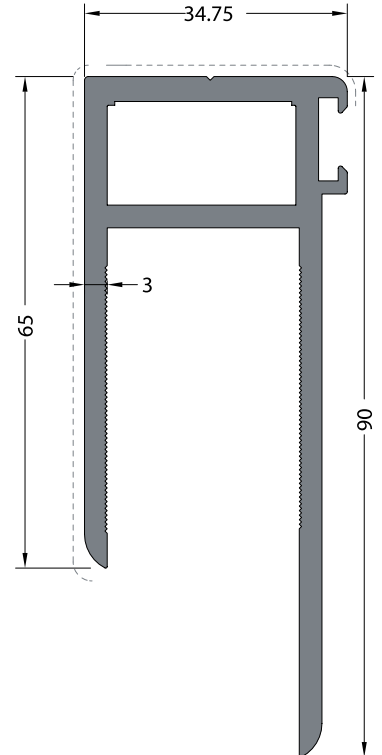

CODE / KOD

982

THEORETICAL WEIGHT kg/m

TEORİK AĞIRLIK kg/m

1.701

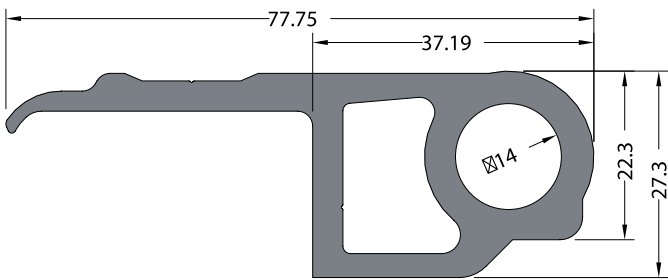

no visible surface görünen yüzey yoktur

CODE / KOD

985

THEORETICAL WEIGHT kg/m

TEORİK AĞIRLIK kg/m

1.769

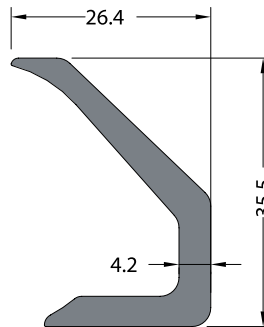

no visible surface görünen yüzey yoktur

CODE / KOD

986

THEORETICAL WEIGHT kg/m

TEORİK AĞIRLIK kg/m

0.671

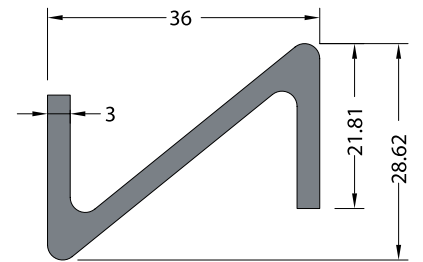

no visible surface görünen yüzey yoktur

CODE / KOD

987

THEORETICAL WEIGHT kg/m

TEORİK AĞIRLIK kg/m

0.684

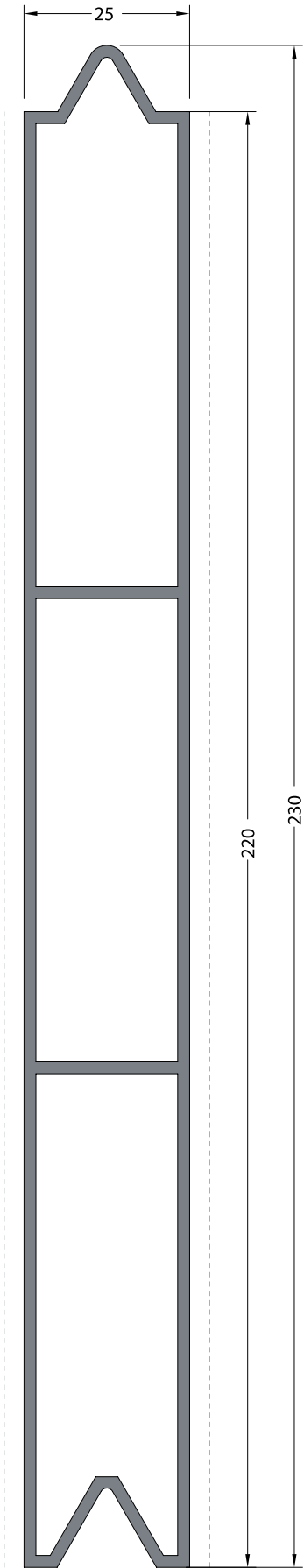

CODE / KOD THEORETICAL WEIGHT kg/m
990 TEORİK AĞIRLIK kg/m
2.685

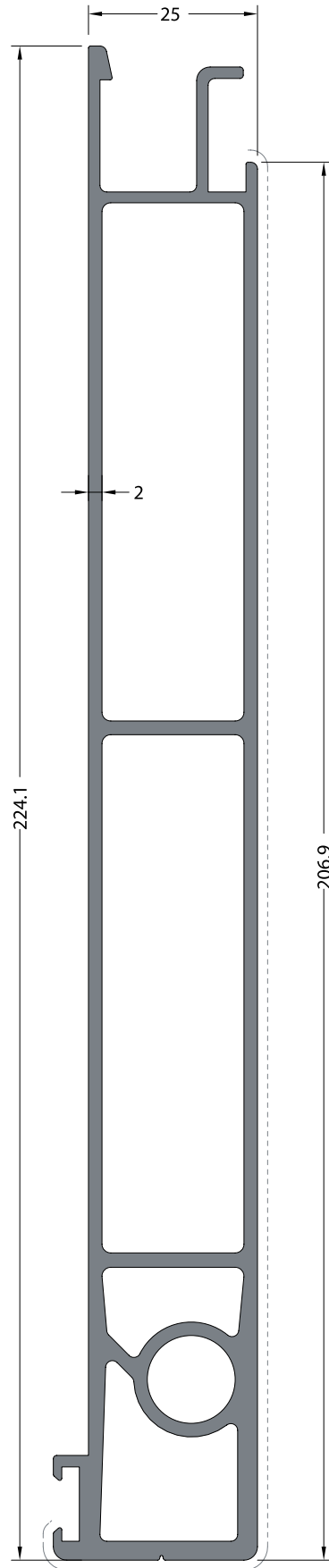

CODE / KOD THEORETICAL WEIGHT kg/m
968 TEORİK AĞIRLIK kg/m
3.427

969

968

tırprofilleri / truckprofiles

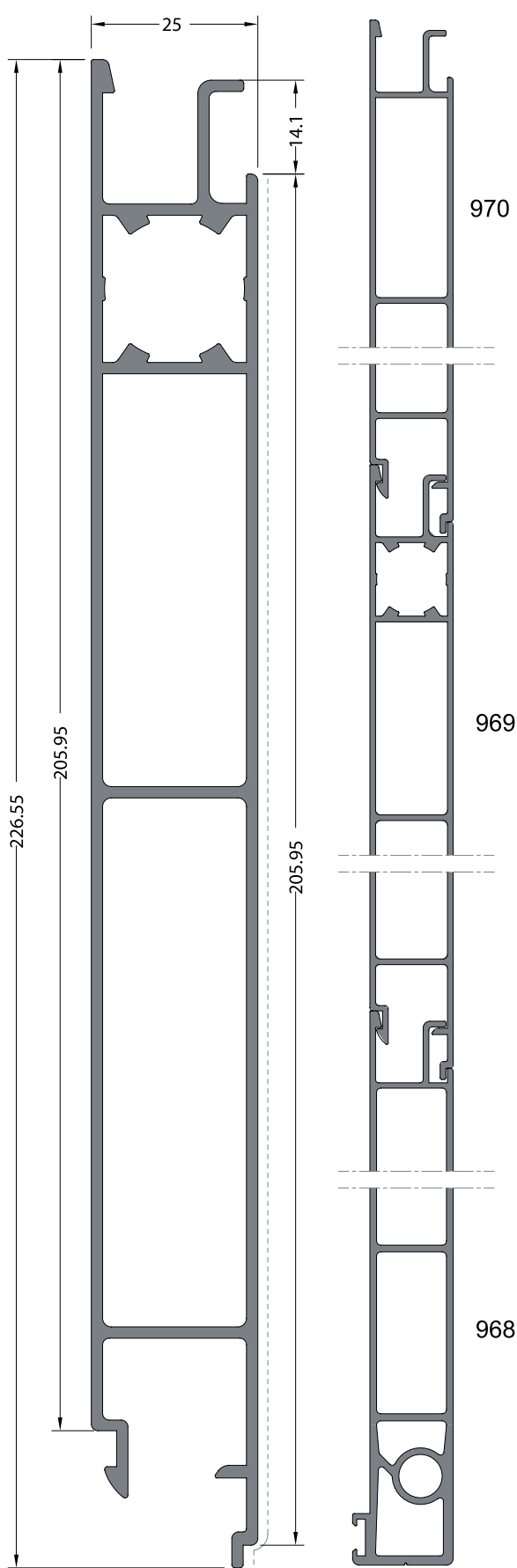

CODE / KOD THEORETICAL WEIGHT kg/m
969 TEORİK AĞIRLIK kg/m
2.653

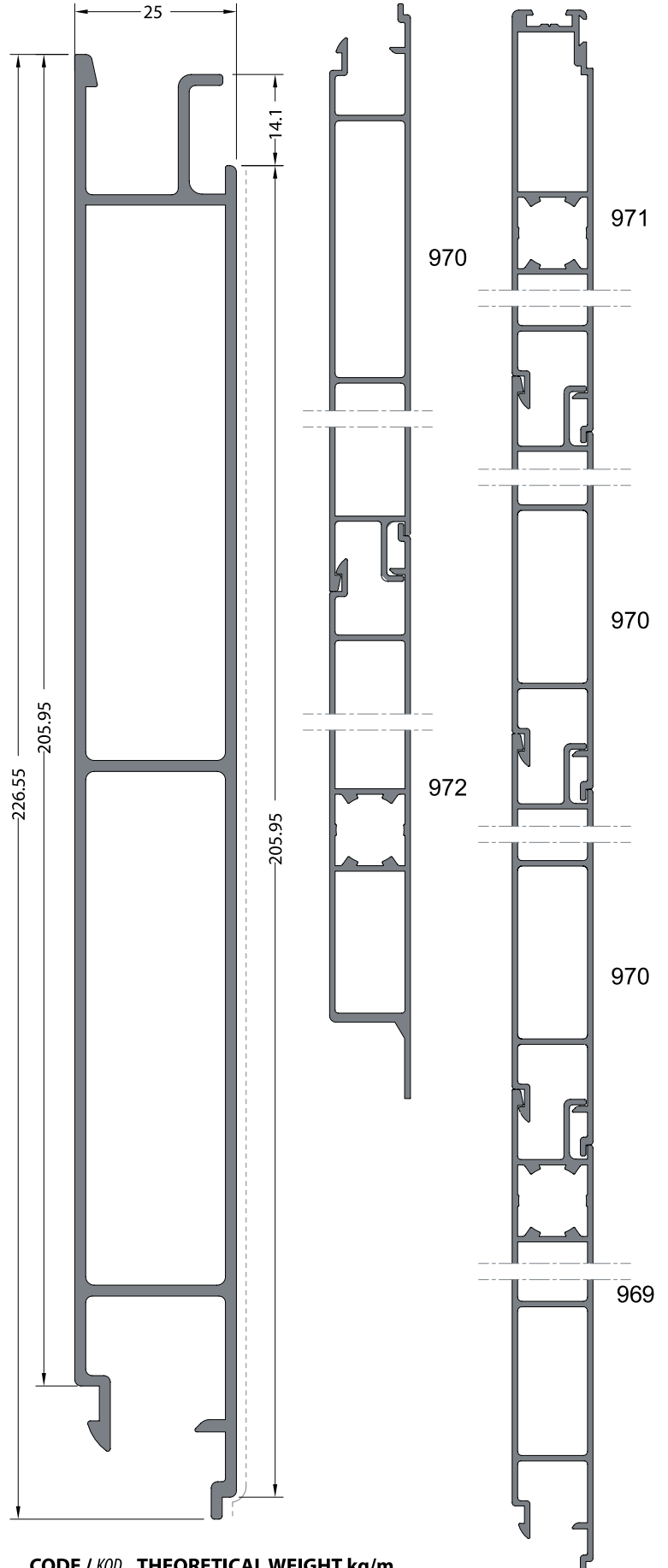

CODE / KOD THEORETICAL WEIGHT kg/m
970 TEORİK AĞIRLIK kg/m
2.449

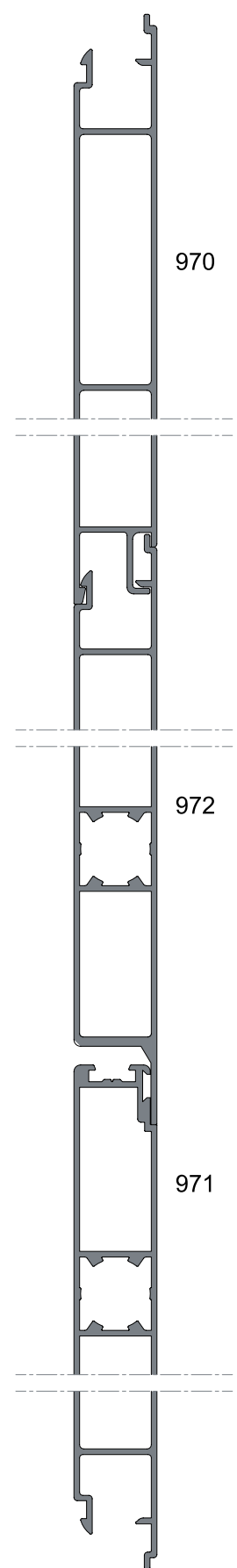
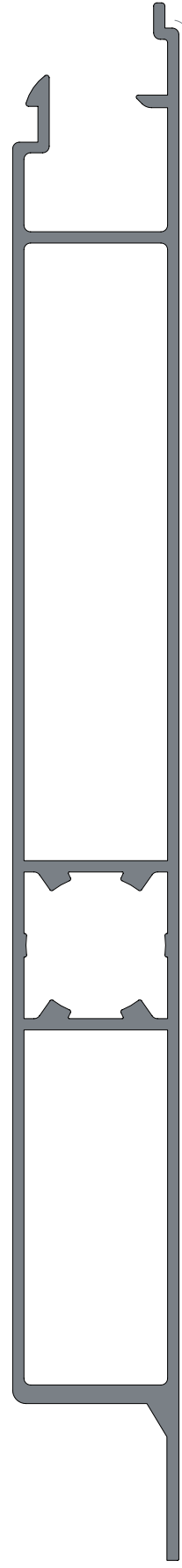
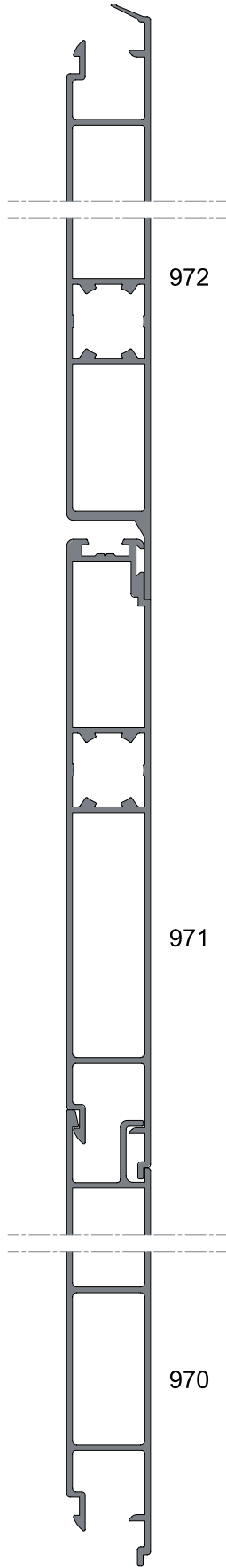

CODE / KOD THEORETICAL WEIGHT kg/m
971 TEORİK AĞIRLIK kg/m
2.561

CODE / KOD THEORETICAL WEIGHT kg/m
972 TEORİK AĞIRLIK kg/m
2.650

Produced by 

KURTOĞLU BAKIR KURŞUN SAN. A.Ş.

Hacıseremet Mevkii, Tem Çorlu Çıkışı Velimeşe 59880 Pk 323 Tekirdağ / TÜRKİYE

T: +90 282 684 70 00

F: +90 282 684 70 01

www.kurtogluas.com

kurtoglu@kurtogluas.com

 **Lorenzoline**[®]
aluminium profile system